

BIRLA CENTRAL LIBRARY
PILANI [RAJASTHAN]

Class No. 621.384

Book No. C473 W

Accession No. 33529

WIRELESS SERVICING MANUAL

By

W. T. Cocking
M.I.E.E

MEMBER OF "WIRELESS WORLD" TECHNICAL STAFF

Illustrated with 130 Diagrams and 22 Photographs

SEVENTH EDITION

(Revised)



Published for

"Wireless World"

by

ILIFFE & SONS LTD

LONDON, BIRMINGHAM, COVENTRY, MANCHESTER AND GLASGOW

Published for "Wireless World" by Iliffe and Sons, Ltd., Dorset House,
Stamford Street, London, S.E.1.

<i>First Published</i>	May, 1936
<i>Second Edition</i>	December, 1936
<i>Third Edition</i>	1937
<i>Fourth Edition</i>	1938
<i>Fifth Edition</i>	1940
<i>Sixth Edition</i>	May, 1941
<i>Second Impression</i>	August, 1941
<i>Third Impression</i>	January, 1942
<i>Fourth Impression</i>	June, 1942
<i>Fifth Impression</i>	February, 1943
<i>Sixth Impression</i>	August, 1943
<i>Seventh Impression</i>	January, 1944
<i>Eighth Impression</i>	December, 1944
<i>Seventh Edition</i>	January, 1946
<i>Second Impression (Revised)</i>	October, 1946
<i>Third Impression</i>	1948

This book is produced in complete conformity
with the authorized economy standards

Made and printed in Great Britain by The Chapel
River Press, Andover, Hants
[Bks. 228/3.48]

CONTENTS

CHAPTER	PAGE
PREFACE	vii
1 TESTING EQUIPMENT	1
2 CURRENT AND VOLTAGE TESTING	9
3 THE INTERPRETATION OF METER READINGS	16
4 VALVES	25
5 TRACING MAINS HUM	29
6 MOTOR-BOATING	47
7 INSTABILITY IN R.F. AND I.F. STAGES	55
8 FREQUENCY AND AMPLITUDE DISTORTION	65
9 BACKGROUND NOISE AND LOCAL INTERFERENCE	81
10 THE ADJUSTMENT OF GANGING—STRAIGHT SETS	91
11 THE ADJUSTMENT OF GANGING—SUPERHETERODYNE I.F. AMPLIFIERS	104
12 THE ADJUSTMENT OF GANGING—SUPERHETERODYNE SIGNAL-FREQUENCY CIRCUITS	115
13 TRACING THE CAUSE OF WHISTLES	129
14 SUPERHETERODYNE WHISTLES	136
15 FREQUENCY-CHANGERS	148
16 AUTOMATIC VOLUME CONTROL SYSTEMS	169
17 SHORT-WAVE RECEIVERS	180
18 SHORT-WAVE CONVERTERS	193
19 THE LOUD SPEAKER	199
20 EXTENSION LOUD SPEAKERS	205
21 THE AERIAL-EARTH SYSTEM	209
22 AUTOMATIC FREQUENCY CONTROL	217
23 PUSH-PULL AMPLIFIERS	228
24 MISCELLANEOUS DEFECTS AND ADJUSTMENTS	244
25 NEGATIVE FEED-BACK	250
26 TELEVISION RECEIVERS	257
27 THE USE OF CATHODE-RAY TEST GEAR	270
APPENDIX	
I COMMON CIRCUIT CONSTANTS	277
STANDARD SYMBOLS	279
USEFUL FORMULÆ	280
SUPERHETERODYNE GANGING	282
SHORT-WAVE AERIALS AND FEEDERS	285
COPPER WIRE TABLES	286
II COLOUR CODES	288
III CAPACITY AND RESISTANCE BRIDGE	292
IV VALVE TESTING BRIDGE	301
V VALVE DATA	309
INDEX	324

LIST OF HALF-TONE ILLUSTRATIONS

	PAGE
AVOMETER, MODEL 7, AND D.C. AVOMINOR	2
MUIRHEAD PRECISION RESISTORS AND CAPACITORS	4
SANGAMO-WESTON ANALYSER	6
<i>Wireless World</i> CAPACITY AND RESISTANCE BRIDGE	7
FERRANTI A.C. TEST SET	15
TAYLOR VALVE TESTER	27
AVO VALVE CHARACTERISTIC METER	28
BRITISH PHYSICAL LABORATORIES TEST SET	54
BELLING-LEE INTERFERENCE SUPPRESSOR	86
TAYLOR SIGNAL GENERATOR	103
BRITISH PHYSICAL LABORATORIES' SIGNAL GENERATOR	113
AVO ALL-WAVE OSCILLATOR	113
ADVANCE COMPONENTS ATTENUATOR	114
LABGEAR C.R. TUBE VIEWING UNIT	128
TAYLOR TEST METER	135
ULTRA-SHORT-WAVE CONVERTER	194
HUNTS CAPACITANCE AND RESISTANCE ANALYSER	269
<i>Wireless World</i> CAPACITY AND RESISTANCE BRIDGE DETAILS	293, 294, 299
<i>Wireless World</i> VALVE TESTING BRIDGE	302, 305

PREFACE

BROADCASTING has now such a definite place in the daily lives of all sections of the community, and is so greatly relied upon for entertainment and instruction, that it is impossible to contemplate with equanimity any breakdown in the system. A general cessation of broadcasting is fortunately an event of extreme improbability, but a breakdown in a receiver is by no means uncommon and to its owner it is just as disastrous.

The repairing of receiving equipment has consequently become an important section of the wireless industry. The growing standard of performance which is demanded of receivers, and their resulting complexity, necessitate a higher degree of skill on the part of the repairer than ever before, and a degree of skill which will certainly not grow less with the passage of time. Radio Servicing is thus becoming a highly-specialized profession, and the days of the self-styled "experts" with no real knowledge of radio technique are for ever gone.

The location of a defect in a commercially-produced receiver, the initial adjustments of a home-constructed set, and the testing of experimental apparatus all call for the application of service principles. Familiarity with these principles is not alone sufficient, however, and the proper testing gear is also necessary, together with an adequate understanding of wireless phenomena. Speed and certainty in the diagnosis and treatment of receiver ailments come only with experience. Methods can be taught, however, and to approach a problem correctly is half way to the solution.

The immediate concern of this book is with purely servicing problems—with the location and cure of the hundred and one defects which can develop in a receiver and its associated equipment. The choice of suitable testing gear is briefly discussed, however, for this is a matter of considerable importance upon which it is not always easy to obtain unbiased information. No attempt has been made to treat wireless theory or to explain the mode of operation, save in one or two isolated cases where the circuit is so new that an adequate description is unlikely to be found in any standard textbook.

Those who lack the necessary understanding of basic principles are recommended to acquire it from a good textbook, and even with the most elementary knowledge of mathematics it is possible to gain sufficient acquaintance with theory for all

PREFACE

service matters. Although mathematical ability may be essential to the designer, it is not to the service engineer. Excellent as they may be, however, textbooks are not sufficient to enable him to keep up-to-date, for in wireless, invention succeeds invention so rapidly that it is possible to remain *au fait* with current developments only by the regular perusal of one or more reliable technical journals.

In compiling this book, the author's aim has been to describe those methods which he has himself found to be the most suitable for the location of defects. The arrangement of material, however, is one of "symptoms" rather than "defects", since he believes that this makes the book handier for reference; and with this same end in view particular attention has been paid to the index. The appendix contains in tabular form much information commonly required by service engineers, including valve base connections for British, American and Continental valves. Here every endeavour has been made to include obsolete as well as current types, for receivers embodying old types of valves are still met with occasionally and information as to the connections is not always readily available.

W. T. COCKING

*Dorset House,
Stamford Street,
London, S.E.1.*

WIRELESS SERVICING MANUAL

CHAPTER I TESTING EQUIPMENT

RAPID and efficient servicing demands the use of the proper tools. They are neither many nor unduly expensive, but they are essential to all who seek to place their profession on a profitable basis. It is in many cases quite possible for the expert to locate defects in receivers and to repair them satisfactorily with but little apparatus; yet much time is wasted, and time is a very important factor in any organization of servicing on a commercial basis.

The apparatus should be of good quality. Reliability and ruggedness are of the first importance, and a laboratory standard of accuracy is unnecessary. The service man should be able to take D.C. measurements of voltage within ± 5 per cent. from 1 volt to at least 600 volts, and current with the same accuracy from 0.5 mA to 1 ampere; for A.C. work, voltages between 2 volts and 1,000 volts will be encountered, but current measurements are not often required. He must be able to check the values of resistances to within ± 10 per cent. for values between 1 ohm and at least 2 megohms, and the values of condensers between 50 $\mu\mu\text{F}$ and 4 μF . He must have a modulated test oscillator and output meter, a set of valve adaptors and such tools as pliers, screwdrivers, wirecutters, soldering-iron, and so on.

Although a range of different voltmeters and milliammeters is extremely useful and enables different measurements to be made simultaneously, a multi-range A.C. and D.C. voltmeter and milliammeter, which may also be combined with an ohmmeter, is just as useful for most service work. Instruments of this nature are available commercially at reasonable prices, but when selecting one care should be taken to see that the resistance of the voltmeter is high. It is, however, quite easy to construct such an instrument around a single low-range milliammeter. If this course be adopted, a moving-coil milliammeter of good quality should be obtained, and it will pay to buy as good an instrument as one can afford. The diameter of the scale should not be less than some $2\frac{1}{2}$ in., and a meter having a full-scale deflection for a current of 1 mA is best.

The connection of a suitable resistance in series with such a meter will convert it into a voltmeter, and since the meter

WIRELESS SERVICING MANUAL

resistance is negligible compared with the added resistance for all ranges normally required, the necessary value of added resistance in ohms equals the voltage required for full-scale deflection multiplied by 1,000.

The connections for a three-range voltmeter with resistance values are shown in Fig. 2 : such an instrument has ranges of 0-10, 0-100, and 0-1,000 volts with an internal resistance of 1,000 ohms per volt. If accurate resistances are used, no calibration is needed, and it is only necessary to multiply the meter reading by 10 for the 0-10 volts range, by 100 for the 0-100 volts range, and by 1,000 for the 0-1,000 volts range to obtain the correct voltage. For most purposes it will suffice to buy wire-wound resistances accurate within ± 1 per cent., and these can be obtained quite reasonably, for most makers can supply resistances of this accuracy for a small extra charge.

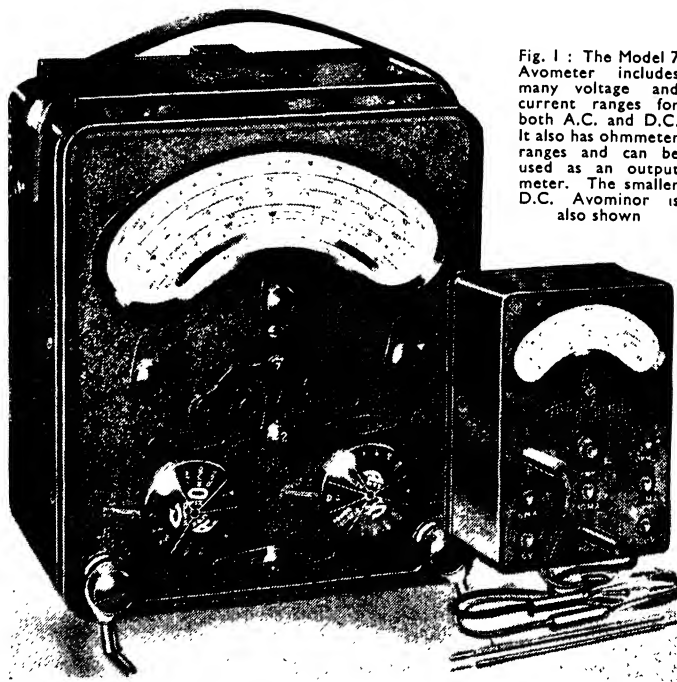

Fig. 1 : The Model 7 Avometer includes many voltage and current ranges for both A.C. and D.C. It also has ohmmeter ranges and can be used as an output meter. The smaller D.C. Avometer is also shown

TESTING EQUIPMENT

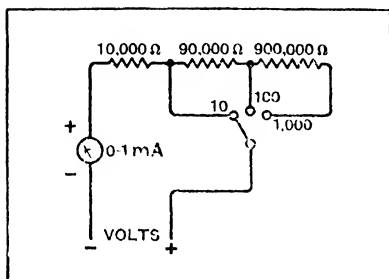

Fig. 2 : This diagram shows the connections of a typical multi-range voltmeter

the meter reads full-scale for a current of 10 mA ; tapping points are then selected so that full-scale deflections for 100 mA and 1,000 mA (1 ampere) are obtained. The total value of the shunt resistance should be one-ninth of the meter resistance. This is usually about 100 ohms, so that the shunt should be about 11 ohms, but as the meter resistance is rarely accurately known, the value of the shunt must be determined experimentally, as also must the tapping points, with the aid of another meter.

The subject of making such gear is not one which can be entered into here, but it may be said that it is quite possible to make an A.C. voltmeter and milliammeter out of the same basic meter by adding a suitable metal rectifier. The whole apparatus can be combined in one case with switches to make the necessary circuit changes and a multi-range D.C. and A.C. voltmeter and milliammeter obtained.

Since the response is usually good up to 10 kc/s it can also be used as an output meter.

A power rating of 1 watt is adequate, and the 900,000 ohms resistance should be made up of several of lower value connected in series.

A multi-range milliammeter can be built with the same basic instrument in several different ways. One of the best is shown in Fig. 3. The meter is shunted by a resistance having a value such that

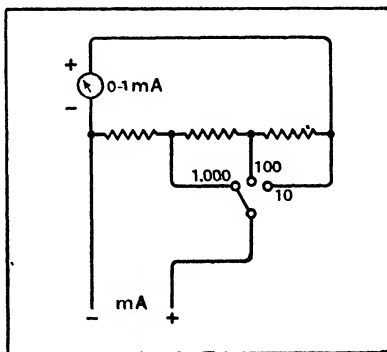

Fig. 3 : One method of obtaining a number of different current ranges is shown here

WIRELESS SERVICING MANUAL

The Ohmmeter

The ohmmeter is equally easy to deal with, for basically it is nothing more than a voltmeter and suitable battery. Suppose, for instance, that the voltmeter (resistance 1,000 ohms per volt) is set on the 10-volts range and a battery of exactly 10 volts is connected in series with one of its leads. Save that it is uncalibrated, the gear is then an ohmmeter. It will read full-scale if the external circuit has zero resistance and read nothing if it has infinite resistance. When the circuit has the same resistance as the meter, 10,000 ohms, the meter will read half-scale.

Calibration for different resistance values is readily obtained either by calculation or by the insertion of known values. In practice, however, ohmmeters are somewhat more complex, but only because means are incorporated for compensating for variations in the battery voltage.

Although the ohmmeter is an exceedingly useful piece of equipment it is rarely very accurate, for even when correction is applied the falling battery voltage introduces some error, and the scale is an awkward one, being very cramped for high resistances. The ohmmeter thus finds its greatest application in continuity testing and in the rough measurement of resistances. For more accurate work a bridge is advisable.

In general testing it is exceedingly important to have means of checking the capacity of condensers, for components having an internal open-circuit or wrongly-marked values are by no means unknown. With an A.C. meter it is possible to devise



Fig. 4: Group of Muirhead precision components. The resistors and capacitors have a 1 per cent. tolerance on value

TESTING EQUIPMENT

a method of measuring capacity which is similar to the ohmmeter for resistance. It is not a very satisfactory method, however, for it necessitates an A.C. supply, which may not always be available, and it is only reasonably accurate with large capacity condensers. The bridge method is far better.

Inexpensive bridges for resistance and capacity measurements are commercially available, and constructional details of a simple bridge are given in Appendix III. This instrument will give direct readings of both resistance and capacity over the wide range of $10 \mu\mu\text{F}$ to $10 \mu\text{F}$ and 10 ohms to 10 megohms. It consists of two parts—the bridge proper and an A.F. oscillator for exciting it. The latter has self-contained batteries and may also be used for modulating an R.F. oscillator when required.

The measurement of inductance is much more difficult. It is rarely required to check A.F. inductances in servicing, but it would undoubtedly be useful to have a method of measuring the inductance of tuning coils. Unfortunately, however, accurate methods are essential for these and measurements are of little value unless they can be relied upon to at least ± 1 per cent. A good inductance bridge is much more expensive than the equipment which will serve for capacity tests and it is hardly portable. For the service shop, where many tests have to be carried out, however, the Baldwin Inductance Bridge can be recommended.

Essential Test Oscillator

Although an inductance bridge may be something of a luxury, a test oscillator is almost essential. It should cover the range of 0.1–25 Mc/s at least and be accurately calibrated, particularly over the band of 420–500 kc/s, within which the intermediate frequencies of most superheterodynes lie. It should be well screened and its output should be adjustable over a wide range—100 μv to 1 v, and the minimum is better 10 μv or less. It should be modulated and arranged so that the modulation can be switched on and off at will. The type of oscillator which is fitted with separate coils is usually to be preferred to that which relies upon harmonics for a wide tuning range.

The test oscillator is used mainly to provide a known signal for ganging purposes, and quite a simple one can be satisfactory. The most important points to look for are the accuracy of the frequency calibration, an adequate range of output, and an absence of reaction of the output control upon frequency. This last point is particularly important and one in which the

WIRELESS SERVICING MANUAL

cheapest oscillators often fail badly. Its importance will be realised when it is remembered that in ganging a set it is usually essential for a whole series of adjustments to be made at a single frequency. As the adjustments are carried out the gain of the set varies, and the output of the test oscillator has to be altered to suit it. Clearly, then, it will not be satisfactory if this alteration of the output changes the frequency.

One must, however, be realistic and recognise that complete freedom from the effect is unlikely to be found in anything but expensive equipment. In practice, it will normally suffice if the frequency does not change by more than 1 part in 1,000 for the whole range of output. For a change in output below 1 mV., the change of frequency should not exceed 1 part in 10,000. Fortunately, in practice, the greatest alteration of



Sangamo - Weston
Analyser, Model
E 772, Type 4

TESTING EQUIPMENT

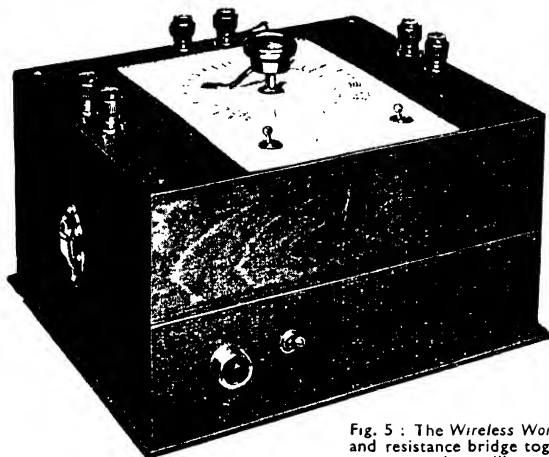

Fig. 5 : The *Wireless World* capacity and resistance bridge together with its oscillator

frequency is usually found for changes of output near the maximum.

For laboratory and experimental work, as distinct from repairing, a standard signal generator is much better than a test oscillator, but is much more expensive. The two instruments are essentially similar and the signal generator is really a highly refined test oscillator. It is much better screened and it contains meters which enable a known depth of modulation to be used and a known R.F. output to be applied to the attenuator. The attenuator is accurately made and gives a known attenuation.

The signal generator, therefore, is essentially a measuring instrument providing a modulated R.F. output of known amplitude, frequency and depth of modulation. The test oscillator gives the same kind of output but neither the R.F. output nor the depth of modulation are known with any degree of accuracy. Of course, there are all grades of both instruments, and a low grade signal generator may be almost indistinguishable from a first-class test oscillator.

For use with the test oscillator an output meter is very desirable, but not essential. It consists basically of an A.C. voltmeter of the rectifier type with a transformer. Some instruments have a tapped transformer so that the meter impedance can be matched to the valve, but a fixed ratio is

WIRELESS SERVICING MANUAL

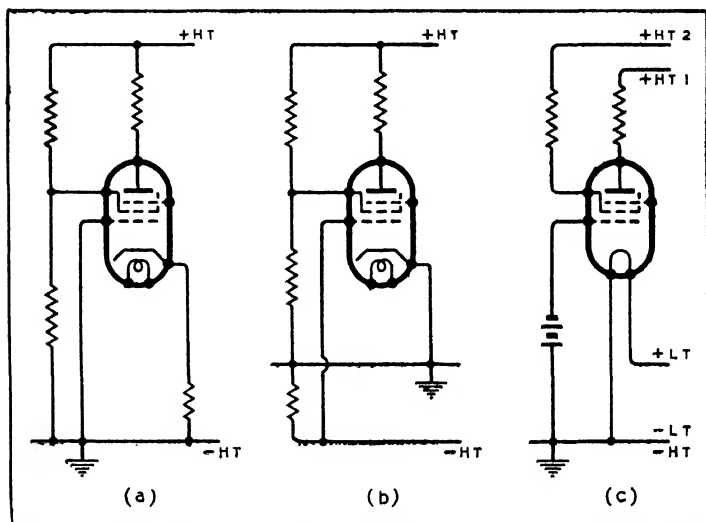

Fig. 6 : The basic voltage supply arrangements are shown in outline, coupling components and by-pass condensers being omitted. At (a) cathode bias is used, while at (b) a resistance in the negative H.T. lead supplies the bias ; at (c) a battery is used

useless to attempt to measure the grid bias at the grid of the valve, and it is in fact dangerous from the point of view of valve life to attempt to do so. The resistance of the grid circuit of most valves is so high that the connection of any ordinary meter to the valve grid will reduce the bias actually applied to the valve to perhaps one-tenth of its normal value, and it is obvious that this is likely to prove harmful to the valve. The grid bias, therefore, must be measured at its source and not on the valve. In Fig. 6 (c) the voltage across the bias battery should be checked ; in (b) the voltage across the bias resistance must be measured with the voltmeter joined between negative H.T. and the chassis.

Cathode-Bias Resistances

When dealing with receivers in which cathode-bias resistances are used (a), and they are probably the majority, the negative terminal of the meter can be left connected to the chassis, for all voltages are positive with respect to this point. The grid bias is now the voltage between chassis and cathode,

CURRENT AND VOLTAGE TESTING

and although it is usually listed as the grid voltage it is much better and clearer to call it the cathode voltage.

The voltage measured between anode and chassis is easily seen to be not the true anode voltage but the sum of the anode and cathode voltages. The difference is usually insignificant, except in the case of output valves, for the anode voltage is usually 150–250 volts and the cathode voltage is rarely greater than 0.5–3 volts, unless a manual volume control operating on a variable-mu valve is used. Apart from these exceptions, the difference between the true anode voltage and that measured from the chassis is negligibly small, and is often less than the permissible error in the meter.

In the case of many output valves, however, it is important to distinguish between the two figures. With a PX4 valve, for instance, the true anode voltage might be 250 volts and the grid bias — 33 volts. Taking all measurements from the chassis, therefore, the cathode (filament in this case) would be + 33 volts and the anode + 283 volts. The difference is even greater with valves of the LS6A type, for the grid bias is — 93 volts for an anode potential of 400 volts, and it is obvious that much confusion may arise if care is not taken to distinguish between the two methods of measurement.

Similarity with a Variable-Mu Valve

A similar case arises with a variable-mu valve having a manual volume control of the types shown in Fig. 7. Volume is controlled by varying the grid bias applied to the valve, and in each case it is really the cathode voltage which changes. At (a) the cathode voltage is a minimum when the slider of the potentiometer is nearest the earth line, and at (b) when the variable resistance is a minimum. Measurement will then indicate normal voltages, perhaps 200 for the anode and 80 for the screen grid. When the volume control is set for weakest volume, however, the apparent potential of the anode may be 250–300 volts and that of the screen grid 120 volts or so. The cathode, however, may be 30–40 volts positive with respect to the chassis so that the true anode and screen voltages are the apparent values less the cathode voltage, and the rise in voltage is much less marked than it appears.

It should, of course, always be remembered that no voltmeter of the current-consuming type ever indicates exactly the voltage existing in the circuit when the voltmeter is absent; it only shows the voltage existing while it is connected. This is due to the fact that the voltmeter itself consumes a certain amount

WIRELESS SERVICING MANUAL

of power which must be supplied by the circuit to which it is connected. In order that the readings may be reasonably accurate in circuits not having a good voltage regulation it is necessary, therefore, for the resistance of the meter to be high compared with that of the circuit across which it is connected.

If the voltage at a point of poor regulation—the anode voltage of a resistance-coupled valve, for instance—is measured by two different voltmeters of different resistances, the readings will not be the same. The lower resistance meter will show the lower voltage. It will be understood, of course, that if both meters were simultaneously connected to the circuit, they would read alike, but their indication would be less than that given by either alone.

It will be clear therefore, that, to be of certain help in diagnosing faults in a receiver, the voltage readings must be properly interpreted. Absolute reliance can be placed upon them only when there is knowledge of the indications which should be given by the particular meter used. In spite of this, they are of great value, for the errors introduced by the meter

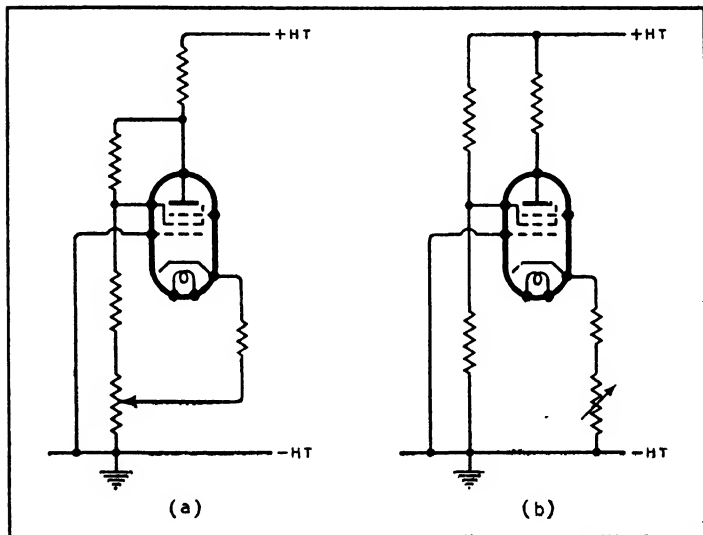

Fig. 7 : Two methods of manual volume control are employed with variable-mu valves ; at (a) a potentiometer controls the cathode voltage, and at (b) the same effect is secured by a variable resistance

CURRENT AND VOLTAGE TESTING

in taking measurements in the average receiver are only likely to be misleading at certain points, since the errors introduced are unlikely to exceed about 10 per cent. and variations between components and valves may easily cause such a discrepancy without seriously affecting the performance. The serious errors occur only in circuits of poor regulation and it is then easy to check in a different manner.

Using the Milliammeter

Current measurements do not suffer from the same tendency to inaccuracy, for, although the meter must consume some power, in practically every wireless circuit its resistance is negligible in comparison with the circuit resistance. Current measurements, therefore, can be relied upon absolutely, the sole

limitation being the accuracy of the meter itself. In practice, the only precautions which it is necessary to take are to see that no current flows through the meter other than that which it is desired to measure, and to make sure that its introduction to the circuit does not cause instability.

The milliammeter must be included in series with the circuit, so that it is somewhat more troublesome to use than a voltmeter. Referring to Fig. 8, the meter can be inserted at any convenient point between positive H.T. and the anode of the valve, and at whichever point it be inserted the reading will be the same. Where possible, however, it is wise to include the meter between the decoupling resistance R_1 and the H.T. line, for although the current is the same in all parts of a series circuit, the leads to the meter may introduce instability in certain circuits if the meter be included at other points. Instability, of course, is likely to cause a big change in the anode current of the valve and so render the reading useless.

In general testing, however, it is often inconvenient to include the meter in the theoretically correct position, for it

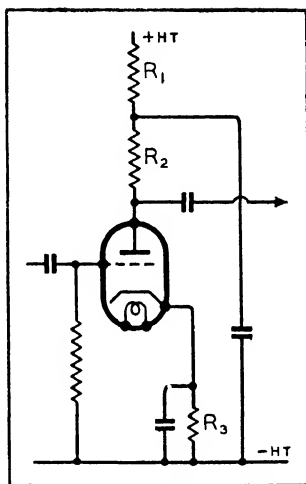

Fig. 8: When measuring the anode current of a valve it is wise to include the milliammeter at a point of low A.C. potential, generally between the decoupling resistance R_1 and the H.T. line

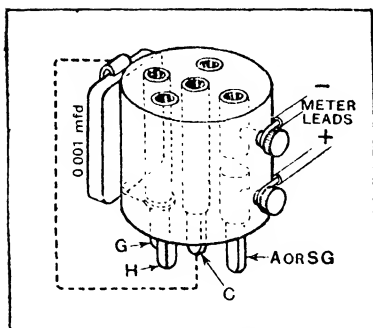

Fig. 9 : A split-anode valve adaptor is a valuable asset to the measurement of anode current, and to prevent its promoting instability a condenser should be wired between grid and cathode

way the wiring of the set. It is consequently very easy and speedy to take readings of anode and screen currents. It must be remembered, however, that since the meter is connected directly to the valve anode, its presence may introduce instability.

No trouble is usually found in A.F. circuits, and a split-anode adaptor can be used with impunity in all ordinary apparatus. In the case of R.F. and I.F. stages, however, it is another matter, and to prevent oscillation, it is a wise plan to short-circuit the coil in the grid circuit of the valve. The tuning condenser should not be short-circuited since in many cases this would alter the grid bias on the valve. As an alternative to the short-circuit, a condenser of $0.0001 \mu\text{F}$ or so could be connected between grid and chassis so that the input circuit is widely mistuned and instability made most unlikely.

The most convenient course is to mount such a condenser on the adaptor itself, wired between grid and cathode, so that its insertion becomes automatic, and this is shown in Fig. 9. Although the adaptor is unnecessary when taking anode current readings with screen-grid valves having top-anode connections, being then used only for screen current, it should still be employed and the leads from it shorted in order that the grid-cathode condenser may remain in circuit.

A five-pin adaptor will enable measurements to be taken throughout the older mains sets and many battery sets; in some cases, however, a four-pin adaptor is needed for the

involves the identification of the decoupling resistance, the unsoldering of the lead to one end of it, and the insertion of the meter. With valves having a top-cap anode terminal, it is obviously much simpler to insert the meter between the valve terminal and the lead itself, while when the anode is brought out to a pin in the valve-base, the use of a split-anode valve adaptor enables the meter to be connected without disturbing in any

CURRENT AND VOLTAGE TESTING

latter, depending on whether the valveholders will permit the passage of the centre-pin or not. Later receivers demand a seven-pin adaptor in addition, and a few sets, a nine-pin adaptor. Nowadays, however, octal-base valves are most frequently used, so that quite a large range of adaptors is needed if one is to be equipped to deal with all sets in this way.



Fig. 10 : The Ferranti A.C. Test Set : similar equipment is available for D.C. measurements

CHAPTER 3

THE INTERPRETATION OF METER READINGS

THE great advantage of voltage and current testing is that in many cases it leads one by a very short path to the source of the trouble. The first step, of course, is to check the voltages on all the valves of the receiver, and the currents passed by their anodes and screen-grids. Often it will be found that in one or two places the meter readings are markedly different from the correct ones, and it may then be possible to cut short the procedure and investigate the circuits of the valve concerned straight away.

In general, however, the figures should be tabulated, and it is convenient to have a standard set of forms for this purpose. In this way full data on the receiver are available for reference at any time and are useful not only in the event of that particular set developing a fault at a later date, but also when one has another receiver of the same type for repair. Moreover, if one has many sets of the same model to service and a careful record be kept of the defects and periodically examined, the commonest fault is soon revealed and often leads to a short-cut in investigating those models.

Having obtained a set of figures for a receiver, it is necessary to interpret them correctly if they are to be of value. Suppose that both voltages and currents are below normal throughout the receiver, what does this mean? It is at once obvious that the most probable cause is a defective rectifier valve, if the set be of the A.C. or A.C./D.C. type, or a run-down H.T. battery with a battery set. In the latter case, however, the defect should have been found earlier, for in testing a battery set the first thing to do is always to check the batteries *under load*.

Reverting to the mains set, if the rectifier is not at fault, low output can be due only to subnormal voltages on the secondaries of the mains transformer, or to a low-resistance leak in one of the smoothing condensers. The mains voltage will have been checked during the general testing and if it be low may account for the trouble. Do not forget to check that the mains are connected to the correct tappings on the primary.

If the mains voltage is low, it is tempting to correct for it by altering the connections to the transformer, but it is hardly safe to do so. Low mains voltage usually occurs when the house is a considerable distance from a sub-station, and is due to the voltage drop in the cables. This voltage drop varies with the

THE INTERPRETATION OF METER READINGS

current and is likely to be at its greatest on a winter evening when there is a big consumption for lighting and heating. In the daytime, however, the load may be small, and the voltage drop negligible. The voltage is then often above the nominal voltage, for the supply at the sub-station is usually somewhat higher than the nominal voltage in order to compensate for the loss in the cables.

In cases of very bad regulation, 240-volts mains may deliver a supply at as much as 260 volts in the daytime and as little as 215 volts at night. Such cases are quite rare, however, and in general the fluctuations are kept within the limits of ± 4 per cent. It can be seen that the wide fluctuations sometimes found render it unsafe to compensate for low voltage by altering the tapping on the mains transformer primary, for abnormally low voltages usually mean wide variations and a correspondingly high voltage at other times.

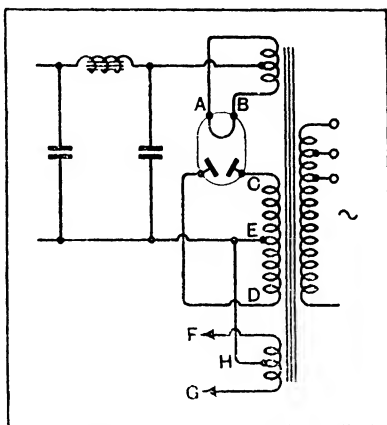

Fig. 11 : A typical circuit of mains equipment, showing the points at which A.C. voltage measurements should be taken

The Mains Equipment

If the mains voltage be correct, the mains transformer secondary voltage should be checked with an A.C. meter. The total R.M.S. voltage across the H.T. secondary rarely exceeds 1,000 volts even with large output stages, and can consequently be measured with a meter having a slightly higher full-scale reading, such as 1,200 volts, by connecting it across the full winding (points CD, Fig. 11). Care should be taken to use thoroughly insulated test prods for the terminations to the meter leads.

If the meter does not read high enough for this measurement, each half of the winding can be checked separately by connecting the meter first to CE and then to DE, and adding the figures to obtain the full voltage. Ideally, the voltages across the two

WIRELESS SERVICING MANUAL

halves of the winding should be the same, but in practice they may differ slightly.

The filament voltage of the rectifier should be measured with the meter connected at AB, directly to the filament legs of the valve-holder, in order to allow for the drop in the connecting leads. In modern sets it is usually either 4 or 5 volts according to the type of rectifier valve, but in old sets voltages of 7.5 volts and 5.5 volts were often used. Although the A.C. voltage is small, do not forget that the filament of this valve is anything up to 500 volts more positive than the chassis, and connect the meter with care.

Now if the voltages throughout the receiver are abnormally high, but the currents about normal or somewhat low, the most probable cause is low heater voltage on the valves and this should be checked by connecting an A.C. voltmeter to the valve-heaters themselves. If the voltages are low, check the output of the mains transformer (FG, Fig. 11) and if this is correct the trouble obviously lies in the connecting leads.

When the transformer gives an output of 4 volts and the valves require 4 volts, the connecting leads should not be of thinner wire than No. 16 gauge or its equivalent in stranded wire. Even with this gauge, an appreciable drop will occur if there are many valves. In commercial sets, therefore, the secondary voltage is often made slightly greater than 4 volts to allow for the drop in the wiring. The lower current taken by modern 6.3-volt valves has greatly eased matters, and specially heavy conductors for the heater wiring are rarely necessary with such valves. Incidentally, the accuracy of the position of the centre-tap can be checked by measuring the voltages across the two halves (FH, GH, Fig. 11)—they should be equal.

When interpreting the figures for a receiver, the most important thing to remember is that a high anode voltage should be accompanied by a high anode current if all is in order in the particular circuit to which the figures apply. In the case of pentodes and screen-grid valves, however, the anode current is not greatly affected by the anode voltage, but is very dependent on the screen potential, a high voltage at this point leading to a marked increase in anode current.

Cathode Bias

When cathode bias is used, however, the increase in anode current will not be proportional to the rise in anode voltage. Thus, suppose that when investigating an output stage the

THE INTERPRETATION OF METER READINGS

valve is found to have an anode potential (anode-cathode) of 300 volts and it passes a current of 55 mA, whereas the correct figures are 250 volts and 48 mA. The probability is that there is nothing wrong with this stage and that the unusual operating conditions are due to the output of the mains equipment being unusually high.

This is easily seen by running over the possible faults and their symptoms. If the valve had lost its emission or its filament voltage were low, the anode current would be below normal; this would mean a smaller load on the mains equipment, and the anode voltage would consequently be normal to extra high, depending on the H.T. regulation. If the bias resistance had increased its value, the same thing would happen, but the cathode voltage would also be high. Similarly, a failure of the grid bias supply to reach the grid of the valve would result in a heavy anode current with a low anode voltage. If this defect were in the grid circuit of the valve, the cathode volts would also be high, whereas if it were due to the bias circuit they would be low.

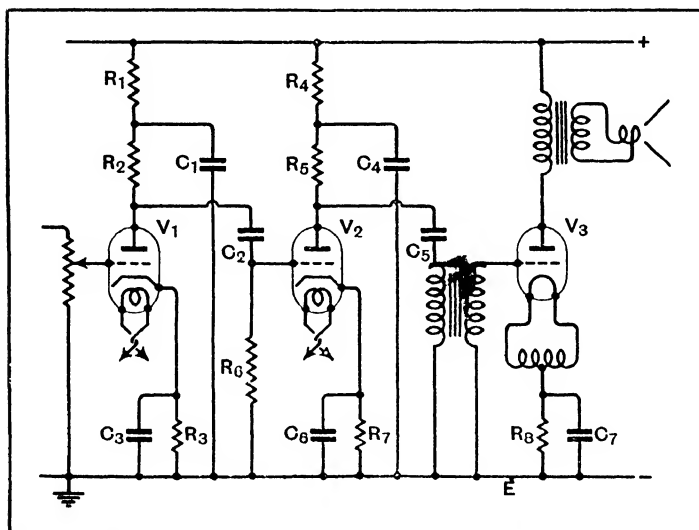

Fig. 12 : Audio-frequency amplifiers of this type were at one time widely employed, and lend themselves well to illustrating the methods of set testing, since both resistance and transformer couplings are used

WIRELESS SERVICING MANUAL

Checking the A.F. Amplifier

The matter is probably most clearly seen from Fig. 12, which shows an A.F. amplifier embodying both resistance and transformer coupling. The first step is to measure the anode and cathode voltages of V_3 from the earth line E, and the difference between them gives the true anode-cathode voltage; then check the anode current. If any abnormality cannot be explained by the voltage of the H.T. line being high or low, the trouble must lie in V_3 or its immediately associated circuits.

Check the value of the bias resistance R_8 with an ohmmeter, or from the voltage and current readings, R (in ohms) = Volts across R /Current through R in amperes. If the resistance is too low, the resistance itself may not be at fault, but the by-pass condenser C_7 . If all be in order, short-circuit the A.F. transformer secondary. If this brings things back to normal an open-circuit in the transformer secondary should be suspected and the winding checked for continuity with an ohmmeter. Should it be found continuous, the trouble is probably parasitic oscillation, and grid and anode stopping resistances should be inserted.

The Previous Stage

In the previous stage, the possible faults are greater in number but just as easy to determine. Suppose the check on the valve conditions reveals low anode voltage and current. The trouble cannot then be due to V_2 itself, for although low heater voltage or a loss of emission would cause low anode current, it would make the anode voltage abnormally high. The voltage at the junction of the coupling and decoupling resistances R_5 and R_4 should be checked, therefore. If it be nearly the full line voltage, the trouble is an open circuit in R_5 , but if it be below normal a leak in C_4 or C_5 should be suspected.

In this connection, it should be remembered that if C_4 is an electrolytic condenser it is normal for it to pass a slight current, up to about 1 mA. Should the anode voltage be practically zero, but some voltage be present at the junction of R_4 and R_5 , a short-circuit in C_5 is almost certain, but if the voltage at both points is zero, then the short-circuit is in C_4 .

When the anode current is high, however, but the anode voltage low, the trouble lies in the grid or cathode circuits. The cathode circuit is exempt from suspicion if it be found that the product of the bias resistance R_7 (in ohms) and the anode current (in amperes) equals the measured cathode voltage.

THE INTERPRETATION OF METER READINGS

Approximate agreement is good enough, for the measured voltage may be somewhat below the true value owing to the load of the voltmeter. If the measured voltage be very low, check R7, C6, and the heater-cathode insulation of the valve. It is useless to do this last with the heater cold. When the cathode circuit is found to be correct, short-circuit the grid leak R6. If the currents and voltages then become normal, the trouble is a leaky condenser C2.

A very small leak in such a condenser can completely upset the conditions of the following valve. Thus suppose that V1 operates with an anode potential of 100 volts and that R6 is 0.25 megohm. Then a leak of 20 megohms in C2 will result in the grid of V2 being $\frac{100 \times 0.25}{20.25} = 1.24$ volts positive with respect to the earth line. If the cathode potential of V2 is 3 volts, the true grid voltage with respect to the cathode will be not -3 volts, but $1.24 - 3 = -1.76$ volts only. An internal resistance lower than 20 megohms in C2 will naturally result in a still lower effective grid bias on V2, and it may become positive instead of negative.

Grid Circuit Conditions

The grid circuit conditions can always be checked by shorting the grid directly to the source of bias, in this case by shorting R6. If there is a change of anode current, then it is certain that there is current flowing in the grid circuit; either the valve itself is passing grid current due to incorrect operating voltages or to its being defective, or some other circuit is causing a current to flow through the grid circuit.

It is readily seen that where resistance-coupling is used before the output valve, any leak in the coupling condenser may seriously damage the output valve and possibly the H.T. rectifier as well, for all anode circuit components are of fairly low resistance and a very heavy anode current may flow. For this reason, the coupling condenser to the output valve is sometimes of the mica-dielectric type. Damage to the valves is unlikely through this fault in earlier stages, for the early valves have high resistance anode circuits which limit the possible anode current to a figure which the valve can easily withstand.

The valves employed in R.F. and I.F. stages are usually of the screened pentode type. With these the rules for circuit testing are in no way different from those applicable to the triode, save that it must be remembered that with all such

WIRELESS SERVICING MANUAL

valves operating under normal conditions the screen potential exercises a much greater effect upon the anode current than does the anode voltage. In the case of screened-tetrodes the screen current is a very variable quantity, and one specimen may pass two or three times the current of another equally good one.

Sometimes, too, the screen-current is reversed, or negative, without the valve being in any way defective. Pentodes are more consistent and the negative current effect is rarely, if ever, found; the screen current is higher, however, and in the case of R.F. pentodes it is often about 2 mA. With an output pentode, of course, the screen (really the space-charge grid) current is usually 8-15 mA.

When checking voltages and currents in any part of the receiver, but particularly when testing the pre-detector stages, the volume control should be at maximum, unless it be a purely A.F. control, and the set mistuned from any signal. Unless this is done, many readings are bound to be inaccurate and will lead one on a wild goose chase. If the set is tuned to a signal, for instance, A.V.C. will bias back certain valves and reduce their anode and screen currents and cause a rise in certain voltages.

Resistance Testing

When voltage and current testing fails to indicate a fault, or when it shows one to be present but fails to reveal its exact nature, it may often be found by resistance testing. This is merely an elaboration of continuity testing, using an ohmmeter for the purpose. A break in the primary winding of an A.F. transformer would certainly be shown up by the voltage and current tests if the primary is directly fed, but not if it be resistance-capacity fed in the modern way. It may be checked instantly with the ohmmeter, however, simply by connecting the meter leads to the primary terminals. Similarly with the secondary, the ohmmeter will infallibly reveal a break in the winding, whereas with other tests there is an element of uncertainty.

The ohmmeter is of the greatest value, however, in the R.F. circuits, for the operation of wavechange switches and the continuity of coils may be readily checked. In a set covering the medium- and long-wavebands only, waveband switching is often arranged on the lines shown in Fig. 13 for one circuit, and the switch is open for the long waveband. If the switch be set for the long waves and the ohmmeter connected across both coils at the points AC, it will show the total D.C. resistance of both coils, usually about 10-40 ohms.

THE INTERPRETATION OF METER READINGS

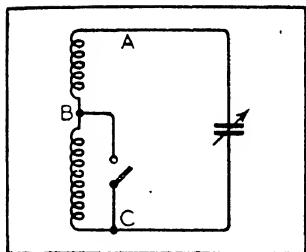

Fig. 13 : A wavechange switch can be checked by connecting an ohmmeter at AC, to determine whether the resistance changes on operating the switch

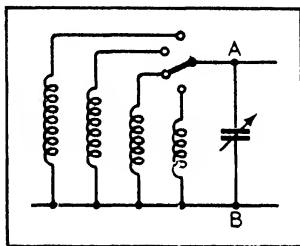

Fig. 14 : This diagram shows a typical method of waveband switching for an "all-wave" set

Moving the switch to the medium waveband should short-circuit the long wave coil, and the meter should indicate the resistance of the medium wave coil, some 1-5 ohms. If the meter reading does not change, obviously the switch is not making contact. Even if a change of reading of the expected order is obtained, however, it is not certain that the switch contact is good.

This may be determined by connecting the meter directly across the medium wave coil (AB) and noting the resistance. The figure should be the same as with the switch closed and the meter connected across both coils (AC). It cannot be greater but may be less; if it appears greater there is a bad connection to the meter. The difference of the readings represents the resistance of the switch contacts. A contact resistance of 0.1 ohm may not materially impair the performance of the receiver, though a resistance of 1 ohm will certainly do so, but on the medium waveband only.

In multi-band sets the waveband switching usually takes the form shown in Fig. 14. If the ohmmeter is connected across AB, it will indicate different resistances on the medium and long wavebands, and still lower resistance on the short waves. The short-wave coils are of such low D.C. resistance, however that the average ohmmeter will indicate zero. The test will show up an open-circuit in a coil or switch contact, but will not necessarily reveal a bad contact of sufficient magnitude seriously to affect the short-wave performance. This is because the tolerable resistance in a switch contact becomes smaller as the coil resistance gets lower.

When checking primary and reaction windings the resistance

WIRELESS SERVICING MANUAL

may be found to be the same in both positions of the switch. This does not always mean a fault, for in some sets these windings are the same on both wavebands. Again, in a few cases such coils will be found to have a surprisingly high resistance, perhaps 250 ohms. This is because primaries and reaction coils are sometimes wound with resistance wire in order to prevent parasitic oscillation and, in the case of an oscillator, to keep the output at a fairly even level over the waveband.

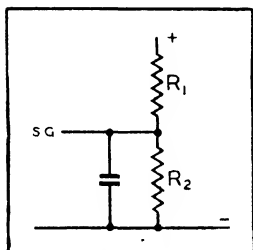

Fig. 15 : When checking for a leak in a condenser, it should always be disconnected. If left in circuit misleading results may be obtained through the presence of resistances

circuit, as shown in Fig. 15, for instance. If an internal leak is suspected, it is of little use connecting the ohmmeter across it while it is still connected to the voltage divider, for the meter will in any case read the resistance of R_2 . It should be disconnected at one end and checked alone. If the test is for a short-circuit only, however, then disconnection is unnecessary. The meter will give a reading, it is true, even if the condenser is in order, but it will show the value of R_2 —5,000–20,000 ohms—whereas with a short-circuited condenser it will read 0–100 ohms.

When searching for open circuits, the ohmmeter is just as useful, for when connected to the circuit at fault it will continue to read infinity instead of showing the correct resistance. It is most useful when searching for a disconnection in the wiring, for there are many cases where a joint may be passed by a visual inspection as sound, but a resistance test immediately reveals it to be defective.

In order to avoid false readings and the possibility of damage to the meter, the set should always be switched off, or if a battery set, disconnected from its batteries, when using an ohmmeter. Care should also be taken to see that the circuit under test is really the only one connected to the meter, for there are many cases where an alternative path may exist. The meter cannot tell the difference between different circuits and it only shows the resistance between the two points to which it is connected.

Take the case of the by-pass condenser in the screen-grid

CHAPTER 4

VALVES

WHEN a fault develops in a receiver, it is the valves which are usually first suspected because they are not only subject to failure like any other component but they most definitely wear out with use. Unfortunately, they are much more difficult to test properly than are most components. Unless proper testing equipment is available, the best course is undoubtedly to substitute a new valve in the receiver.

As there are over 600 current types, to say nothing of the American valves used in imported sets or the obsolete types which are still used in many old receivers, this method is obviously out of the question in general servicing. Where only a moderate number of types of receiver is handled, of course, it is quite possible to keep a set of suitable valves in stock and this is to be strongly recommended.

Proper testing gear which can be relied upon to detect any fault in a valve is complicated and expensive. As the majority of faults can with a little skill be detected while the valve is in the set, this course will appeal to the majority. Short-circuits between the electrodes, or a broken heater or filament can, of course, be readily detected by connecting an ohmmeter to the various valve pins.

Defective heater-cathode insulation cannot often be detected in this way, however, for it usually appears only when the cathode has attained its normal working temperature. Sometimes, too, it is intermittent and may not appear until the set has been in operation for an hour or so, and then only for a few minutes. In most circuits, the bias resistance is connected between cathode and chassis, and the centre-tap on the filament winding of the transformer is joined to the chassis. Poor heater-cathode insulation consequently partially or completely short-circuits the bias resistance and the fault is most easily detected with a voltmeter between cathode and chassis, for when the breakdown occurs the cathode voltage becomes much below its normal figure. If the fault is intermittent it is naturally much more difficult to trace, and the only course is to leave the voltmeter in circuit until it occurs.

Microphonic and noisy valves can generally be detected by tapping them, but with certain kinds of noise, notably hiss, the only certain test is replacement with a good specimen. A

WIRELESS SERVICING MANUAL

valve which introduces mains hum does not normally need special tests for it will be located during the process of carrying out the normal hum tests described in a later chapter.

Emission Falling Off

The end of the normal life of a valve is generally set by a falling off in the emission. With a battery set, this may often be detected through the anode current being abnormally low for the voltages applied to the valve. With a mains set, however, this test is of little use, except when the valve is in the last stages of decrepitude, for the automatic grid bias circuit tends to keep the anode current up, and the current may not be much below normal when the valve has deteriorated considerably.

The best test is undoubtedly the measurement of mutual conductance. This is not as difficult as it sounds, and rough measurements can be made quite easily. The mutual conductance is actually a change of anode current divided by the change of grid voltage necessary to produce it. If arrangements be made to operate the valve under suitable conditions and at a certain grid bias, therefore, the difference between the anode currents obtained at this bias and when it is changed by 1 volt gives the mutual conductance directly in mA/V.

The circuit of a suitable valve tester is shown in Fig. 16 and with triodes the standard voltages for tests are 100 volts H.T. and zero grid bias.

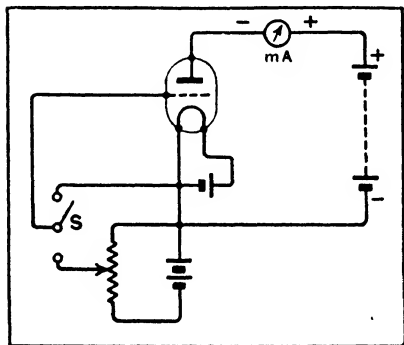

Fig. 16 : A simple valve-tester can be built with this circuit. If the switch changes the grid bias by 1 volt the change of anode current (mA) gives the mutual conductance (mA/V) directly

should be of fairly low resistance, say 500 ohms, should be set so that it is 1 volt negative with respect to negative H.T. The switch S should be set to the upper position for zero grid bias and the anode current noted ; the switch is then thrown to the lower position and the new value of anode current noted. The difference between the two readings gives the mutual conductance. Thus, if the current with zero grid volts is

VALVES



Taylor Model 47A Valve
Tester

10 mA and with 1 volt bias it is 8.3 mA, the mutual conductance is $10-8.3 = 1.7$ mA/V. The arrangement may, of course, be used also with screen-grid, R.F. pentode, and output pentode valves, but it is necessary to provide a tapping on the H.T. battery of suitable voltage for the screen.

If many valves have to be checked it is a good plan to wire up a number of valve-holders permanently, one for each different class of valve, together with suitable batteries, meter, and switching. Any valve can then be given a rough test for mutual conductance at a moment's notice.

A still simpler method of measuring mutual conductance is possible when an A.C. supply is available. The D.C. meter of Fig. 16 is replaced by an A.C. milliammeter connected to the anode circuit through a suitable transformer, and a known A.C. voltage is applied to the grid of the valve by means of a transformer. The meter then reads the A.C. anode current produced by a known A.C. grid voltage and it can be calibrated directly in mutual conductance. If the tester is kept permanently wired up to suitable batteries, therefore, it is only necessary to plug in a valve and read off its mutual conductance from the meter, no switching or calculation being necessary. The

WIRELESS SERVICING MANUAL

method is not, of course, highly accurate, but it is convenient and quite good enough to enable good and bad specimens to be distinguished with certainty.

For accurate results, of course, a proper bridge is necessary. This need not be complicated, however, for good results can be obtained with fairly simple equipment such as that described in Appendix IV. Apparatus of this nature enables accurate measurements of mutual conductance to be made over the wide range of 10.0 mA/V to 0.01 mA/V.

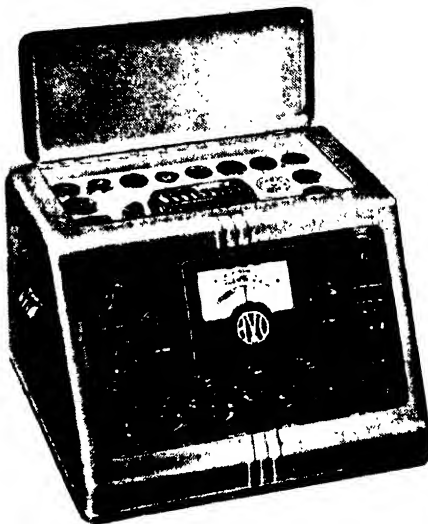

'Avo' Valve Characteristic Meter

CHAPTER 5

TRACING MAINS HUM

ALTHOUGH mains hum is a particularly annoying defect in a receiver, it is one which is usually easy to cure. The number of points at which hum may enter a receiver is limited, and the search for the cause of the trouble, whether the receiver be new or old, resolves itself into a systematic checking of the various circuits. Fundamentally the problems encountered are the same in A.C., D.C., and A.C./D.C. sets, but the two last sometimes present special difficulties not met with in purely A.C. models.

The simpler case of an A.C. set will be considered first, therefore, for most of the treatment is applicable to other types. The method of tracing hum is the logical one of stage by stage testing, starting at the loud-speaker and working backwards to the aerial; if the process be carried out correctly this system infallibly reveals the cause of the trouble, and then it is usually easy to devise a remedy. The procedure is best illustrated by an example and the circuit of Fig. 17 forms a good basis for discussion. This circuit is not one which is now commonly employed, although it has been widely used in the past; it is, however, particularly suited to our present purposes, since most of the different forms of mains hum can occur with it.

The first step in testing is to absolve the loud-speaker from blame, for it is obvious that if the hum is occurring in this it is a waste of time to investigate the receiver proper. Hum in the loud-speaker occurs when the current energising the field winding has an appreciable ripple on it and a hum-bucking coil is not fitted.

In order to determine whether or not such hum is present, disconnect the output transformer primary and join together the two leads which are normally connected to it, in order that H.T. may be applied to the output valve and the load on the mains transformer maintained at its normal figure. Then connect a resistance across the transformer primary having a value approximately equal to the internal A.C. resistance of the output valve, so that the transformer is normally loaded. The A.C. resistance can be found from the valve-maker's catalogue or from the *Wireless World* Valve Data Supplement. Then switch on the set and listen for hum. If it be present, it is occurring in the field or is being picked up by the output

WIRELESS SERVICING MANUAL

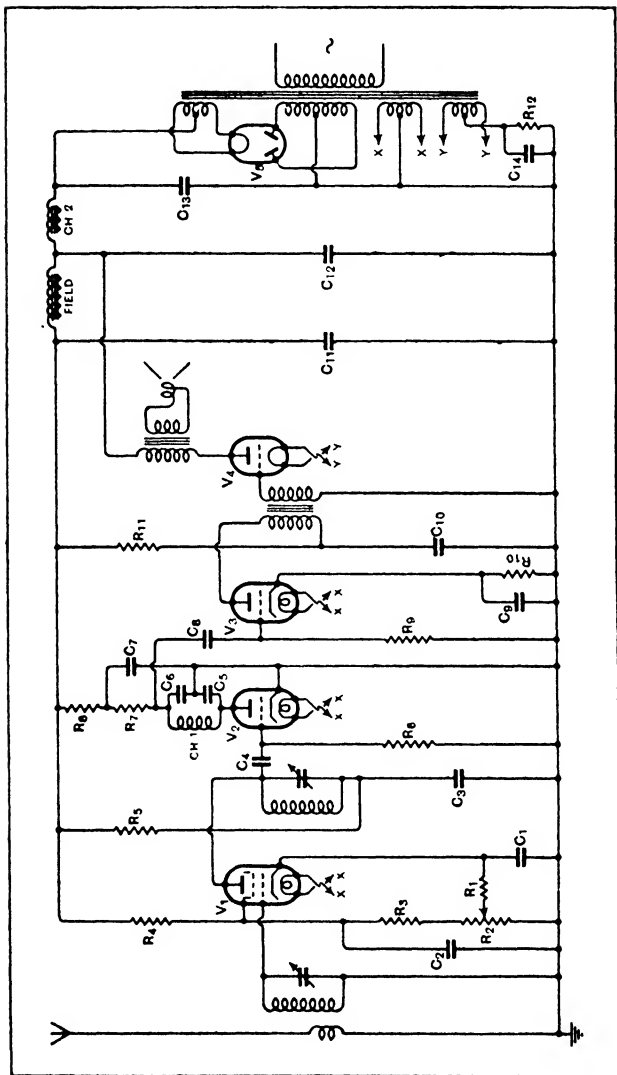

Fig. 17 : This circuit diagram, although not one which is widely used nowadays, is particularly well adapted for illustrating the methods of tracing hum

TRACING MAINS HUM

transformer. The second is very unlikely, but the first is fairly common.

The cheapest remedy is to send the speaker back to the makers for the addition of a hum-bucking coil; this usually removes 90 per cent. of the hum, but it often leaves a trace of fairly high-pitched hum, which is often not enough to be troublesome. The alternative remedy is to smooth the field current; if sufficient smoothing is used this is a certain and complete cure.

The Speaker Field Supply

With the circuit of Fig. 17, hum of this nature should not occur, for the field current is smoothed by CH2 and C12, which also provide the smoothing for the output stage and initial smoothing for the early stages. If hum does occur with an arrangement of this nature, it probably means that C12 or CH2 is defective, but the absence of speaker-field hum is not proof that these components are in order.

In practice, this type of hum occurs chiefly when the field is separately energized, but it may occur in cheap sets where the field winding forms the only smoothing choke in the set and the speaker is not well hum-bucked. In such cases the best remedy is to insert a choke in series with the field winding, on the rectifier side of the winding, and to connect a condenser to negative H.T. from their junction.

This is shown in Fig. 18, in which C1 and C3 are the condensers normally fitted, and CH and C2 are the new components.

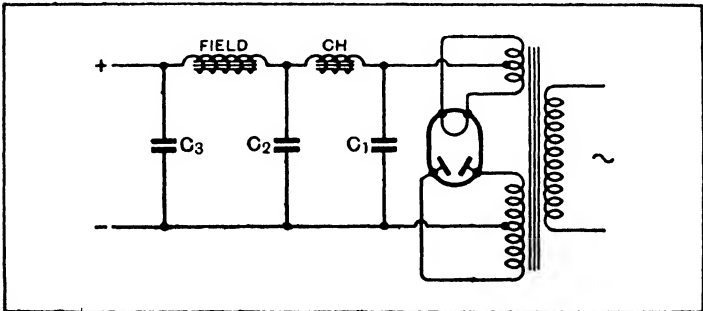

Fig. 18 : Hum which comes from the speaker field supply can be stopped by connecting a choke and condenser before the field

WIRELESS SERVICING MANUAL

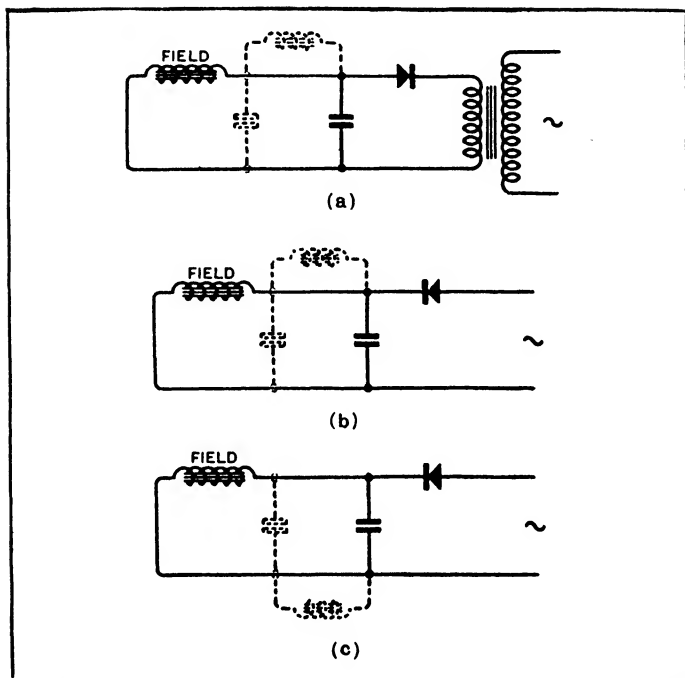

Fig. 19 : With a separately energized speaker smoothing may be needed to prevent hum. When the field is of low voltage (a) the condensers should be $200\ \mu\text{F}$ or more, and the choke of only 1 or 2 ohms resistance, but with a high-resistance field (b and c) $8\ \mu\text{F}$ condensers are suitable with an ordinary choke

The choke need have an inductance of no more than 8 H. or 10 H. at the maximum current taken through the field, but it must be of low D.C. resistance if it is not to drop the H.T. voltage considerably. For convenience the condenser C_2 will in most cases take the form of an $8\ \mu\text{F}$ electrolytic.

Where the field is separately energized, the commonest arrangements are shown in Fig. 19. A low-voltage heavy-current field (a) is often very difficult to treat, for the resistance of the smoothing choke can rarely be allowed to exceed 1. or 2 ohms : the inductance, therefore, can only be a fraction of a henry and capacity must chiefly be relied upon for smoothing. Fortunately, electrolytic condensers of $200\ \mu\text{F}$ or so can be obtained quite cheaply.

TRACING MAINS HUM

Very largely on account of the difficulty of eliminating hum, low-voltage fields are now little used, and the usual arrangement is that of Fig. 19 (b) with a field having a resistance of 2,000–6,000 ohms. Here smoothing is easy and a 10 H. choke and 8 μ F condenser should readily remove all traces of hum. If they do not, try the choke and condenser on the other side of the field, as in (c), for as no mains transformer is used the results may be affected by the earthing system of the mains.

When hum from the speaker field has been proved to be absent, or remedied if present, the connections of the output transformer should be replaced to normal. If hum is now present, short-circuit the input circuit of the output valve—the A.F. transformer secondary in Fig. 17—or the grid leak in the case of a resistance amplifier. If the hum continues the defect lies in the circuits still operative, whereas if it ceases it is obviously coming from an earlier stage.

The Output Stage

Assuming that the hum continues, it can only be due to the output valve, or its H.T., bias, or filament supplies: in the case of a pentode, there is also the space-charge grid H.T. supply. The anode supply can be tested by removing the output valve and connecting a resistance between negative H.T. and the anode socket of the valve-holder; the value of the resistance should be such that the normal current flows through the output transformer. With a PX4 valve, for instance, the anode voltage is 250 volts and the current 48 mA; its resistance to D.C. is thus $250/0.048 = 5,200$ ohms. The resistance, of course, should be of at least 12 watts rating, and its exact value is unimportant. In this case, 5,000 ohms would be quite near enough.

If the hum continues with this resistance in place of the valve, it can only be due to inadequate smoothing of the H.T. supply for this stage, and the choke and condensers should be checked. In extreme cases an additional

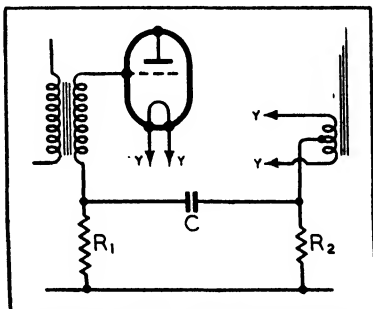

Fig. 20 : Hum from the grid bias source may often be prevented by grid-circuit decoupling

WIRELESS SERVICING MANUAL

stage of smoothing may be needed, but these should be very rare. When silence has been secured, replace the valve, and if there is again hum it can only be due to the bias or filament supplies. If the bias resistance by-pass condenser, C_{14} of Fig. 17, is over $25\mu\text{F}$, there should be no hum from this source and it is an easy matter to check it by temporarily connecting another in parallel.

If the condenser is small, however, it may be necessary to replace it by a large capacity or to decouple the grid circuit. The latter can only be done with transformer coupling and the connections are shown in Fig. 20, where R_2 is the bias resistance and R_1 the decoupling resistance of some 0.1 megohm. The condenser C should be about $1\mu\text{F}$; it must *not* be of the electrolytic type, since the leakage would reduce the effective grid bias with ruinous effects on the life of the valve.

Hum from the filament supply is likely only if the tapping on the mains transformer secondary is much out of centre or if the valve used has a low-current filament. In either case, the best results will be secured by using a potentiometer across the filament, instead of the centre-tap, as shown in Fig. 21, where R_1 is the bias resistance and C_1 is the by-pass condenser. The potentiometer P should have a value of some $15-30$ ohms and the slider should be adjusted for minimum hum.

Miniature potentiometers for this purpose are obtainable commercially from various firms, including Claude Lyons Ltd. In general, however, such potentiometers are needed only when the defect lies in the mains transformer tapping being off-centre.

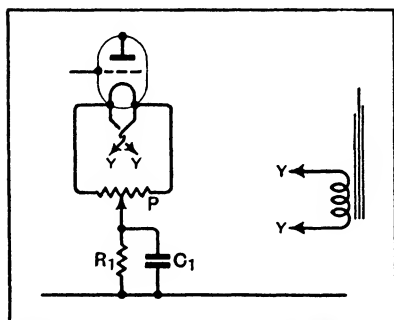

Fig. 21 : The use of a potentiometer P across the valve filament will tend to reduce hum from the LT supply when the mains transformer secondary is not accurately centre-tapped

With modern heavy-current valves, they are usually unnecessary, and almost invariably so with indirectly heated valves. Filament hum is usually serious only with the old 0.25 -ampere type valves, and if the use of a potentiometer does not cure it the only remedy is to change the valve for one consuming a heavier filament current.

With a pentode output valve, the

TRACING MAINS HUM

space-charge grid represents an additional possible source of hum and one which is, in fact, the most probable of all. The space-charge grid H.T. supply requires more smoothing than that of the anode, for any ripple on the supply is amplified to some degree by the valve. It is the common practice to feed this electrode from the same point in the smoothing equipment as the anode, and when this is satisfactory it really means that the anode supply is smoothed rather more than is strictly necessary.

When the anode supply is only smoothed just enough for hum to be avoided in this circuit, more smoothing is needed for the space-charge grid. In some cases, such additional smoothing can be secured by feeding the grid from a later point in the smoothing equipment; in others a simple filter is needed. Thus in Fig. 22 the insertion of a resistance R in the space-charge grid lead, with a by-pass condenser C , will usually effect a cure. The resistance R should be no larger than necessary, for it lowers the grid potential and so reduces the power output. It should be from 5,000 to 10,000 ohms and C can well be $8\mu\text{F}$, although smaller capacities will sometimes suffice. Where the voltage drop in a resistance cannot be permitted, R must be replaced by a choke. This is less expensive than it sounds, for as the current is only 8–10 mA quite a high inductance can be obtained cheaply. Whatever type of valve be used, it should always be remembered that in a push-pull output stage, serious mismatching of the valves may be a cause of hum. Since such a stage is not normally responsive to a ripple on the H.T. supply, less smoothing is often used than would be necessary with an ordinary output stage.

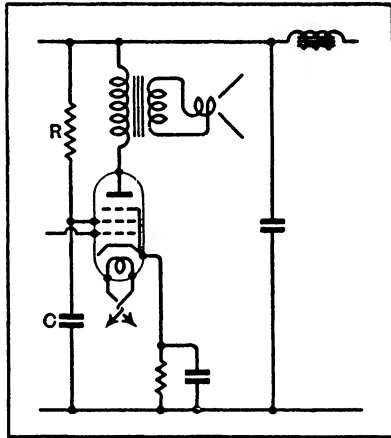

Fig. 22 : The space-charge grid of a pentode sometimes needs additional smoothing, which can be effected by a condenser C and resistance R . This resistance must not be of too high value otherwise there will be an excessive voltage drop across it

WIRELESS SERVICING MANUAL

The A.F. Transformer

When satisfied with the performance of the output stage the short-circuit on the input should be removed, and if hum now reappears the preceding stage must be tested. If transformer coupling is used, as in Fig. 17, the hum may be picked up by this component. This is easily tested, and the procedure is to disconnect the primary and to connect across it a resistance roughly equal to the valve resistance (V_3) in order to simulate working conditions.

If hum is now present which disappears on short-circuiting the secondary, it is quite certain that it is picked up by the transformer—usually from the mains transformer but sometimes from smoothing chokes. One remedy, of course, is to separate the components more widely, but this is often impracticable. Screening is of little or no value, and the only course is to orient the A.F. transformer to the position of minimum hum.

The transformer should be unscrewed from the chassis and flex leads fitted for the secondary connections. It can then be readily moved about in the set and the position of minimum hum determined; this position is very critical if the mains and A.F. transformers are close together, but may not be if they are more than a foot or so apart. Quite probably, the transformer will have to be tilted slightly, and as in some cases several minima can be found, the one chosen will naturally be that which gives the shortest leads or the easiest mounting.

Having mounted the transformer in such a position that the hum is negligible, the connections may be replaced to normal, and the operating conditions of the valve investigated. When the set is switched on again, it may be found that hum is again present but that this dies away as the valves warm up. This is due to hum pick-up in the transformer. Even when set for minimum hum, the pick-up is rarely zero and depends largely upon the degree of damping imposed upon it by the valve.

The lower the resistance of the valve feeding the transformer, the less likely is there to be hum, and it is for this reason that the connection of a resistance across the primary is recommended when orienting the transformer. If no resistance be used, the minimum may be ill-defined and is unlikely to be silent. Under working conditions, the transformer is damped by the valve resistance and correct operation is secured. When the set is first switched on, however, the resistance of V_3 (Fig. 17) is infinite, for the valve cathode takes 15 to 30 seconds to acquire its working temperature.

TRACING MAINS HUM

The directly heated output valve is operative almost at once, however, and hum is heard because the transformer is not damped by V3. As this latter valve warms up, the hum decreases, and ceases to be audible when it is working normally. This effect cannot be avoided without separating the transformers very greatly; but it may be reduced by using parallel-feed connections for the transformer. These are shown in Fig. 23.

Under normal conditions, the damping on the transformer primary is due to R_1 in parallel with the valve resistance, and when the valve heater is cold, to R_1 alone. Some change of damping is experienced as the valve warms up, of course, but it is much less than with a directly-fed transformer.

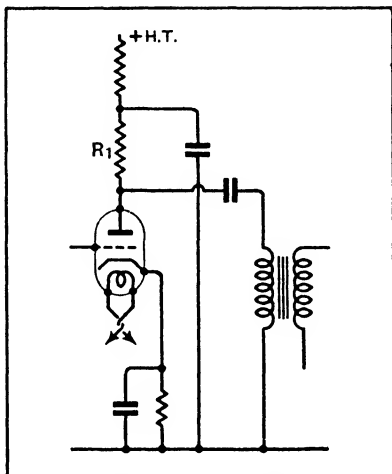

Fig. 23 : The connections for a resistance-capacity fed A.F. transformer

The A.F. Stage

Reverting to the question of hum during normal operation, when pick-up in the transformer has been satisfactorily eliminated, the next step is to test the circuits of the valve. Its input circuit should be short-circuited (R_9 of Fig. 17), and hum can then be due only to the valve, or its anode or bias supplies. It is usually possible to tell whether the valve is at fault or not by the character of the hum. If it is of fairly low pitch and perfectly steady and unchanging, the valve is unlikely to be at fault, but if the hum wanders in pitch or intensity, and particularly if it is of comparatively high pitch, then the trouble is almost certainly a faulty valve.

Assuming the valve to be in order, hum indicates a lack of smoothing in the H.T. supply, or inadequate by-passing of the bias resistance. The latter can be checked by trying a $50\mu\text{F}$

WIRELESS SERVICING MANUAL

condenser across it (C₉, Fig. 17). If the H.T. smoothing were initially in order, the hum can be due only to an open circuit in, or bad connection to, the decoupling condenser for this stage (C₁₀) or one of the smoothing condensers (C₁₁, C₁₂) or to short-circuited turns on one of the smoothing chokes. If the receiver has never been satisfactory from the point of view of hum, the same possibilities apply, but the trouble may really be due to insufficient smoothing equipment and an additional stage may be needed.

In this connection, it may be remarked that decoupling circuits give a very appreciable amount of smoothing, and hum may sometimes be remedied merely by increasing the capacity of a decoupling condenser.

When silent operation has been secured, the short-circuit on the input should be removed, and any hum now found must be coming from an earlier stage. If this is transformer coupled, the procedure is exactly the same as before; if it is resistance coupled the procedure is as follows, and it should be noted that this applies to any resistance-coupled stage and not merely to the precise arrangement of Fig. 17.

The first step is to remove the preceding valve (V₂) and to short-circuit the R.F. choke (CH₁), if any. If hum be present, disconnect the coupling condenser (C₈) from the coupling resistance (R₇). If this removes the hum it is undoubtedly due to the H.T. supply to V₂ and a defect in the smoothing or decoupling circuit is indicated. The condensers should be checked, but if there is no defective component, an increase in smoothing or decoupling capacity is needed; an increase in the decoupling condenser (C₇) will usually be satisfactory.

The R.C. Coupled Stage

Should the hum be present with the coupling condenser (C₈) disconnected, however, it is being picked-up on the grid and grid circuit components of V₃ from the electric hum-field rather than the magnetic. A reduction in the value of R₉ will usually help, but this will reduce the bass response unless accompanied by a proportionate increase in the capacity of the coupling condenser C₈. For a given bass response, the actual values of coupling condenser and grid leak are unimportant, and it is only necessary that their product should be constant. A reduction in R₉, however, will reduce the amplification somewhat, so one cannot go far in this direction. The true remedy for hum pick-up of this kind is screening. A metallized valve should be used, the grid leads made as short as possible,

TRACING MAINS HUM

and run in screened sleeving if they are more than an inch or so long.

When hum has been eliminated the preceding valve can be replaced and its input circuit short-circuited. Any hum which now occurs can be due only to the valve or its bias supply, if any, and the procedure for removing this has already been given. When silence has once again been obtained, remove the short-circuit from the R.F. choke, if

there is one ; if this introduces hum it is being picked up by the choke. One remedy is to orient the choke to the position of minimum hum, just as in the case of an A.F. transformer, but it need not, of course, be disconnected. The alternative is to replace it by an astatically wound choke, such as a binocular choke.

The next step is to remove the short-circuit from the input and treat the preceding stage in the same manner, if it is another A.F. stage. If this valve is a grid detector, however, and transformer coupling is used between it and the preceding valve as in Fig. 24, any hum now introduced can only be picked-up on the detector grid from the electric field, for which the remedies have already been given, or pick-up by the tuning coil from the mains transformer. This last is only likely if the coil is of very large diameter, or is an I.F. transformer having high inductance coils : even then, it is only likely if the coil is mounted right alongside the mains transformer.

When tuned anode coupling is used, however, as in Fig. 17, a ripple on the H.T. supply to the R.F. valve may cause serious hum, for an appreciable proportion of it will be passed straight to the detector grid in spite of the small size of the coupling condenser C_4 . The remedy, of course, is to increase the smoothing of the H.T. supply to this valve, or to look for a defect in the smoothing system.

It should be noted that this type of hum is quite probable,

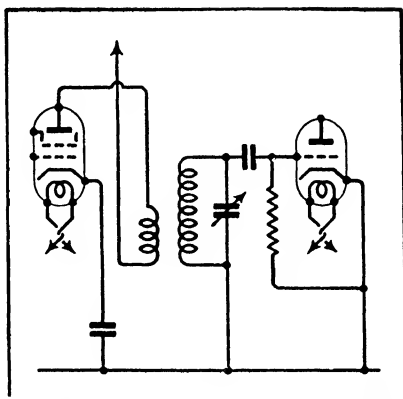

Fig. 24 : The method of connecting an R.F. transformer before a grid detector

WIRELESS SERVICING MANUAL

for the anode voltage of the R.F. valve is often less well smoothed than that of the detector, since the supplies are taken from the same point on the H.T. supply system, and less decoupling is used in the R.F. stage. This particular variety of hum does not occur with the tuned grid circuit any more than it does with transformer coupling, but the ripple may cause trouble in other ways.

The testing procedure outlined in the foregoing will, if faithfully followed, reveal the cause of any hum of the type which is continually present whether the receiver be tuned to a signal or not. It is, however, rarely necessary to go through the whole procedure, and indeed it would be unutterably tedious to do so. The full process is necessary only when every type of hum is simultaneously present, and it would be a very exceptional set in which this occurred.

It is not uncommon for a set to have several sources of hum, but their location is not usually a difficult or a lengthy business. Hum is, of course, more likely to occur in a newly-constructed receiver than as the result of a breakdown, except in the matter of valves. It may often be necessary to remove it from old sets, however, for many of these gave appreciable hum which, though tolerable at the time, would not be so to-day.

Localising the Trouble

The short-cuts to testing consist of a few rapid tests which localise the source of the trouble to one portion of the receiver. If a receiver is arranged to operate with a pick-up, for instance, the first step is to short the pick-up terminals and turn the control switch to gramophone. If the hum ceases, one knows at once that the circuits following the pick-up switch are in order and that it is a waste of time to investigate them; it should be pointed out, however, that this test does not necessarily absolve the grid circuit of the valve to which the pick-up is connected. Should the hum continue unabated, it is obviously occurring in a later circuit.

As an example of the method of rapid testing, suppose that a receiver of the type of Fig. 17 is giving trouble from hum. The first thing is to short-circuit the A.F. transformer secondary. If there is hum, investigate the speaker field, and if that fails, the output stage itself. If the hum ceases, however, one knows at once that the output stage and field supply are in order, and the next step is to remove the short-circuit from the transformer secondary and apply it to the input of V₃. Suppose this reduces the hum, but does not completely remove it. It is

TRACING MAINS HUM

clear that some of the hum is occurring in this stage and some at an earlier point. The A.F. transformer should be tested for hum pick-up and if this fails, the H.T. supply and valve. When this particular source of hum has been removed, and not before, the short on the input can be removed and transferred to the preceding stage. The remaining hum is in the extra stage now in circuit and a few tests on the lines described will speedily reveal its source.

Gramophone Hum

In the case of gramophone equipment, there are additional sources of hum ; the pick-up itself and the leads to it. Little extra testing is needed, however, for the pick-up leads should invariably be screened, and if the pick-up itself appears responsible for the hum the real cause is usually a faulty or badly-designed motor. Care should, of course, be taken to see that the motor frame is earthed and that the insulation of the motor windings from the frame is satisfactory. A dirty commutator will cause serious noise which can hardly be described as hum, but excessive vibration may lead to hum as soon as the pick-up is placed on the record.

Before leaving the question of direct mains hum, it may be as well to point out one or two ways of increasing the smoothing with little additional apparatus. In an A.C. set, the hum is of definite frequencies, and where one frequency predominates it is possible to reduce it greatly by using a tuned smoothing circuit.

Where full-wave rectification is used, the chief hum frequency is twice the mains frequency, or 100 c/s in the case of 50 c/s mains. If one of the smoothing chokes is shunted by a condenser of the correct value it will resonate at 100 c/s and very greatly reduce the hum. When the inductance of the choke is known the condenser capacity can readily be calculated ; it is given by $C = 1/\omega^2L$ where C is the capacity in farads, L is the inductance in henrys, and $\omega = 6.28 \times \text{frequency}$. Thus, to tune a 10 H. choke to 100 c/s, the capacity must be $0.254 \mu\text{F}$.

Tuned Smoothing System

There is one grave disadvantage about this arrangement which renders it of only occasional use ;—although it greatly increases the smoothing at the resonant frequency, it reduces it at other frequencies. The chief hum frequency is 100 c/s, but there are also frequencies of 150 c/s, 200 c/s, 250 c/s, and

WIRELESS SERVICING MANUAL

so on, and although they may be weaker, both the loudspeaker and the ear respond to them more readily. Thus, while tuning a choke may remove 100 c/s hum, it may introduce hum of higher frequency, so that one is no better off. There are, however, occasions where the system is of benefit.

When half-wave rectification is used, as in most Universal receivers, the chief hum frequency is at the mains frequency, usually 50 c/s, but there are multiples of this frequency. It is definitely dangerous to use tuned smoothing chokes in such sets, even if they prove advantageous on A.C. The hum frequencies with D.C. mains are usually quite high, and a tuned smoothing system which is suitable for A.C. will offer little barrier to the ripple on a D.C. supply.

Tracing hum in D.C. and A.C./D.C. sets is much the same as in a purely A.C. set. It is rendered more difficult by the fact that one cannot remove valves while testing since their heaters are wired in series, but to compensate for this there is no mains transformer from which other components can pick up hum. The chief difficulties are likely to be found in cases where the positive side of the mains is earthed, and in contradistinction to the usual case with A.C., where a good earth is an advantage and sometimes an essential, better results are often secured without any earth connection at all.

One of the main troubles with D.C. supplies is that the same remedies do not apply in different cases. Hum troubles in the set itself, of course, respond to the usual tests just as in the case of an A.C. set, but one can never be certain that the manner in which the set is used will not cause trouble. It is unfortunately necessary to treat each case on its merits and one can never guarantee that a D.C. set, however well it may be designed, will be hum-free on all supplies. It is largely for this reason that set designers have such an aversion to D.C. receivers.

In connection with the use of a gramophone pick-up with A.C./D.C. and D.C. sets, it may be remarked that in certain cases it is disadvantageous to employ earthed screening for pick-up and other connections. Indeed, such screening may lead to more hum than unscreened leads. Screening is, of course, necessary for the avoidance of hum, but experience indicates that it must not be earthed, but maintained at the same potential as negative H.T.

It cannot be connected directly to negative H.T., however, for screened leads are usually in accessible positions and there would be a serious risk of shock or fire if they were in direct

TRACING MAINS HUM

connection with the supply mains. The best course is consequently to connect all such screening to negative H.T. through an isolating condenser which should not exceed $0.01 \mu\text{F}$ for A.C. supplies and which should be rated for working at 300 volts.

Modulation Hum

Some of the most difficult forms of hum to trace appear only when a signal is tuned in, and in the absence of a carrier the receiver may be quite silent. Such hum arises because for some reason the hum voltages modulate the carrier of the station to which the receiver is tuned, and it is consequently generally known as modulation hum. A ripple on the H.T. supply to an R.F. or I.F. valve, for instance, may cause modulation hum whatever the nature of the intervalve coupling. In the case of tuned anode coupling, a ripple on the supply to the last R.F. valve will cause direct hum, as already pointed out, but it will not cause such hum with transformer or tuned grid coupling. The hum may be impressed upon the carrier of a signal, however, for the anode voltage of the valve will fluctuate at the hum frequency, and unless the valve be perfectly linear its amplification will vary in sympathy. Consequently, the carrier voltage at the detector will be varying in amplitude at the hum frequency; in other words, the carrier will be modulated by the hum.

Testing for Modulation Hum

The liability of a receiver to such hum is most readily tested by connecting the output of an oscillator to the input of the last R.F. or I.F. stage and tuning it to the appropriate frequency. The oscillator should be unmodulated, otherwise any hum will be obscured. The oscillator output should be increased until hum appears.

If the input is judged to be larger than any signal input likely to be applied to this valve under normal operating conditions, nothing need be done, for the appearance of the hum is due chiefly to the valve being overloaded and the ripple on the H.T. supply is small. If the hum is prominent with a normal input, however, the ripple is excessive and more smoothing of the anode or screen supplies is indicated; the stage is incorrectly designed and cannot handle the input without overloading, so that the anode and screen voltages should be raised; or the stage is overloaded through the deterioration of the valve.

WIRELESS SERVICING MANUAL

By transferring the test oscillator stage by stage towards the aerial, each stage can be tested individually for modulation hum. In a receiver which has previously functioned satisfactorily, the only likely causes are faulty valves, both in emission and in heater-cathode insulation, and defective smoothing or decoupling equipment.

The commonest cause of modulation hum, however, cannot be found in this way. The hum appears usually only when the receiver is tuned to the local station, and while such hum may be due to overloading of an R.F. or I.F. valve, it is more commonly caused by R.F. currents in the supply mains. Such hum does not appear in A.C. sets which have a screened primary mains transformer, provided that other coupling between the mains and the receiver circuits is absent. The first step should be to make sure that the screen is properly earthed; if it is, and it is found that reversing the mains plug in its socket alters the degree of hum, the trouble is almost certainly due to the wiring to the on-off switch. Screening the wiring to this switch may effect a cure, but it is better to fit a new switch well removed from the receiver circuits. The usual switch attached to the volume control is in a particularly dangerous position from the point of view of mains hum, for the mains leads must necessarily pass through much of the receiver wiring.

In cases where the primary of the mains transformers is not screened, it is obviously impracticable to attempt to introduce screening and an alternative remedy must be found. A complete cure will usually result from the connection of condensers

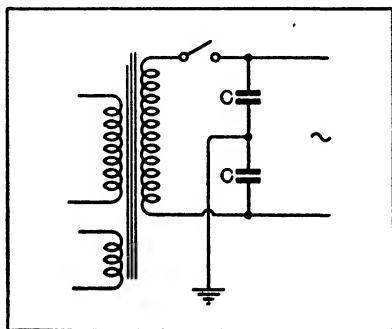

Fig. 25 : The connection of condensers C between mains and earth is an effective remedy for modulation hum

between the mains and earth, as shown in Fig. 25; the value used for these condensers C is not critical, and $0.0001 \mu\text{F}$ is usually quite large enough. The condensers should, however, be rated for 250 volts A.C. working.

Moving the Receiver

When obstinate cases of modulation hum are found, it is always

TRACING MAINS HUM

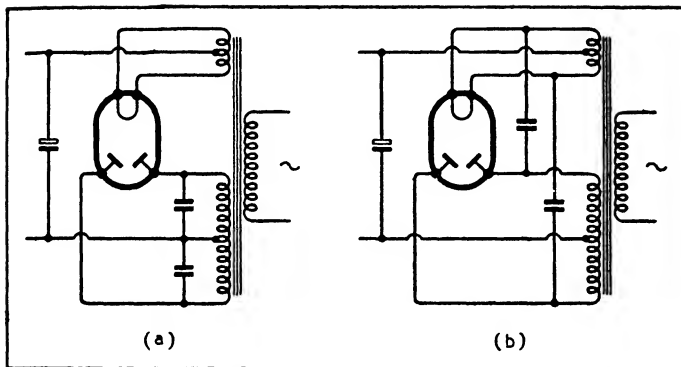

Fig. 26 : Condensers across the high-voltage winding of the mains transformer are helpful when the rectifier is responsible for hum

worth while to try operating the receiver somewhere else. The house wiring is carried out in ceilings, floors and walls, and it may occasionally happen that the receiver is used in such a position that it is almost surrounded by concealed house wiring and so may be in quite a strong hum field. Similarly, the aerial lead-in may pass through such a field and so lead to difficulty.

It is possible for the rectifier to give rise to modulation hum in certain circumstances, although it is not very common. The connection of condensers *C* as in Fig. 26 will usually cure trouble of this nature and $0.1 \mu\text{F}$ is the usual value. The condensers must, however, be of very high voltage rating; in the case of Fig. 26 (a) for one-half the total A.C. voltage of the H.T. secondary, that is, 350 volts A.C. working for a 350-0-350 volts winding, or nearly 500 volts peak. With the arrangement (b), however, even higher voltages are encountered, for the voltage on the condenser is the sum of one-half the total A.C. voltage and the rectified D.C. voltage. As the latter may be nearly equal to the peak A.C. voltage when the set is first switched on, the condensers should for safety be rated for operation at the total A.C. voltage of the high voltage winding, that is, 700 volts R.M.S. or 1,000 volts peak, for a 350-0-350 volts transformer.

With D.C. and A.C./D.C. receivers, modulation hum can again be caused by R.F. currents in the supply mains and its

WIRELESS SERVICING MANUAL

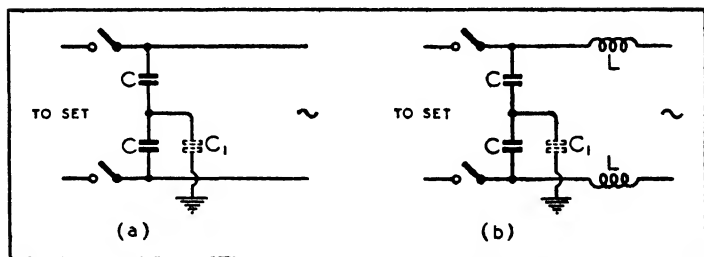

Fig. 27 : In D.C. and Universal sets, a simple mains filter may be needed to prevent modulation hum. The condenser C_1 is needed only when it is necessary to use large capacities for C , and it should be of some $0.001 \mu\text{F}$ capacity

elimination is much more difficult, for there is no mains transformer to give any isolation. The remedy, of course, is to insert a filter in the mains leads, and in some cases condensers to earth as in Fig. 27 (a) suffice ; for D.C. only the condensers C should be about $0.5/1 \mu\text{F}$, but for A.C. it is inadvisable to make them larger than $0.1 \mu\text{F}$. If large condensers are necessary, then it is wise to insert C_1 of $0.001 \mu\text{F}$ to $0.1 \mu\text{F}$ in the earthing lead. It will often be necessary to include R.F. chokes in the mains leads as well as these condensers. They must be wound with heavy-gauge wire, No. 22 or heavier ; suitable chokes for the medium waveband can be made by winding 60 to 100 turns of No. 22 D.C.C. as a single layer on a 2-in. diameter former. Fortunately, coupling between the two chokes seems to have no adverse effect, but they should, of course, be kept as far as possible from the receiver circuits.

It is rare for the heater supply to introduce hum in purely A.C. sets, except on the short wavelengths where modulation hum may be experienced. In general, such hum can be cured by connecting by-pass condensers to earth from the heater of the offending valve. The trouble usually arises in the oscillator circuit, and $0.01 \mu\text{F}$ mica or ceramic dielectric condensers are to be recommended for the purpose. In A.C./D.C. sets, the order in which the heaters are wired is of importance, but there is rarely any difficulty if the detector be placed at the earthy end of the chain.

CHAPTER 6

MOTOR-BOATING

THE name of "motor-boating" is usually given to that form of instability which manifests itself by producing a noise which is not unlike that of a petrol engine. It is self-oscillation of very low frequency; the frequency is rarely higher than 25 c/s and is sometimes lower than 1 c/s; it usually lies about 2-5 c/s. Such extremely low frequencies are not, of course, directly audible, but the amplitude of oscillation is so great that the loudspeaker, and indeed the valves, are badly overloaded, with the result that higher frequencies within the audible range are present.

It is better to think of motor-boating as producing periodic pulses of current or voltage than as generating an oscillation in the common sense of the word. The amplitude reached is often sufficient for the movement of the loudspeaker cone to be readily visible, and if prolonged, it may damage the cone suspension.

There are three distinct forms of motor-boating, and it is necessary to distinguish them carefully if a remedy is to be found easily. The three forms are (a) pure A.F. feed-back, (b) R.F. instability, (c) modulation by A.F. feed-back. The first is the most common and the easiest to deal with. It invariably occurs through common impedance coupling, and the impedance is usually that of the H.T. supply, although it may occasionally occur from the source of grid bias. It is a fault which in normal circumstances only occurs in sets deriving their H.T. supply from a source other than batteries.

It is easy to see that the impedance of the H.T. supply is included in the anode circuits of all valves. Referring to Fig. 28, the impedance of the H.T. supply at low frequencies is clearly fairly high, since it consists of the output impedance of the smoothing equipment. This will vary greatly with frequency, and from receiver to receiver, but cannot be small unless the last condenser C be impracticably large.

Obviously, therefore, the A.C. output of the last valve will set up a voltage across it which will be communicated directly to the preceding stage and so cause regeneration or degeneration according to the phase of the feedback. If the phase be correct for regeneration, the bass response of the receiver will be increased, and if the feed-back be sufficient, motor-boating will occur. If the phase be such as to produce degeneration, there

WIRELESS SERVICING MANUAL

will be no motor-boating but the bass response of the apparatus will be seriously reduced. The common expedient of curing motor-boating by reversing the connections to the winding of an A.F. transformer must be considered bad practice, therefore, since by changing the phase relationships it merely converts excessive regeneration into degeneration and does nothing to prevent the feed-back.

The correct remedy for motor-boating is to introduce adequate decoupling. Each A.F. stage except the last should have its anode circuit decoupled by the usual resistance-condenser combination. The addition of such decoupling to the circuit of Fig. 28 is shown in Fig. 29, in which R_1 is the decoupling resistance and C_1 the decoupling condenser.

It can be seen that the resistance and condenser really constitute a simple filter circuit and they actually contribute greatly to the smoothing of the H.T. supply and so to the elimination of mains hum. The degree of decoupling obtained increases with the values assigned to the components, and is roughly proportional to the product of resistance and capacity. The amount of decoupling required depends upon the degree of amplification between the point which must be decoupled and the anode circuit of the last valve, upon the frequency

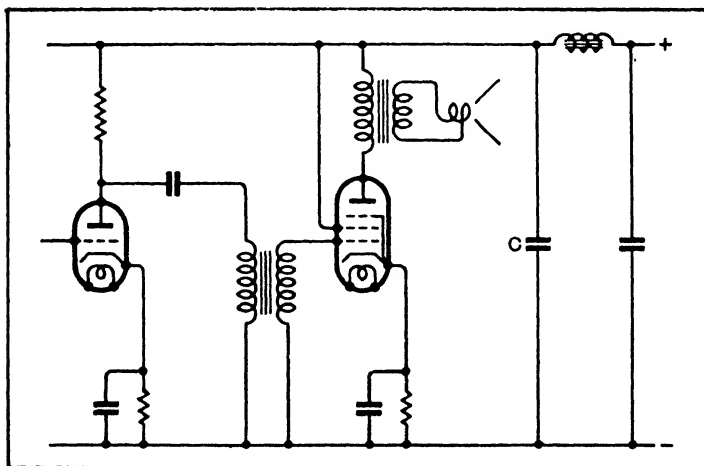

Fig. 28 : A typical A.F. amplifier illustrating the way in which feed-back occurs

MOTOR-BOATING

response characteristic of the amplifier, and upon the impedance of the H.T. supply. It is consequently impossible to give any general ruling for circuit values.

Value of R C

Experience shows, however, that the RC product should not be less than about 80,000 (R in ohms, C in microfarads) in an arrangement such as that of Fig. 29 when the bass response is good. If an additional A.F. stage were used, the RC product for the first stage should not be less than 200,000, but that for the second stage can still be 80,000. The value of the resistance will naturally be as high as possible, since a high value resistance costs no more than one of low value, whereas the price of condensers increases with capacity. The resistance value, however, is limited by the permissible voltage drop across it, and this, of course, depends upon the anode voltage required by the valve and the H.T. supply available.

In a circuit such as that of Fig. 29, R_1 is commonly about 20,000 ohms and C_1 should then be some $4 \mu\text{F}$. In an earlier stage, the valve does not usually need such a high anode voltage and the decoupling resistance can then often be made as high

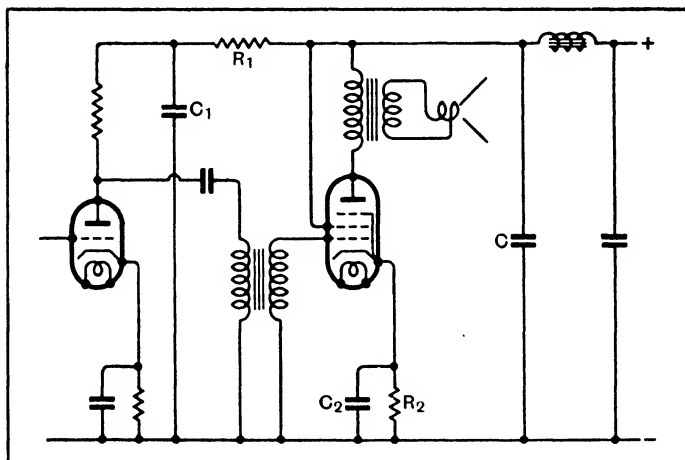

Fig. 29 : The decoupling components R_1 and C_1 are included to prevent feedback effects

WIRELESS SERVICING MANUAL

as 50,000 ohms. The capacity of the condenser can then be selected to provide the requisite decoupling, and it is seldom that anything higher than $8 \mu\text{F}$ is needed.

The use of a choke instead of a resistance for decoupling is sometimes recommended and it has the advantage that the voltage drop across it can be very small indeed. It is much more expensive, however, and in the author's experience not very effective. To do any real good the choke should have an inductance of several thousand henrys and this is obviously out of the question. Moreover, there is a risk of resonance effects occurring whereby the feed-back is increased by such a "decoupling" circuit.

In the case of grid circuits, when cathode bias is used, feed-back may occur from the anode to the grid circuit of the same valve. Such feed-back is degenerative and does not cause motor-boating, but reduces the stage gain. If the by-pass condenser (C_2 , Fig. 29) is absent, there is little harm in the feed-back beyond the loss of amplification, but if the condenser is present but of too small capacity, there will be a reduction in the bass response only.

To be effective the by-pass capacity must be very large, and it is a safe rule to choose a condenser having a reactance at the lowest important frequency of not more than one-tenth of the value of the bias resistance. Thus if R_2 is 1,000 ohms, C_2 should have a reactance of about 100 ohms at the lowest frequency considered important, usually 50 c/s. The nearest standard value is $25 \mu\text{F}$, which has a reactance of 127.2 ohms at this frequency.

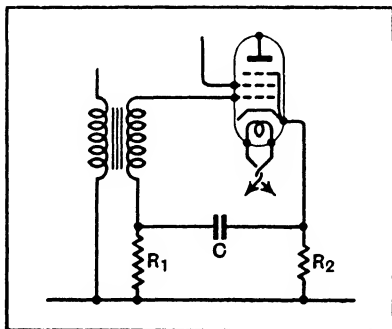

Fig. 30: The grid circuit of a transformer-coupled stage can be decoupled by C and R_1

Capacities of this order are quite practicable, for in most cases the voltage drop across R_2 does not exceed 40 volts or so and may be much less. Electrolytic condensers of $50 \mu\text{F}$ rated for working at 50 volts are quite reasonably priced and entirely suitable for use in such circuits. For voltages up to about 12 volts, $200 \mu\text{F}$ condensers are obtainable.

MOTOR-BOATING

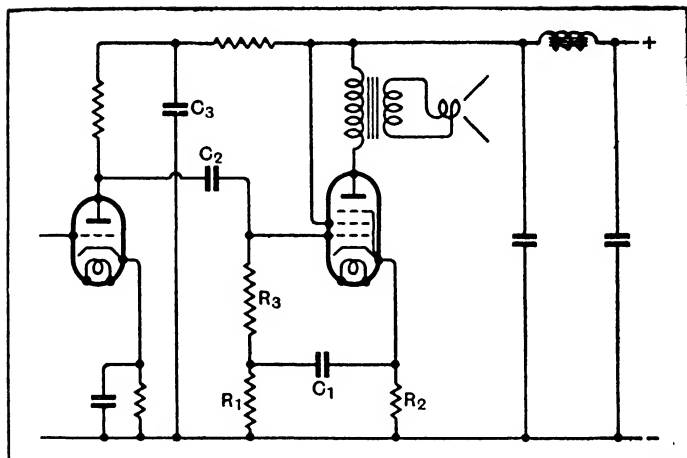

Fig. 31 : Grid circuit decoupling is ineffective with resistance coupling

An alternative arrangement possible in some cases is to adopt grid circuit decoupling as shown in Fig. 30. The bias resistance is R₂ and A.C. potentials developed across it are prevented from reaching the grid by the decoupling system R₁ C. The values are in no way critical and it is nearly always satisfactory to give R₁ a value of 100,000 ohms and C a capacity of 1 μ F. It is important to remember that C must *not* be an electrolytic condenser. There is always some leakage in an electrolytic condenser, and in this instance it would have the effect of very appreciably reducing the grid bias actually applied to the valve.

It should be remembered also that when cathode bias is used, grid decoupling is only effective when the intervalve coupling is by means of a transformer; it is useless to employ it with resistance or auto-transformer coupling. This is clearly seen from Fig. 31; although potentials developed across R₂ are prevented by the decoupling components R₁ C₁, from reaching the grid of the valve through the grid leak R₃, they can easily reach the valve through the alternative path provided by the anode circuit decoupling condenser C₃ of the previous valve and the intervalve coupling condenser C₂.

In such cases there is no alternative to the use of a large

WIRELESS SERVICING MANUAL

capacity bias resistance by-pass condenser as long as cathode bias is retained, and for A.F. stages in general it is usually the best system. When grid bias is obtained by means of a resistance in the main H.T. negative lead which is common to all valves, however, grid circuit decoupling can be employed whatever the nature of the intervalve coupling; in fact, it really demands this form of circuit isolation. In general, however, cathode bias is better, for each valve is then independent of the others for its grid bias.

When resistance coupling is used, the feed-back caused by the common impedance of the H.T. supply is positive and negative on alternate stages. In general, phase shifts in the couplings prevent one from making use of this fact to reduce the decoupling needed, except in the penultimate stage. Here it is not uncommon to find decoupling omitted.

Its omission not only results in a saving of components but enables a somewhat greater undistorted output to be obtained from the valve, since the voltage drop across a decoupling resistance is avoided. The disadvantages are the loss of the smoothing effect of a decoupling circuit and some reduction of bass response at very low frequencies. This last can be of negligible importance, for it is not difficult to push below audibility the frequency at which the response begins to drop.

With resistance coupling between the penultimate and output stages, the inclusion of decoupling at this point does not help to reduce motor-boating. If the penultimate valve is a pentode, however, feed-back to its screen, but not its anode, is regenerative, so that screen decoupling is important. A pentode A.F. stage usually has very high resistance values and quite small capacities consequently give adequate decoupling. A screen-feed resistance, for instance, is often about 0.3 megohm, and a capacity of 0.2 μF or so is then sufficient.

There is little which need be said about the methods of tracing A.F. feed-back, for its appearance in a set is invariably due to inadequate decoupling. If the set has previously functioned satisfactorily the trouble will almost certainly be due to an open-circuited condenser or short-circuited resistance. The latter is easily found by checking the resistance values or measuring the voltage drop across the resistance. The former can, of course, be checked by measuring the capacity of the condensers concerned, but it is usually easier to keep a spare 4 μF paper condenser, fitted with flex leads terminating in crocodile clips, and connect it in parallel with each condenser in turn. Do not forget to discharge the condenser after it has

MOTOR-BOATING

been used and never discharge it by short-circuiting it, for this may damage the condenser. Always discharge a condenser gradually through a resistance of at least 10,000 ohms.

R.F. Instability and Motor-Boating

Turning now to the second type of motor-boating, caused by R.F. instability, this normally occurs only in sets fitted with A.V.C. and the action is as follows:—Self-oscillation results in a large detector input from the locally generated oscillations and this means that the A.V.C. circuit biases the controlled valves negatively by quite a large amount. The instability consequently ceases, the detector input falls and the A.V.C. bias drops to zero. Oscillation then recommences and the whole cycle of events is repeated indefinitely.

The audible result is practically indistinguishable from true motor-boating, the frequency being determined by the time constant of the A.V.C. system. The remedy, of course, is entirely different and for the procedure to be adopted reference should be made to the chapter dealing with R.F. instability. It is usually possible to distinguish this form of motor-boating from that due to true A.F. feed-back because it will disappear when the set is tuned to a strong signal, for A.V.C. will then bias back the controlled valves and make the set stable.

The third type of motor-boating is usually apparent only when a strong signal is tuned in. It is due to A.F. feed-back to the anode or screen circuit of one of the R.F. or I.F. valves. Continuous motor-boating cannot occur, for the couplings will not pass low frequencies, but when a carrier is present the low-frequency potentials fed back can modulate it, and they then pass through the couplings as a modulation on the carrier. Modulation demands non-linearity in one of the valves, so that two remedies are available—to prevent the feed-back or to remove the non-linearity. The latter may be impossible, however, for the non-linearity may actually be caused by the feed-back if this is great.

Modulation by A.F. Feedback

It is clear, therefore, that for the avoidance of this effect the anode and screen circuits of R.F. and I.F. valves should be thoroughly decoupled, and values chosen for the decoupling components which are effective at low frequencies. This is not always easy, for the voltage and current requirements of many R.F. type valves prohibit the use of high value decoupling

WIRELESS SERVICING MANUAL

resistances. Resistances of only a few thousand ohms are of little use unless the decoupling condensers are of the order of $50 \mu\text{F}$, and these are rather expensive in high voltage ratings.

Fortunately, the trouble is one which occurs quite rarely in practice. It is usually present only when an exceptionally good A.F. amplifier is used having a very good bass response. The best remedy, and probably the cheapest in the long run, is to use separate H.T. equipment for the post- and pre-detector stages, but with care it is possible to overcome it by modifying the A.F. couplings so that there is a cut-off below about 25 c/s. This affects quality to a negligible degree. The use of a well-balanced push-pull output stage greatly reduces any tendency to this form of motor-boating. When it occurs in a set fitted with push-pull A.F. amplification, therefore, a very probable cause is that the amplifier is imperfectly balanced at the lowest frequencies.

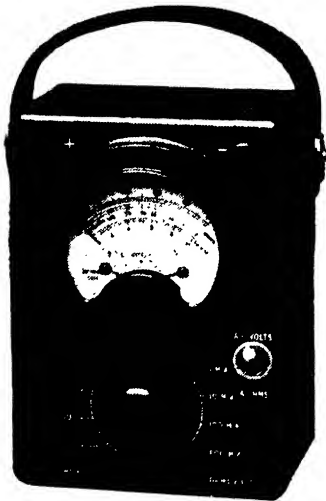

British Physical Laboratories Universal Test Set provides A.C. and D.C. voltage ranges as well as resistance and direct-current measurements

CHAPTER 7

INSTABILITY IN R.F. AND I.F. STAGES

ONE of the commonest troubles encountered in a receiver, whether new or old, is instability in the R.F. or I.F. amplifier. It is invariably due to the presence of unwanted coupling between circuits separated by one or more valves and the search for a cure inevitably means tracing the coupling. Unwanted couplings may be due to a common impedance; they may be electro-magnetic between coils and wiring; or they may be electric, between components and wiring, and in the valves themselves.

It cannot be too strongly emphasized that when instability is present there *must* be an amount of coupling between different circuits which is excessive for the degree of amplification. Since it is always impossible completely to eliminate stray couplings, there is an upper limit to the amplification obtainable with stability. This may seem a truism, but it is all too often overlooked.

In the case of instability in a straight set or in the signal-frequency amplifier of a superheterodyne, much useful information can be gained from the manner in which the performance varies over the waveband. It will usually be found that the instability occurs chiefly at the high frequency end of the

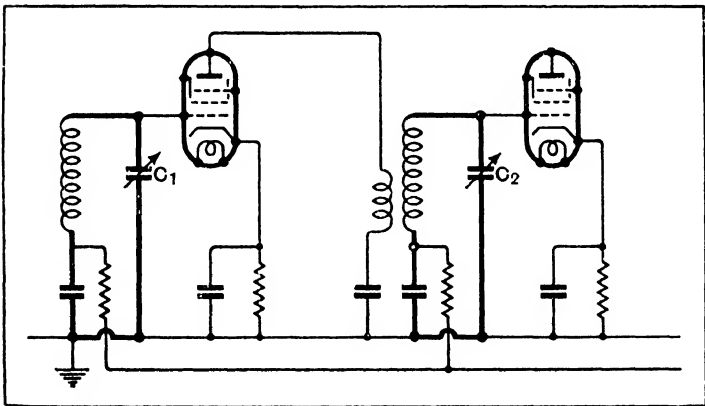

Fig. 32 : Each tuned circuit should be complete in itself as shown by the heavy leads

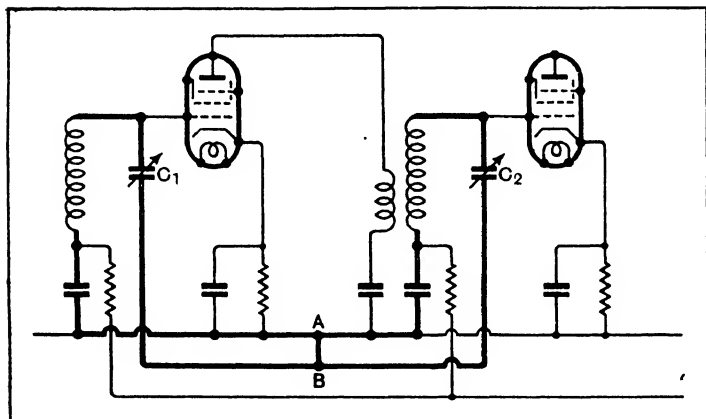

Fig. 33 : If the wiring be carried out so that any lead is common to two tuned circuits, instability is probable

waveband for two reasons :—first, the amplification is usually at its greatest at this end of the tuning range, and secondly, the coupling provided by stray capacities increases with frequency.

Sometimes, however, the reverse effect is obtained, and although a set may be quite stable at high frequencies, self-oscillation sets in which the tuning control is rotated to the low-frequency end of the waveband. The trouble is then invariably due to common impedance coupling and is usually quite easy to trace. A typical arrangement is shown in Fig. 32, and the way in which the tuned circuits are completed forms one of the greatest danger points.

Each tuned circuit as a whole is indicated by heavy lines and in the receiver the wiring completing each circuit should be quite distinct from that involved in any other. Now in a gang condenser, the rotors are all in connection with the frame, and it is a temptation to earth the frame at a single point only. If this be done the circuit becomes effectively that of Fig. 33 in which the lead marked AB represents the earthing lead of the gang condenser. It is clear that the resistance and inductance of this lead form an impedance which is common to both tuned circuits and which consequently couples them together. It might be thought that the impedance of such a lead, which rarely exceeds six inches or so in length, would be negligibly

INSTABILITY IN R.F. AND I.F. STAGES

small. This is not the case, however, and it is quite sufficient to cause severe instability in many cases.

When instability of this particular type is found, therefore, the first thing to do is to investigate the wiring of the tuned circuits to make sure that there are no common leads. In some receivers, the gang condenser is not earthed directly, but its contact with the chassis is relied upon for the connections to the frame. This is usually quite satisfactory provided that sound contact between condenser and chassis is obtained at several different points well spaced along the condenser.

The sudden appearance of instability in a receiver which has been previously working well can often be traced to a poor contact between condenser and chassis owing to one of the fixing bolts having become slack. An ohmmeter test of circuit resistance will not reveal a defect of this nature, for the D.C. circuit resistance will be a minute fraction of an ohm. In a similar manner, a common return lead to a decoupling condenser may cause instability, and it is a wise plan to wire a receiver in such a way that no lead is included in more than one circuit except where experiment shows that the use of a common connection causes no harm.

When the instability occurs at the high frequency end of the tuning range, however, it is rare for common impedance coupling to be responsible, and it is more usually caused by electromagnetic or electric coupling or both. The former is unlikely to appear in a receiver which has previously been satisfactory unless a poor connection has developed between a coil screen and the chassis. It is quite possible in a new set, however, even with apparently well-screened coils.

It is not always realised that screening is never perfect, and that the conventional coil screen merely reduces the external field of the coil to something like one-twentieth of what it would be without the screen. Of course, when coils are individually screened the coupling between them is reduced much more, the field inside the second screen due to the first coil being about $\frac{1}{20}$ of what it would be if neither coil were screened. These figures are very rough and depend greatly on the size of the screens and the

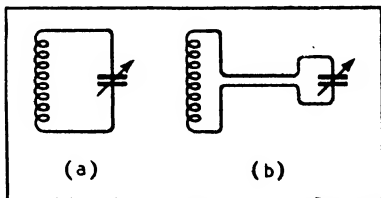

Fig. 34 : In order to reduce stray coupling, the connections in a tuned circuit should be kept close together

WIRELESS SERVICING MANUAL

material of which they are made as well as its thickness. They do show, however, that even with screened coils appreciable coupling may exist.

Stray electromagnetic coupling may also exist in the wiring if this be carried out in such a way that large loops are formed. This is particularly important in the case of tuned circuits. It is clear from Fig. 34 (a) that if the two leads between coil and condenser are widely spaced, there will be an appreciable field which will link with other circuits, whereas if the leads are run close together as in (b) no such field can exist, for the field surrounding each lead is cancelled by the equal and opposite field surrounding the other.

Capacity Couplings

In spite of the dangers of electromagnetic coupling, stray capacitive coupling is probably responsible for 90 per cent. of instability troubles. This can occur between any unscreened components or wires, and it is naturally most important when the difference of R.F. potential between the circuits is large. It is necessary, therefore, to keep the grid and anode leads of a valve well separated, and screening is usually needed. It is, however, much more important to keep the anode lead of the second stage away from the grid lead of the first, for as the amplification between these two points is much greater, the difference of R.F. potential is much larger and a smaller degree of coupling will promote instability.

Keep Grid Leads Short

In order to reduce any tendency towards instability, one is often advised to keep all grid leads as short as possible. The idea behind this piece of advice is that, as the valve amplifies, any feed-back to the grid circuit will be much more serious than in the case of the anode circuit. It is, however, a scheme which can be carried too far, for a little thought will show that the anode lead of the first R.F. stage is just as much a danger point as the grid lead of the second, their R.F. potentials being in many cases identical.

An endeavour to obtain very short grid leads often means abnormally long anode leads, with the result that one may actually be worse off than if longer grid leads were employed. In general, the most sensitive point is the grid lead of the first valve, and then the *aerial* lead. Next in order, and of equal importance, come the anode lead of the first valve and the grid lead of the second stage and so on through the receiver.

INSTABILITY IN R.F. AND I.F. STAGES

With a new and unstable receiver, stabilisation resolves itself into the removal of the stray couplings responsible for the unwanted feed-back. This is not easy unless a systematic method of progression be adopted, for degrees of instability are difficult to determine and there may often be several different kinds of feed-back present at the same time. Stability may be achieved by the removal or reduction of them all, but not by any one alone.

The best procedure is to modify the set in some way, so that it is only just unstable, even if this entails a big drop in amplification, for with the set in this condition the removal of any one source of feed-back is likely to stabilise the set, and each source of feed-back can be dealt with in turn. Thus, if a set be fitted with a manual volume control of the type operating by changing the grid bias of early stages, the set can readily be stabilised by its adjustment. Modern receivers fitted with A.V.C. do not normally include such a control, but it is usually a simple matter temporarily to wire a variable resistance of some 5,000 ohms in the cathode lead of one of the valves. The resistance should, of course, be shunted by a condenser of $0.1 \mu\text{F}$ capacity.

The procedure is to set the control at such a value that the set is only just oscillating, that is, so that the slightest increase in the resistance value causes oscillation to cease. Changes in the receiver can then be made and their effect upon stability instantly determined. The wiring should first receive attention and suspected leads can be moved with an insulated tool, such

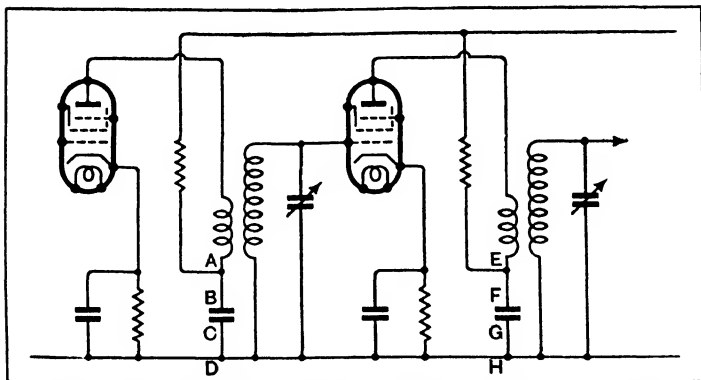

Fig 35 : Instability may occur through coupling between such apparently dead leads as AB and EF

WIRELESS SERVICING MANUAL

as a wooden pencil ; if the oscillation ceases on changing the position of any wire, then it is obvious that the wire in question is responsible for at least some of the feed-back. Its position should be changed to one which is less dangerous or it should be screened.

It is important to remember that so-called low-potential leads can be nearly as dangerous as grid and anode wiring. Referring to Fig. 35, it can be seen that for R.F. currents the anode circuit of each valve comprises the lead from the valve anode to the transformer primary, the transformer primary itself, the lead from it to the decoupling condenser, and the wiring between this component and the valve cathode. R.F. currents flow through the whole of this path, and are no stronger in any one part than in any other. Electromagnetic coupling may thus occur between any part of the primary circuit of one valve and any part of another. In particular, if the leads AB or CD in Fig. 35 run close to and parallel with EF or GH, instability is highly probable, although these are commonly believed to be "dead" wires.

Sources of Instability

When locating sources of instability it is necessary to try each possible source in turn. The wiring is often responsible, but inadequate decoupling of anode, grid, and screen-grid circuits is commonly to blame. The anode circuits are usually the most important and decoupling is generally necessary when the receiver includes more than one R.F. or I.F. stage. The grid circuits are next in importance and the screen circuits the least likely to cause trouble. Decoupling of the screen circuits is, in fact, usually unnecessary, and a simple by-pass condenser often suffices. It is, however, always necessary to make sure that the component used is in truth a condenser, for faulty components are not unknown and an internal open-circuit can be responsible for many obscure defects.

By-pass and decoupling condensers in R.F. or I.F. circuits usually have a capacity of $0.1 \mu\text{F}$, except in cases where decoupling must also be effective at low frequencies when the capacity may be as high as $2-8 \mu\text{F}$. Decoupling resistances vary much more ; where the aim is decoupling at R.F. only, values of $500-1,000$ ohms are common, but where A.F. decoupling is also considered the resistance may be $20,000$ ohms in anode circuits and $20,000$ ohms to 2 megohms in grid circuits, the high values being used in sets fitted with A.V.C. In many cases, however, the resistance is chosen to give the correct

INSTABILITY IN R.F. AND I.F. STAGES

anode voltage to the valve concerned, since its value is in no way critical from the point of view of decoupling.

Feedback from the A.F. Circuits

Apart from defects in the purely R.F. circuits which can lead to instability, the A.F. side of the receiver is often of considerable importance. The detector should ideally be fed with an R.F. or I.F. input and produce an A.F. output only. In practice, it always gives an R.F. output as well as the wanted A.F. voltages. Most receivers include a filter in the detector output circuit for the purpose of confining R.F. currents to the detector and of preventing them from being fed to the A.F. amplifier. Now it should never be forgotten that no filter can completely prevent the passage of the currents against which it is discriminating. However good the filter may be, there is always some leakage; in other words, the attenuation of any practical filter is never infinite.

The filter in many receivers consists merely of an R.F. choke and condenser as shown for a typical arrangement in Fig. 36. When a choke is used, it is usually the self-capacity which is of importance in the R.F. filtering and this may be as much as $3 \mu\mu\text{F}$ —allowing for stray wiring capacities. For frequencies higher than some 400 kc/s, the filter then reduces R.F. potentials to about 3 per cent. of what they would be in its absence; this is for a capacity C having the usual value of $0\cdot0001 \mu\text{F}$.

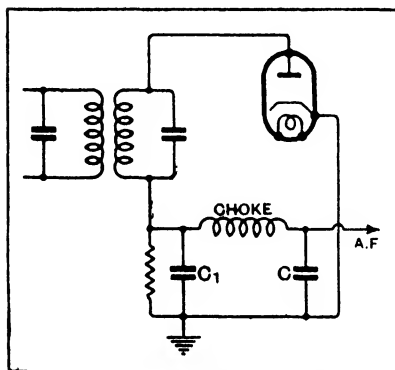

Fig. 36 : A typical filter in the output of a detector for preventing the leakage of R.F. or I.F. currents into the A.F. circuits

In many cases, the choke is replaced by a resistance of 50,000 ohms or so, and the condenser C usually has a capacity of $0\cdot0001 \mu\text{F}$ although it is sometimes as high as $0\cdot0005 \mu\text{F}$. At 465 kc/s, and using a resistance of 50,000 ohms, the reduction is to about 6-7 per cent. The resistance is nearly as good as the choke, and as it is cheaper it is often used.

WIRELESS SERVICING MANUAL

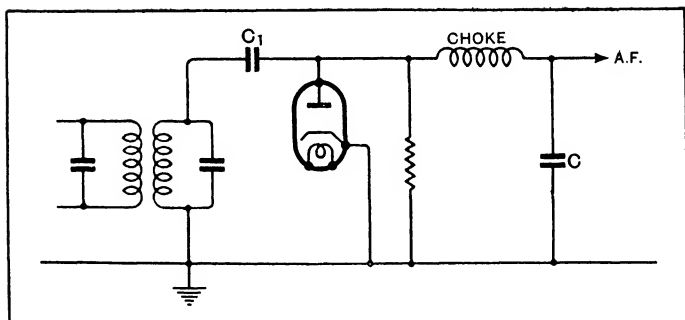

Fig. 37 : The R.F. filtering with this detector circuit is not as good as that with the arrangement of Fig. 38

It should be noted that the alternative arrangement of components shown in Fig. 37 is not nearly as good, for the R.F. input to the filter is very nearly the full voltage across the tuned circuit, whereas with the arrangement of Fig. 36 only the R.F. voltage set up across C_1 is applied to the filter. As regards the proportion of R.F. in the output, this circuit is about ten to twenty times as good as that of Fig. 37 ; the latter, however, can rarely be avoided in a straight set, for the tuning arrangements demand one side of the tuned circuit being earthed.

The method of Fig. 38 can, of course, be used in either straight set or superheterodyne, and it has all the advantages of the basic circuit of Fig. 36, being actually the same save for

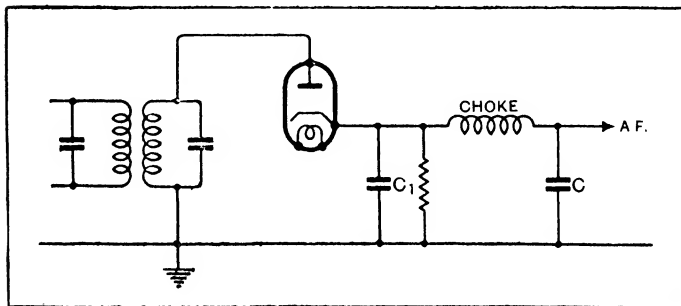

Fig. 38 : Even with a straight set, good R.F. filtering can be secured by adopting these connections

INSTABILITY IN R.F. AND I.F. STAGES

the point at which it is earthed and the point from which the A.F. output is taken. It is often inconvenient to be unable to earth the cathode of the valve, however, and it cannot be used in a battery set unless the diode be replaced by its equivalent, a metal rectifier, or one of the new indirectly heated duo-diodes is used.

Now it can be seen that with the degree of filtering commonly employed there is an appreciable R.F. or I.F. component in the output of the filter. Any coupling to early stages may consequently result in instability and this is particularly likely to be the case when the R.F. or I.F. frequency is low and resistance-coupled A.F. amplification is used. A good resistance coupled amplifier will give appreciable gain at 110 kc/s and it may pass to some extent frequencies as high as 465 kc/s. Unless the detector filtering be exceptionally good, therefore, R.F. or I.F. currents may appear in the output circuit of the A.F. amplifier in sufficient magnitude to cause instability if fed back to the input.

It is usually important, therefore, to keep the loud-speaker leads well away from the aerial and also from exposed parts of the receiver, while the aerial should not be permitted to pass close to the detector and A.F. circuits. It should not be thought that the necessity for these precautions, which amply demonstrates the presence of R.F. currents in the A.F. circuits, is evidence of bad design however. The steps necessary for almost perfect isolation of the circuits are well known but, unfortunately, impracticable in broadcast receivers. A well-designed multi-stage filter in the detector output circuits and separate complete screening of the R.F., detector, and A.F. stages is really necessary, but would make the equipment expensive and cumbersome.

Before concluding these remarks on instability, it may be as well to mention a few of the lesser known

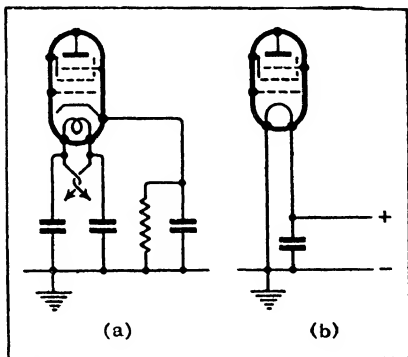

Fig. 39 : In A.C. sets (a) condensers from heater to chassis reduce couplings caused by the heater wiring, and in battery sets (b), a condenser across the valve filament has the same effect

WIRELESS SERVICING MANUAL

ways in which unwanted coupling may occur. It is well known that, to be effective, screening must be properly earthed ; it is not so generally known that if screening is not earthed it may in certain circumstances not only be inefficient as a screen, but actually introduce coupling. The heater and filament wiring of a set may also be responsible for instability and where this is suspected it is a good plan to connect by-pass condensers to earth as shown in Fig. 39. The condensers should be mounted as closely as possible to the valve concerned and have a value of about $0.1 \mu\text{F}$. In short-wave sets, however, $0.01 \mu\text{F}$ may be more effective.

Even in A.C. sets it is now common to find one side of the heater connected directly to the chassis as in a battery set, instead of isolating both sides and earthing a centre-tap on the heater supply. This rarely introduces hum, and has the great advantage of making the heater wiring much more nearly dead at radio-frequency. When it is adopted, condensers across the heaters are rarely needed, for the live heater lead is fairly well earthed to radio-frequency through the valve heaters themselves. They are sometimes necessary in short-wave equipment, however.

In general, condensers are less likely to be needed across valve heaters than across the filaments of battery valves. In an indirectly heated valve, the cathode and heater are separate, and the heater circuit only picks-up R.F. currents incidentally, but in a directly heated valve the filament is the cathode and necessarily carries R.F. current.

CHAPTER 8

FREQUENCY AND AMPLITUDE DISTORTION

THERE are two main types of distortion which may be encountered in receivers and amplifiers—frequency distortion and amplitude distortion. Both are always present to some degree, but in the highest grade apparatus they should not be detectable even when a direct comparison with the original can be made. Probably as much as 99 per cent. of the apparatus in use to-day, however, distorts to an appreciable degree.

The type of distortion most widespread is frequency distortion and it is fortunate that the ear can tolerate, and become accustomed to, quite a large amount, for interference-free reception of anything but the local station would otherwise be an impossibility. In the majority of receivers now sold frequency distortion is deliberately introduced in order to avoid interference, such as heterodyne whistles and sideband splash, for there is no known method of eliminating this type of interference without also removing the higher musical frequencies from the wanted transmission.

Ideally, the whole range of frequencies from 30 c/s to 15,000 c/s should be evenly reproduced. In practice, frequencies above 10,000 c/s are of little importance and it is possible to restrict the response to about 8,000 c/s before any really noticeable deterioration in quality takes place. If the cut-off occurs at a lower frequency than this, however, the change in quality becomes noticeable to all but the uncritical, and as the cut-off frequency is lowered the reproduction at first loses its brilliancy, then becomes lifeless, and finally muffled, so that speech loses much of its intelligibility.

Few sets, of course, give a sharp cut-off at their nominal upper limit of response and the falling-off at high frequencies is usually gradual. The majority of small superheterodynes do not give much output at frequencies higher than 4,000–5,000 c/s, and when the tone control is in operation there is very little output above 3,000 c/s, so that the reproduction can then be only a travesty of the original.

Such sets, however, in spite of their defects from an idealistic point of view, can give very acceptable results and most listeners are satisfied with the performance. Many, indeed, seem to prefer a severe cut in the top response, and it has often been a matter of wonder at the number of people who

WIRELESS SERVICING MANUAL

operate a set with the tone control permanently in the top-cut position when at its best the set is incapable of giving any real high-frequency response! The reason usually given for this is that such people are incapable of appreciating musical quality. The author does not agree with this, however, and in his view there is often justification for the extreme top-cut so often used. He believes that the tone control is "turned down" to reduce the *amplitude* distortion which is so often prevalent in the less expensive receivers. One result of amplitude distortion is to introduce harmonics, and as they are of higher frequency than the fundamental, they are reduced by cutting the treble response.

Three things combine to make the reproduction of many small receivers unsatisfactory. The first, and least important, is the sideband cutting in the I.F. amplifier, which restricts the response to about 4,000–5,000 c/s. The second is a large peak in the loud speaker response curve around 2,000–3,000 c/s. The third is the large amount of amplitude distortion introduced by the usual pentode output valve in conjunction with the usual small output transformer, and also by some A.V.C. systems.

A pentode is often operated to give 10 per cent. 3rd harmonic distortion at full output. At low frequencies it may well give more because the output transformer often has too small a primary inductance to maintain the load on the valve. The transformer itself can easily introduce 10 per cent. distortion, and again 3rd harmonic, at low frequencies. A low primary inductance can even result in a discontinuity in the valve dynamic characteristic at low frequencies; when this occurs very high order harmonics are generated.

The peak in the speaker response—which sometimes reaches 20 db.—accentuates the percentage harmonic distortion in the case of certain input frequencies. Thus, if the valve gives 2 per cent. distortion of a 1,000 c/s note, the 20 db. loud speaker peak at 3,000 c/s will bring the audible distortion up to 20 per cent. At 150 c/s too small a primary inductance in the transformer may result in a discontinuity in the characteristic. There might then be, say, 0.1 per cent. 20th harmonic generated. The speaker resonance would increase this to 1 per cent.—quite an appreciable amount for such a high order harmonic.

The audible effect of the combination of amplitude distortion and speaker resonance is to make the reproduction harsh, but apparently brilliant. Reducing the high-frequency response by the tone control partly offsets the effect of the speaker resonance, but at the expense of nearly all frequencies higher than the

FREQUENCY AND AMPLITUDE DISTORTION

resonance, and by doing so it reduces the amplitude distortion to the level of the valve and transformer alone.

The net effect is much smoother reproduction, and most people prefer it. This does not mean, however, that they do not appreciate a wide frequency response. It means merely that they object to amplitude distortion much more than they dislike the lack of the upper frequencies. The author has no doubt that the full range of musical frequencies would be appreciated if it could be obtained with a very low level of amplitude distortion, with an absence of marked loud speaker resonances, and without interference. Normally it is only in local reception that it is possible to obtain the full frequency response with freedom from interference, no matter how much one is prepared to spend on apparatus.

In a set for general purpose use, the dictates of selectivity limit the response to about 5,000 c/s. To make the best of this limited range, it is necessary to have well-designed I.F. circuits with a flat pass-band of some 10 kc/s and a very sharp cut-off. The loud speaker must be free from any marked resonances, and amplitude distortion must be kept to a very low level indeed. In some of the older receivers, the reproduction can often be greatly improved by fitting a more satisfactory loud speaker, changing the A.V.C. system to a type which does not cause amplitude distortion, and providing the output stage with negative feed-back. This last sometimes entails the addition of an extra A.F. stage.

These remarks must not be thought derogatory of the set designers. Technique continually advances and results can now be obtained which would have been impossible ten years ago. Then the designer nearly always has a limit of cost within which he must keep and do the best he can. The result is that it is nearly always possible to improve a set if one is prepared to spend money in doing so.

It is now necessary to consider those faults which may occur in a set through a breakdown in some component and which result in increased distortion. There are actually few which can cause a loss of the higher musical frequencies, although a short-circuit across the variable resistance of a tone control circuit would certainly do so. Short-circuited turns in an A.F. transformer may also affect the response at high frequencies, but will usually do so more noticeably at low frequencies.

The response at low frequencies is much more likely to be affected by defects which can develop in a receiver. An internal open-circuit in the coupling condenser of a resistance-coupled

WIRELESS SERVICING MANUAL

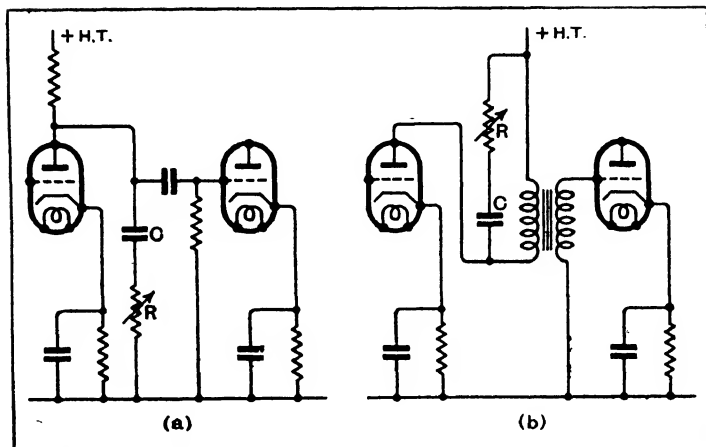

Fig. 40 : A tone control can readily be fitted to any receiver by connecting a variable resistance R and a condenser C across the coupling (a) or transformer primary (b)

stage, for instance, results not only in a large drop in volume but in a complete absence of the lower musical frequencies. Open-circuits in anode circuit decoupling condensers also affect the bass appreciably because feed-back is introduced. The effect may be either an increase or a decrease in bass, however, according to the phase of the feed-back.

An open-circuit in a bias resistance by-pass condenser does not usually affect the frequency response, but only causes a general drop in the amplification ; a reduction in the capacity of the condenser, however, will certainly cause the low frequencies to be attenuated.

As distinct from distortion which is a defect in a receiver, it is often desired deliberately to introduce frequency distortion of a particular kind in order to compensate for some defect or to make the reproduction more suited to the acoustics of a particular room. The ordinary tone control is one example of this nature, and as usually fitted it enables the upper frequency response to be reduced. If a receiver is not equipped with such a control, it is an easy matter to fit one by connecting the series combination of a variable resistance and a condenser across an A.F. coupling as shown in Fig. 40 for resistance coupling (a) and transformer coupling (b).

FREQUENCY AND AMPLITUDE DISTORTION

The values of the components depend not only upon the range of control required but also upon the impedance of the circuit across which they are connected. In general, a satisfactory value for the resistance is 0.25 megohm, and the condenser should be found by trial for the range of control desired. A common value for the condenser is 0.01 μ F with transformer coupling and for resistance coupling also when the coupling resistance has a high value. When a low value of coupling resistance is used, however, the capacity must be larger and 0.02 μ F may be needed. This value is also often suitable when the tone-control is connected across the output transformer primary, but the resistance can then be reduced to some 50,000 ohms.

An accentuation of the treble can be obtained if an inductance is inserted in series with the condenser, and the resistance has a fairly low value. The discrimination in favour of the higher frequencies is only obtained at the expense of amplification, however, so that varying the control resistance has a large effect on the volume. In general, the inductance should be about 0.1-0.2 H. and the resistance 1,000-5,000 ohms with $C = 4\mu$ F.

The tone control circuit of Fig. 40 may be used to accentuate the bass response with no alteration except to the values of components. The condenser C must then be large, 0.1 μ F or so, and the resistance low, 1,000-5,000 ohms. Here again, a variation in the value of the resistance has a large effect on the amplification.

It should be understood that both these accentuation circuits must only be employed in the early stages of an amplifier where the amplitudes are low, otherwise serious amplitude distortion may occur. They both reduce the amplification by at least the amount of compensation required, so that their use will often necessitate the addition of an extra stage. Further details of such circuits are given in Chapter 24.

Amplitude Distortion

The second type of distortion is also quite common and far less tolerable. Amplitude distortion occurs through non-linearity in some part of the receiver, usually a valve, but iron-cored chokes and transformers can cause such distortion, and it makes the reproduction of a harsh rasping character, particularly at large volume. When valves are correctly operated, the degree of distortion which they introduce is quite small provided that the input signal voltage does not exceed a certain figure.

WIRELESS SERVICING MANUAL

The amount of distortion is measured by the amplitudes of the harmonics relative to the fundamental frequency and is expressed as a percentage. It is usual to take the overload point of a triode as the one at which the second harmonic is 5 per cent. of the fundamental, and of a pentode when the square root of the sum of the squares of the second and third harmonics is 10 per cent. of the fundamental.

This degree of distortion is usually considered tolerable, but for the finest results the distortion in each stage should be kept much lower, otherwise the total will be excessive. When comparing figures for the power output of valves, however, care should always be taken to see that the figures are all for the same degree of distortion, for the above definitions are not always adhered to.

Check Voltages and Currents

Such points are of minor importance in service work, however, for the distortion which has to be remedied is usually a defect which has occurred in previously good apparatus. Where distortion is encountered, the first step should always be to check over the voltages and currents of all valves, not forgetting the filaments or heaters, for the commonest cause of distortion is a defective valve, or a defect in the circuits supplying a valve, which has resulted in incorrect voltages being applied to it. Most distortion, therefore, will be automatically located during the initial routine tests, and once the cause has been found a remedy is usually easy.

It is useful to remember that with Class "A" amplifiers, distortion caused by a valve is nearly always accompanied by a change in the anode current. Much information can be gained, therefore, by connecting a milliammeter in the anode circuit of the suspected valve and watching it when a signal is applied. For complete freedom from distortion the meter needle should remain perfectly steady, but in practice when the volume is at a normal level the needle will kick slightly on loud passages of music. Slight kicks are thus unimportant, but even on loud passages, the change of anode current should not be allowed to exceed about 5 per cent. of the standing current.

With triode valves, when dealing with resistance-coupled amplifiers or with transformer-coupled stages having grid-circuit decoupling, it is often possible to determine the cause of the distortion from the direction in which the meter needle kicks. With a valve having a high resistance in its grid circuit,

FREQUENCY AND AMPLITUDE DISTORTION

an upwards kick of the meter needle indicates that the distortion is occurring through anode bend rectification, that is, the valve concerned has too low an anode voltage, too high a grid bias, or too small an anode circuit load impedance.

On the other hand, if the meter needle kicks downwards, the valve is passing grid current on the positive peaks of the signal, and this is a sign that the grid bias is insufficient. When dealing with pentodes, however, a decrease in the anode current does not necessarily mean grid current, for it can also occur through incorrect anode circuit conditions.

Resistance-coupled pentode intermediate stages are much more likely to cause distortion than triode stages because their operating conditions are more critical. The anode coupling resistance, the screen-feed resistance and the cathode-bias resistance are all closely inter-related, and it is usually very important that the screen voltage should be lower than the anode voltage. An anode coupling resistance of 0.1–0.5 megohm is often adopted and the anode is only about 60 volts positive. The screen must then be at about 20–30 volts only and accordingly the screen-feed resistance is about 0.3–2 megohms. With such low voltages the currents are low, and a high value cathode-bias resistance is needed to give the necessary bias—it is often 2,000–5,000 ohms.

Any large increase or decrease of the resistance values, especially the ones in the screen and cathode circuits, can result in appalling distortion, for the working point is easily shifted on to the bends in the characteristic. On account of the high values of resistance voltage checks are not always of much help, for the voltmeter itself draws too much current. The best way is to check the resistance values with the ohmmeter, and then to measure the currents with the milliammeter. The actual voltages are then easily calculated.

Class "AB" and Class "B" Stages

As already stated most types of amplitude distortion occurring in A.F. circuits are readily detected by the usual meter tests. An exception occurs when dealing with Class "AB" and Class "B" output stages, for with these it is normal for the anode current to rise with a signal. The definitions of these types of amplifier are given in Appendix I, and it will be seen that each type can be sub-divided into two according to whether or not it is driven into grid current. The subscript "2" indicates that grid current is permitted.

These systems are not often found in A.C. broadcast receivers.

WIRELESS SERVICING MANUAL

They occur chiefly in P.A. amplifiers, but they are likely to be found in any equipment with an output exceeding about 15 watts. For broadcast use they are commonest in battery sets.

It should be understood that these systems are really something of a compromise between quality and economy of power supply. They can only give perfect results when valves and components are also perfect. This applies, of course, to any arrangement, but the effects of small departures from perfection are much more serious than is the case with Class "A" amplifiers.

The usual cause of distortion developing in battery-operated Class "AB" and Class "B" amplifiers is nothing more serious than an ageing H.T. battery. As a battery grows old, not only does its voltage fall but its internal resistance rises, and it is this increase of internal resistance which has such a serious effect upon the quality of reproduction. With Class "A" amplifiers it has little effect, for the average current is constant, but with quiescent output stages resistance in the H.T. supply causes the H.T. voltage to fluctuate in sympathy with the anode current variations, whereas it should remain constant. An H.T. battery which may still be good enough for a satisfactory performance with a Class "A" amplifier may thus have to be discarded when a quiescent type of output stage is employed.

Parasitic Oscillation

Apart from the H.T. supply, the only defect which is likely to develop in such amplifiers is greater deterioration in one valve than the other or in one-half of the output valve than the other where a double valve is used. When distortion is very severe, one should always check the anode currents of the two sides of the output stage. Class "B" valves are often two triodes, and Q.P.P. (or Class "AB") valves two pentodes, built into a single bulb, and the filaments of the two valves are connected in parallel. It is, therefore, quite possible for one filament to break without the other, and the receiver will continue to function in spite of this, but there will be severe distortion.

A check of the anode currents is the easiest method of testing for this, and if it be found that one side passes no current it is certain that one filament is broken, provided that everything else is in order.

Excessive grid bias is another cause of distortion with such valves, and in the interests of quality it is inadvisable to make

FREQUENCY AND AMPLITUDE DISTORTION

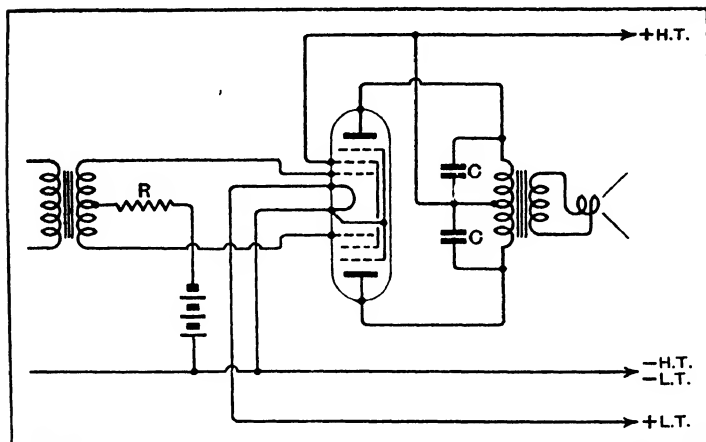

Fig. 41 : When the stage is not driven to grid current a resistance R is advisable to prevent parasitic oscillation

the initial anode current very small. It is often thought that this quiescent current can be as low as 1-2 mA, but in general a considerable improvement in quality is evident when the grid bias is reduced slightly so that it is some 3-5 mA. The improvement is particularly noticeable at low volume.

One of the greatest bugbears of quiescent output stages is parasitic oscillation. It is difficult to trace because it may not be present in the quiescent condition but only on the peaks of the signal, and it is difficult to cure because many of the usual remedies are inapplicable. Anode circuit stopping resistances cannot be used because of the fluctuating anode current, but with a Class "AB₁" or Class "B₁" stage it is permissible to employ stopping resistances in the grid circuit. It has been found, however, that resistances in each grid lead are not always as effective as a single resistance in the lead to the centre-tap on the input transformer as shown at R in Fig. 41.

The value of this resistance is not critical and satisfactory results are usually secured when it is about 150,000 ohms; it should not, in general, be lower than this figure. The by-pass condensers C in the anode circuit are also advisable in most cases, partly to prevent the load on the valve from rising to an excessive degree at high frequencies, but chiefly because they also tend to prevent parasitic oscillation. They are usually

WIRELESS SERVICING MANUAL

given a value of $0.005 \mu\text{F}$ each, and if these condensers be employed in conjunction with the grid circuit resistance R little trouble from parasitic oscillation will usually be experienced.

The difficulties with a Class "AB₂" or Class "B₂" output stage are considerably greater, however, for since grid current flows it is not permissible to connect resistances in series with the grid circuit. It is customary to connect condensers of about $0.005 \mu\text{F}$ across each half of the output transformer primary for the same reasons as in the case of a Class "AB₁" or Class "B₁" stage; these are indicated as C_2 in Fig. 42, which shows the driver and output stages. The centre-tap of

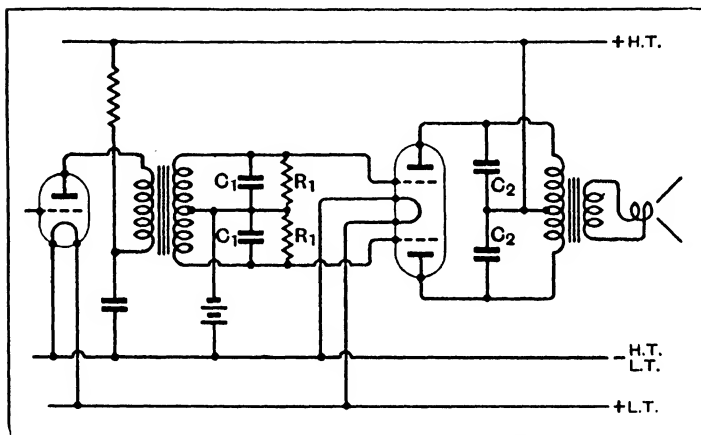

Fig. 42 : The connection of resistances and condensers across the driver transformer of a Class "AB₂" or Class "B₂" stage is sometimes necessary

the driver transformer secondary must be joined directly to the bias battery, if the valve is of the type requiring a negative grid bias, or to $-L.T.$ if it is not.

The resistances R_1 and condensers C_1 are usually omitted, but if parasitic oscillation be present, their addition may effect a cure. The condensers should be tried first and the optimum value is usually about $0.01 \mu\text{F}$, but really depends on the input impedance of the output valve. Larger capacities are permissible with valves operating with zero grid bias than with types requiring a negative bias.

FREQUENCY AND AMPLITUDE DISTORTION

Damping the Driver Transformer

If the addition of the condensers proves ineffective, the resistances R_1 should be tried also. Here, again, the value depends upon the input impedance of the valve and a lower value can be used with the zero bias type of valve than with the negative bias kind. The resistances, moreover, absorb power which must be supplied by the driver so that when they are used, and particularly when they are of low value, a larger driver valve or an increase in its anode voltage, or both, may be necessary to prevent overloading in the driver stage. In general, the resistances R_1 should be about 5,000–10,000 ohms.

One factor which greatly tends towards the production of parasitic oscillation is leakage inductance in the driver and output transformers. Some leakage is always present, but care should always be taken to select good quality components in which the leakage inductance has been reduced to a minimum by the proper sectionalization of the windings.

The Detector

Distortion is by no means confined to the A.F. stages, however, and the detector is a prolific source. Grid detectors have a bad name for quality, but this is only justified when the operating conditions are incorrect. Properly used, the grid detector is very nearly free from distortion ; it is certainly

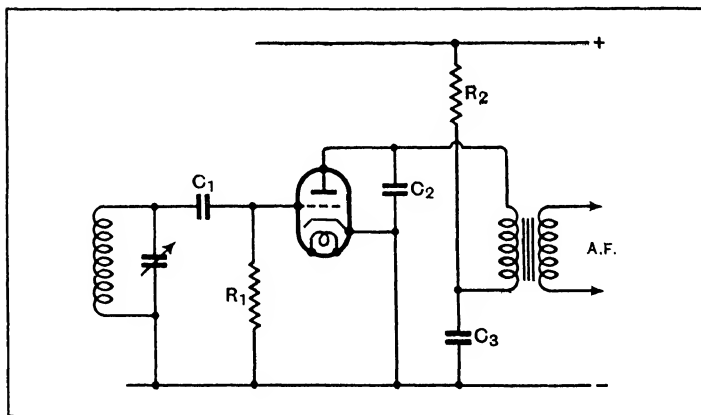

Fig. 43 : The circuit of a typical grid detector

WIRELESS SERVICING MANUAL

much better than the anode bend detector and introduces no more distortion than a good diode detector. The grid detector, in fact, is nothing more than a diode detector and a triode A.F. amplifier in which a single electrode—the grid—serves as a diode anode and as the control electrode of the amplifier.

For correct operation, therefore, the grid circuit must be designed for detection and the anode circuit for amplification. In order to obtain distortionless reproduction the signal input should be large, the grid condenser C_1 (Fig. 43) should not exceed $0.0001 \mu\text{F}$ and the grid leak R_1 should not be greater than 0.25 megohm. In a mains set, the grid leak must be returned to cathode, but in a battery set it should normally be taken to positive L.T. To obtain distortionless amplification in the triode action of the valve, the signal input should be small, the anode circuit load impedance high and the anode voltage high.

It will be seen that one of the requirements for distortionless detection in the grid circuit is just the opposite of one of those for distortionless amplification, and this is the weak point of the grid detector. If the input required for distortionless detection is greater than the maximum for distortionless amplification, distortion is inevitable, but if the converse is true, then there need be very little, if any, distortion.

The minimum input for distortionless detection varies very little from valve to valve and there is little which can be done to alter it. The maximum input which the valve can accept as an amplifier, however, is easily controlled and increases with the anode voltage. A valve with a low amplification factor is also advisable.

In general, practically perfect detection will be secured if the anode voltage be adjusted so that, with no signal, the valve passes an anode current of 6 – 10 mA, the higher the better, and the signal input is of such a value that the current falls by about 20 per cent. on the application of a signal. Both post- and pre-detector volume controls are thus really necessary for the highest quality together with a milliammeter permanently wired in the detector anode circuit. The pre-detector control should be used to adjust the detector input to the optimum value for any station, as indicated by the meter, and the post-detector control should be employed to adjust the volume to the required level.

When used with a small signal input, the grid detector, in common with both anode bend and diode detectors, will introduce considerable distortion which may be as high as

FREQUENCY AND AMPLITUDE DISTORTION

25 per cent. A large input is always needed for distortionless rectification, and the great advantage of the diode detector is that there is no factor in the detector which limits the input permissible.

Anode Bend Rectification

With anode bend rectification it is necessary to avoid any flow of grid current if distortion is to be avoided, and the best results are usually secured by employing a valve of moderate internal resistance with a high anode voltage and a value of grid bias sufficient to reduce the anode current to about 0.1 mA with no signal. The anode current rises with a signal and, just as in the case of the grid detector, there is an optimum change of anode current for quality. It is hardly possible to give even an indication of this optimum figure, however, for it is dependent on so many factors which vary from set to set; it will, however, rarely exceed 1 mA.

The diode detector performs only one action, that of detecting, and gives no amplification at all. In the ideal case it has no overload point, but in practice an upper limit is sometimes set to the input by the risk of a breakdown in the diode if this voltage be exceeded. Most diodes, however, even the small ones fitted to multiple valves, will withstand an input of 50 volts or so safely, and some of the duo-diodes as much as 200 volts. In the ordinary receiver, therefore, the diode detector input is not critical, and the detector will not introduce appreciable distortion as long as the input exceeds a certain minimum figure. This lower limit varies with different diodes and their operating conditions and may be as small as 1 volt or as high as 10 volts.

A typical diode detector is shown in Fig. 44. Although practical circuits may differ somewhat in detail, particularly when multiple-valves are used, the connections are always based on this diagram. The requirements for correct operation are that the load impedance to modulation frequencies shall be

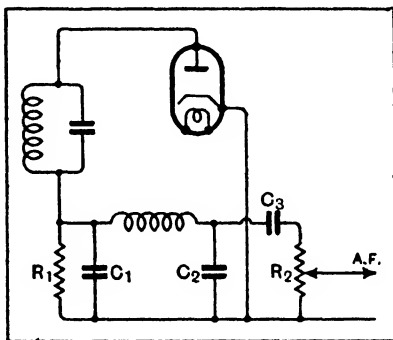

Fig. 44: The diode detector is almost universal in modern receivers

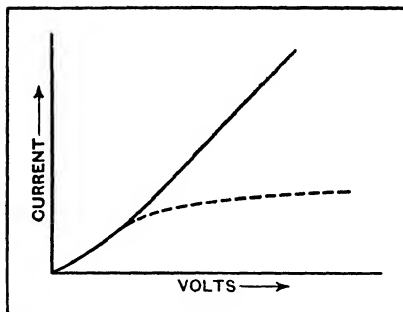

Fig. 45 : The solid line curve represents the normal characteristic of a diode, but if the emission fails the curve assumes the form of the dotted line

high compared with the diode impedance, and roughly constant over the whole range of modulation frequencies, while it shall not be greatly less than the D.C. resistance. The load impedance at the carrier frequency, however, should be small.

The load at very low frequencies is provided by the resistance R_1 which is also the D.C. resistance of the load.

Maximum linearity is obtained when it has a high value, but at high modulation frequencies it is shunted by C_1 and C_2 . The reactance of the former represents the load at the carrier frequency and must be as small as possible. The reactance of C_2 must also be kept small, otherwise the filter circuit is of little benefit. There is consequently a maximum value for R_1 when the highest quality is required. Normal values for C_1 and C_2 are $0.0001 \mu\text{F}$ with R_1 about 0.25 megohm ; sometimes, however, the values are four or five times as large, but there is then likely to be some loss of quality.

Even ignoring the shunting effect of the capacities, however, the resistance R_2 , which is normally the volume control, can cause distortion, for it is effectively in parallel with R_1 as far as modulation frequencies are concerned and the A.C. impedance of the load circuit is less than its D.C. resistance. It can be shown that when R_2 is four times the value of R_1 , distortionless rectification can be secured for modulation depths up to about 80 per cent. and this is quite good enough even for high quality apparatus. Thus, when R_1 is made 0.25 megohm, R_2 should not be less than 1 megohm. The coupling condenser C_3 is, of course, chosen in relation to R_2 just as for a resistance-coupled amplifier, and a normal value is $0.01-0.1 \mu\text{F}$.

Few defects are likely to arise in a circuit of this nature, apart from open or short circuits. It should be remembered, however, that if R_2 changes its value so that it is no longer large compared with R_1 , distortion will be evident and will be severe if R_2 is much smaller than R_1 . A short-circuit between

FREQUENCY AND AMPLITUDE DISTORTION

the slider and the upper end of R₂ causes severe distortion at low volume, but has no effect at full volume. One other fault may be found and this lies in the diode itself. The normal characteristic is of the form shown by the solid line of Fig. 45 but, should the emission fail either through age or through an overload, it assumes the form of the dotted curve and distortion is likely to be severe with large detector inputs, while the efficiency falls off.

Pre-Detector Stages

Turning now to the R.F. or I.F. side, serious distortion may easily occur in these stages. This is not as well known as it should be, for although the frequency distortion caused by excessive selectivity is usually recognised, few realise that amplitude distortion may be quite as great in these circuits as in the A.F. stages.

Trouble rarely occurs when receiving weak signals, and it is normally at its worst in local-station reception, and particularly when the aerial system is good. If the set is not fitted with A.V.C., the first valve is more likely to be responsible than the last R.F. or I.F. amplifier, but it is not necessarily at fault, since the trouble can arise in any stage. If the set has A.V.C., however, the last stage is usually responsible.

Variable-mu valves are, of course, practically essential when volume is controlled, as it always is nowadays, by varying the grid bias, and valves with long grid bases are often better than those requiring only a small bias for anode current cut-off. Whatever arrangement is used, however, it should be understood that an overload point always exists; there is a certain signal strength which must be considered a maximum for that set, and distortion, and often reduced volume, will be found if a stronger station be tuned in.

Controlling the Input

With a good set containing no defect, such trouble is not likely to be found at more than 10 miles or so from a local station and then only when a particularly good aerial is used. Two remedies of a simple nature are available. The first is to fit a local-distance switch to reduce the input to the set for local reception. There are many ways of doing this, but one of the best is to fit a make-and-break switch to connect a resistance between the aerial and earth terminals. The value of the resistance should be found by trial, since the optimum value depends on local conditions. It will, however, normally be of the order of 100 ohms.

WIRELESS SERVICING MANUAL

The second remedy is better in that it involves no additional control and it reduces any interference caused by the local stations ; it is particularly valuable with superheterodynes, for it greatly reduces any tendency to whistle production. It consists of connecting a wavetraps in the aerial circuit and tuning it precisely to the local station. If there are two local stations, two wavetraps should be used.

There are, however, faults in the receiver which can cause distortion in the reception of local stations. Defects of this type which cannot be located by the usual voltage and current tests are most likely to reside in the A.V.C. system. Open-circuited resistances, short-circuited or leaky by-pass condensers, or an open-circuited condenser feeding the A.V.C. diode may be responsible. A defective A.V.C. diode itself, however, may be the cause, and this is particularly likely to be the case if the receiver functions normally on all but the local stations.

It is easy to see that if the diode loses its emission, the set will function normally provided that the signal voltages are not so great as to cause the A.V.C. diode input to pass beyond the straight part of the dotted curve of Fig. 45. On strong signals, however, a limit is soon reached to the possible A.V.C. bias, and overloading occurs in an early stage, whereas the bias would continue to rise with a good diode having a characteristic like that shown by the solid line.

Some A.V.C. systems inherently introduce amplitude distortion. They are usually particular varieties of delayed diode systems, and although they were considered satisfactory some years ago they are not now to be recommended. The circuits in question are dealt with in Chapter 16, and where one is found to be causing distortion one of the more modern alternatives is recommended.

CHAPTER 9

BACKGROUND NOISE AND LOCAL INTERFERENCE

THE average listener finds noisy reception far more irritating than many other faults, but there are so many possible causes of noise, that the mere statement that a receiver is noisy is of no help in diagnosis. It can be one of the easiest of all defects to trace, but it can also be the most difficult ; a cure, in fact, is not always possible.

The commonest cause of noise is a loose connection and it is the easiest to trace, for in nearly every case it can be located by tapping every part of the set in turn. The noise takes the form of a characteristic crackle which is readily recognisable. It should not be forgotten, however, that trouble of this nature may not always lie in the receiver itself.

In a battery set, the H.T. and L.T. leads should be suspect, and in a mains set the mains flex should not be overlooked. The aerial and earth must always be remembered, particularly when the noise is intermittent. The author has come across many cases of noisy reception and intermittent changes of volume being due to nothing more than a down-lead wire rubbing against a gutter, or a bad connection at the lead-in tube.

Never forget to examine the earth lead. This is just as important if the earth connection has been recently installed as it is when it has been there for years. Gardeners seem to consider an earth as a new variety of weed and treat it accordingly ; if they do not uproot it entirely, they try the effect of their pruning shears on the earth lead.

The difficult types of noise may be divided into two classes, those which occur in the receiver and those which are external in origin. The internal noise is usually in the form of a hiss which appears whenever a signal is tuned in and may be of great intensity. It is commonly known as superheterodyne hiss, but it is by no means a monopoly of the superheterodyne, and this name for it is really an undeserved libel on this excellent receiver.

The limit is reached when the noise voltage on the grid of the first valve, due to thermal agitation of the electrons in the conductors forming its grid circuit, is of the same order as the signal voltage. Actually, the signal must be rather stronger than this, for the first valve also introduces some noise. At the present time, the limit for a well-designed set is reached with a sensitivity of about $1 \mu\text{V}$. That is to say, if a set has this

WIRELESS SERVICING MANUAL

degree of sensitivity it will give standard output for a signal producing $1 \mu\text{V}$ between the aerial and earth terminals, but the internal noise will, in practice, be inevitably of the same order. It is, therefore, useless to attempt to receive weaker signals, for they will be swamped by the set noise.

It should not be thought, however, that a set of high sensitivity will give more noise on strong signals than one of low sensitivity. It will not, for the two sets will have the same sensitivity on that particular signal, since the amplification will be reduced either by the A.V.C. system or by the manual volume control. Actually, the highly sensitive receiver may be slightly the quieter since it is not so likely to be operating near a point of instability.

In any case, however, with a given set the background hiss increases as the signal input to the set is reduced. It is, therefore, important to use as good an aerial as possible and to couple it to the set efficiently.

These remarks apply to all sets, straight and superheterodyne, and if both sets be properly designed there is nothing to choose between them on the score of background hiss. In practice, however, the superheterodyne is more liable to develop excessive hiss than the straight set, and it is this excessive hiss which is important, for it is as much a fault as a loose connection.

There is no doubt whatever that the commonest cause is a defective valve, usually the frequency-changer, but it may be caused in some degree by any defect in the pre-frequency-changer circuits which has the effect of reducing the efficiency. Next in order comes parasitic oscillation. This is usually unsuspected and is unfortunately rather difficult to trace, but the author believes it to be responsible for much background noise. It can occur in R.F. or I.F. stages, but is more likely to be found in the oscillator.

Parasitic R.F. Oscillation

When parasitic oscillation occurs in an R.F. or I.F. stage it may usually be stopped by inserting suitable resistances in the grid and anode circuits just as in the case of an output valve. The resistances should be non-inductive and of low capacity—the ordinary metallised or compound resistances are suitable—and mounted as closely as possible to the grid and anode. With care the leads to the resistances need not exceed a quarter of an inch. The grid resistance can usually have a value of 100–500 ohms, and the anode resistance can be about 100–1,000

BACKGROUND NOISE AND LOCAL INTERFERENCE

ohms. If there are several stages of amplification it is sometimes helpful to use different values for the different stages.

Parasitic oscillation is much more likely in the oscillator, for the operating conditions are already suitable for oscillation. Parasitic oscillation really means oscillation at any undesired frequency, but the term is usually employed to denote unwanted oscillation at a frequency much higher than that of any circuit *apparently* connected to the valve. Every wire in a set has some inductance and has some capacity to other leads. All sorts of unsuspected tuned circuits may be present, therefore, and if they are suitably coupled oscillation may occur at very high frequencies—60 Mc/s and even higher. Such oscillation is difficult to detect except by its adverse effect upon the performance of the receiver.

The best method of detecting parasitic oscillation in the oscillator of a superheterodyne is by checking the grid current. Most modern frequency-changers use a grid leak type oscillator with a grid leak of about 50,000 ohms, and the grid current is about 0.1–0.5 mA. If a meter having a maximum scale reading of about 1 mA is available, it should be connected between the grid leak and cathode, the positive terminal being joined to cathode. The reading of the meter will depend upon the amplitude of oscillation, the peak oscillator grid voltage being nearly equal to 1.2 times the product of the grid current (in amperes) and the grid leak (in ohms).

As the tuning control is rotated it will be found that the current varies somewhat, usually falling at the lower frequencies, for it is impracticable to maintain the amplitude of oscillation quite constant over the waveband. The change in current, however, should be quite smooth, and if it be found at any point that there is a sudden jump either up or down in the current, parasitic oscillation is almost a certainty.

If a suitable meter is not available for this

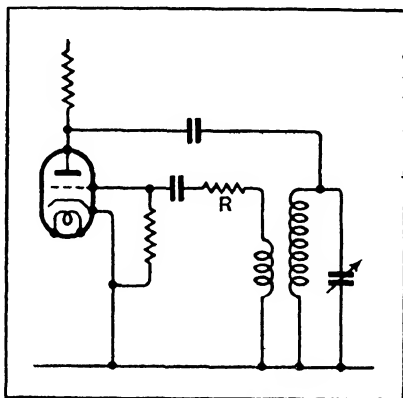

Fig. 46 : The connection of a resistance R in series with the reaction coil of an oscillator will often cure parasitic oscillation

WIRELESS SERVICING MANUAL

test, it may be carried out with a milliammeter connected in the oscillator anode circuit. With a grid leak oscillator the anode current falls when the valve commences to oscillate, but the magnitude of the change of current is not a reliable guide to the amplitude of oscillation. A sudden kick of the meter needle when the oscillator is tuned over its band, however, can be taken as an indication of parasitic oscillation.

The remedies must usually be found by trial and error ; it is often advantageous to rewind the reaction coil with resistance wire, but as this may be inconvenient it is usually as satisfactory to wire a resistance in series with it as shown in Fig. 46. Such a resistance R should have a value of 100-5,000 ohms. It will, of course, reduce the amplitude of oscillation at the correct frequency, but this is not usually very important : certainly not if it prevents parasitic oscillation. It may be remarked that the choice of a suitable value will enable nearly constant amplitude to be obtained throughout the waveband.

Local Interference

Perhaps the most commonly encountered noises, however, are due to no defect in the receiver, but are of external origin and are usually known as man-made static. It is usually easy to distinguish the types, because set noises are normally in the form of a hiss whereas external noise is generally less continuous and sharper in character, resembling a more or less continuous barrage of atmospherics.

Such interference can be generated by any electric motor, other than the synchronous and squirrel cage types, by thermostats, generators, flashing signs, automatic telephones, and internal combustion engines, to mention only the chief sources. Whatever its source, the interference reaches the receiver in one or more of three different ways—by direct radiation from the source picked up by receiver or aerial, by conduction along the supply mains, or by radiation from the supply mains.

The best method of avoiding such interference is nearly always to suppress it at the source by connecting suitable suppressors to the apparatus causing the interference. This is, unfortunately, not always possible, for the sufferer is not always the owner of the apparatus responsible for the trouble. If tactfully approached, however, most owners will be willing to discuss the matter and few will object to the necessary suppressors being installed.

In cases where nothing can be done to eliminate the interference at its source, however, it is necessary to consider

BACKGROUND NOISE AND LOCAL INTERFERENCE

alternative methods. When the interference is outside the premises on which the receiver is operated the connection of a filter to the supply mains at the point where they enter the house is usually effective in reducing the interference, for it greatly reduces both that portion which is conducted by the house wiring and that portion which is radiated from it.

With D.C. mains, condensers connected to the mains as in Fig. 47 (a) are usually satisfactory, but for A.C. supplies the arrangement of (b) is to be advised. The condensers should have capacities of about $1 \mu\text{F}$ and the fuses protecting them should be rated at 2 amperes. The condensers themselves must be of good quality and high voltage rating.

When fitting suppressors it is essential that the connecting leads be very short, for even the small inductance of a few inches of wire may seriously reduce the efficiency of the device. In no case should the leads to the condensers exceed 6 or 8 in. and the earth should be good.

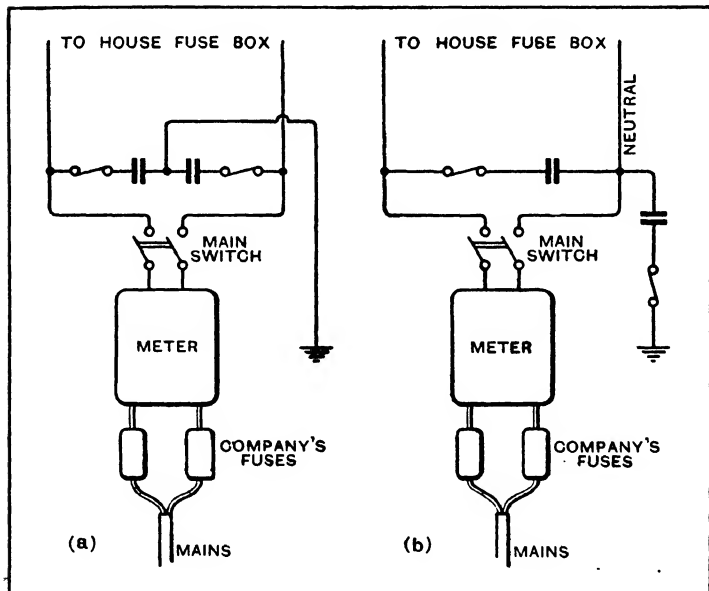
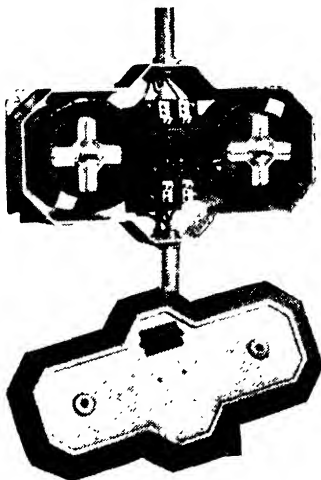

Fig. 47 : The method of connecting filters to the mains is shown at (a) for D.C. supplies and at (b) for A.C. mains

WIRELESS SERVICING MANUAL

In extremely bad cases of interference it may prove necessary to supplement such a suppressor with choke coils. One coil should be connected in series with each mains lead, usually between the point at which the suppressor is joined and the house wiring. Sometimes, however, the coils are better placed between the suppressor and the main switch.

When the house wiring has thus been isolated from interference, any which remains is likely to be due to external radiation. If the interference persists when the aerial is disconnected from the receiver, a simple filter should be tried across the mains feed to the receiver itself. Such a filter can consist of two $0.01 \mu\text{F}$ condensers, one being connected from each side of the mains to earth. If the interference still persists, the screening of the receiver is probably defective.



Belling-Lee
Interference
Suppressor

When silent operation has been secured with the aerial disconnected, any interference which occurs when it is in use is obviously due to pick-up by the aerial and its lead-in themselves; the ideal remedy is to employ an aerial which will not pick up interference but which will still pick up signals. There is, however, no such aerial, for the signal and interference are both waves in space and the property of the aerial which enables it to respond to the one must also let it respond to the other.

The only course, therefore, is to erect the aerial at a point

BACKGROUND NOISE AND LOCAL INTERFERENCE

where it is outside the field of the interference. Little or nothing can be done with an indoor aerial, but an outdoor aerial which is at a greater distance than 10 ft. or so from any part of the house is likely to pick up little interference except from such serious sources as tramways or electric railways.

Although such an aerial may itself pick up little interference, the lead-in, if of ordinary type, will certainly do so, for it will pass through the field of interference. It is necessary, therefore, to use a special form of lead-in to prevent such pick-up. The simplest course is to use a screened lead-in with low-capacity screened cable, the lead-in being screened the whole way from the junction with the horizontal span of the aerial to the receiver itself. This is not always convenient, however, for the overall diameter of such cable is about $\frac{1}{2}$ in. to 1 in., and in addition to mechanical difficulties in its disposition, it may, in some cases, be considered unsightly.

As an alternative, ordinary screened cable with an overall diameter of less than $\frac{1}{4}$ in. can be used with impedance matching transformers at each end. Suitable transformers are obtainable commercially, and one is mounted at the junction of the lead-in with the aerial while the other is fitted at the receiver itself. Some loss of efficiency is inevitable with all screened down-lead systems, but this is not usually serious over the greater portion of the waveband. In any case, it is a small price to pay for the reduction of interference.

A screened lead-in introduces far too great a loss to be satisfactory for short-wave reception unless proper R.F. cable can be obtained. The alternative is to use a transposed feeder as a lead-in. This may also be used on the medium and long wavebands. As shown in Fig. 48, two separate lead-in wires are used and are run about 2 in. apart, being transposed every 1 to 2 ft. by using transposition blocks. Only one of the wires is connected to the aerial, the other being left free at its upper end.

With this system, the aerial winding on the first tuned circuit in the receiver requires modification, for it must be earthed at its centre-point and the two lead-in wires joined to the ends of the winding. Ideally, the winding should be electrostatically screened from the secondary, but this is not always necessary. The operation of this system depends upon the fact that each lead-in picks up the interference equally, but as they are coupled to the tuned circuit equally and in opposite phase the interference balances out, leaving only the signal picked up by the aerial proper.

WIRELESS SERVICING MANUAL

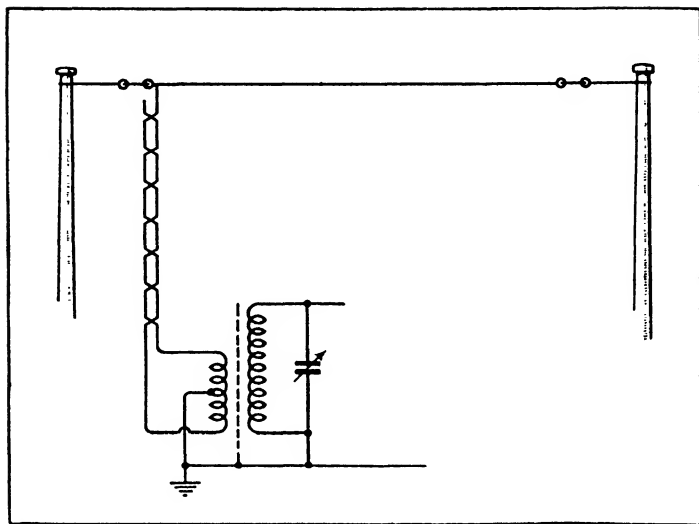

Fig. 48 : An anti-interference system employing a transposed feeder for the lead-in

The use of a screened lead-in or transposed feeder is also the only practical method of countering the interference caused by tramways and railways, but it is not usually as effective as it is in the elimination of other types of interference. It must be remembered that these methods are only useful when it is possible to erect the aerial itself at a point which is free from interference, and this is not always possible when the trouble is due to trams.

It is very often found that interference is caused by apparatus on the same premises as the receiver, and although the screened lead-in may be one remedy, it is usually better to silence the gear responsible; this is not only likely to be more effective, but will also prevent interference in neighbouring sets. Incidentally, the mains filter already described is of no use in this case, and is unlikely to cause any reduction of interference in the same house, although it may do so in neighbouring premises.

The usual offenders are fans, hair dryers, vibrators, vacuum cleaners, floor polishers, sewing machines, refrigerators, and the like. Vacuum cleaners and floor polishers are not usually

BACKGROUND NOISE AND LOCAL INTERFERENCE

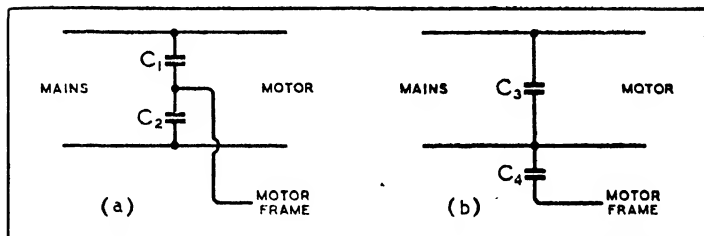

Fig. 49 : For suppressing the interference caused by small motors the arrangement of (a) is often used with D.C. supplies, and that of (b) with A.C.

important, for they are generally used only for short periods and in the morning. Fans and refrigerators are the most important, for in hot weather they are likely to be in more or less continuous operation. In general, the simple filters shown in Fig. 49 will prove satisfactory; the arrangement at (a) is for D.C. mains and that at (b) for A.C. When the frame of the motor is not earthed, C_1 and C_2 can be $0.1 \mu\text{F}$, while for A.C., C_3 should be $0.1 \mu\text{F}$, with C_4 only $0.01 \mu\text{F}$. If C_4 be made larger, there is a risk of shock on touching the metal casing of the motor.

Silencing Thermostats

Better suppression is likely to be obtained when the frame is earthed, and this should always be done when possible even if it means the use of 3-pin plugs and a 3-way cable in the case of portable apparatus. When the frame is earthed, all the condensers of Fig. 49 can have the same capacity of $0.1 \mu\text{F}$ to $1 \mu\text{F}$.

In all cases, the suppressor unit should be mounted actually on the apparatus itself so that the leads from the condensers to the motor can be very short. In this connection, it may be remarked that especially convenient suppressor units which are designed for insertion in the flexible leads are commercially obtainable.

Such simple filters often fail in the case of refrigerators, for

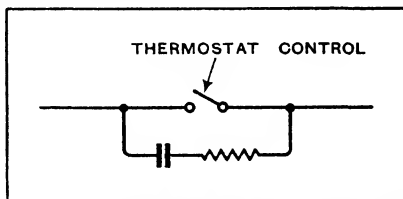

Fig. 50 : A resistance-capacity circuit forms an effective suppressor for a thermostat

WIRELESS SERVICING MANUAL

although they may silence the motor, they do not always reduce the interference caused by the thermostat. The remedy is to connect the series combination of a resistance and condenser across the contacts of the thermostat as shown in Fig. 50. The condenser should have a capacity of $0.1 \mu F$, while the resistance should be 50–200 ohms ; it is often necessary to find the best value of resistance experimentally, for it may be fairly critical.

In a book of this nature no attempt can be made to deal in any detail with the many different cases which can arise in practice. The commonest causes of interference and the remedies have been indicated and to those wishing for fuller information regarding the suppression of man-made static three publications can confidently be recommended : “ British Standards Specification for Components for Radio-Interference Suppression Devices,”¹ “ Interference Suppression,”² and “ Radio Interference Suppression ”³ by Gordon W. Ingram, B.Sc.

¹ The British Standards Institution, Publications Department, 28 Victoria Street, London, S.W.1. Specification No. 613. 1940.

² Belling & Lee, Ltd., Cambridge Arterial Road, Enfield, Middlesex.

³ Electrical Review, Ltd., Dorset House, Stamford Street, London, S.E.1.

CHAPTER 10

THE ADJUSTMENT OF GANGING—STRAIGHT SETS

THE performance of a receiver depends very greatly upon the accuracy of the ganging. Each tuned circuit must be resonant to the incoming signal if the correct results are to be secured, and if one or more is mistuned both sensitivity and selectivity are bound to suffer. The design of circuits which are capable of being accurately ganged offers many problems which concern few but the set designer. The adjustment of the ganging, however, is a relatively simple matter and, if the receiver is in good condition and the proper apparatus available, it need only occupy a few minutes.

The number of tuned circuits commonly employed in a straight set varies from three to six and, whatever signal frequency the set may be tuned to, all circuits should be resonant at the same frequency. In practice, this is attempted by using tuning coils of nominally the same inductance and a ganged condenser in which the sections are matched so that they are all exactly alike. Trimmers are fitted primarily to permit the equalisation of the stray circuit capacities.

Even when the ganged condenser is at minimum its capacity is not zero, but some $15\text{--}30\ \mu\mu\text{F}$; coils have a self-capacity of $7\text{--}12\ \mu\mu\text{F}$, the valves themselves load the circuit with capacity which may reach $15\ \mu\mu\text{F}$, and the wiring may easily add $5\ \mu\mu\text{F}$. The total effective capacity with the variable condenser at minimum may thus total $50\text{--}70\ \mu\mu\text{F}$, and may exceed this unless care be taken in design.

These capacities restrict the tuning range of a receiver, for with coils of a given inductance the highest frequency (lowest wavelength) to which a receiver will tune is governed entirely by the value of the stray capacities. The stray capacities also govern the lowest frequency to which the set will tune, of course, but they do not then have so great an effect for they form a smaller proportion of the total capacity in circuit.

Now it is clear that the stray capacities are likely to differ widely in different circuits, for in a given receiver one circuit may have two valves connected to it while another has only one; one circuit may be connected to a valve of different type from another, and so on. Trimming condensers are fitted to the circuits, therefore, in order that the capacity of the low-capacity circuits may be brought up to that of the highest so that the capacity in all circuits will be the same.

WIRELESS SERVICING MANUAL

It is theoretically possible by correct design to secure perfect ganging. In practice, it is not, for neither the coils nor the ganged condenser are perfect. No attempt is usually made to match coils more closely than ± 0.25 per cent., and sometimes the limit is as high as ± 1 per cent. The sections of the ganged condenser are rarely matched more closely than ± 0.5 per cent., and more often ± 1 per cent. Even in the best conditions, therefore, the errors are likely to be as high as ± 0.75 to ± 2 per cent., which represent degrees of mistuning of some ± 0.375 to ± 1 per cent.; at 1,000 kc/s, as much as 3,750 to 10,000 c/s.

The best settings of the trimmers, therefore, are not necessarily the ones which equalise the stray capacities but the ones which lead to the best average results over the waveband. The audible effect of the permissible ganging errors is by no means as great as one might suppose, however, and the chief thing to be guarded against is an excess of error. This occurs chiefly in the ganged condenser.

Although its sections may be accurately matched when it is new, they are unlikely to retain that matching after a long period of use. It is not as fully realised as it should be that a ganged condenser is quite a delicate piece of apparatus and easily damaged. A jar which causes no visible defect may appreciably affect the accuracy of the matching, and changes may occur after a period owing to stresses in the metal of the vanes. After adjusting the trimmers it is consequently necessary to check the ganging to make sure that it holds reasonably well throughout the waveband.

The ganging is also affected by regeneration, whether this be due to deliberate reaction or to stray feed-back effects. Regeneration is usually at its maximum when the set is working at full sensitivity and, since in normal use the full selectivity is then most needed, the ganging should be adjusted with the set in this condition.

The Preliminary Steps

If the set has a manual pre-detector volume control, therefore, it should be kept at maximum while ganging, and if it includes A.V.C., only a weak signal should be used so that the detector input is kept below the A.V.C. delay voltage and A.V.C. does not function to reduce the sensitivity. This, of course, necessitates the use of a proper output meter as a ganging indicator, or else obliges reliance on the ear. If an output meter is not available, however, it is usually better to use a larger input

THE ADJUSTMENT OF GANGING .

and a milliammeter or voltmeter as an indicator than to rely upon the ear.

A test oscillator should be used and the low potential side of its output connected to the earth terminal of the receiver, to which the earth is, of course, left connected. The high potential lead should really be screened, but this is not always very important; it must, however, be taken through either an artificial aerial or a $0.0002 \mu\text{F}$ condenser to a lead terminating in a crocodile clip so that it may readily be connected to any portion of the receiver without risk of short-circuit.

In order to gang a receiver on the medium waveband, set the oscillator to 1,500 kc/s and clip its output lead to the grid of the last R.F. valve. Set the tuning condenser in the receiver at minimum and adjust the trimmer on the last gang condenser section for maximum response, adjusting the output of the oscillator to give a convenient indication on the output meter. Then set the oscillator to 1,400 kc/s and tune the set to it exactly by the main tuning control.

Leaving the tuning control at this setting, transfer the oscillator clip to the grid of the preceding valve and adjust the trimmer on the next section of the gang condenser for maximum response. As the circuit comes into resonance the output of the oscillator must be reduced, otherwise the output will be too great to be read on the output meter. When one circuit has been adjusted, transfer the clip lead to the preceding stage and adjust the extra circuits which become operative.

In most cases, where only three or four tuned circuits are used and particularly when the circuits are already roughly tuned, it is unnecessary to go through the whole procedure. After adjusting the last circuit in the manner described, the output of the oscillator can be transferred directly to the aerial terminal and, leaving the last trimmer alone, each of the others can be adjusted in turn, working backwards towards the aerial, for maximum response. When this has been done, it is usually wise to check over the adjustment of all circuits, again starting at the last circuit and working towards the aerial.

If the set has a calibrated tuning dial, the first step of adjusting at 1,500 kc/s is unnecessary. Set the dial to read 1,400 kc/s and the test oscillator to this same frequency. With its output clipped to the grid of the last R.F. valve, adjust the last trimmer for maximum output. Then transfer the clip to the grid of the preceding stage and proceed as described above.

Ganging with Reaction

If the receiver is fitted with reaction, the trimming will be

WIRELESS SERVICING MANUAL

somewhat more difficult, for it is affected by the setting of the reaction control. In general, reaction is needed only when maximum sensitivity and selectivity are required, and it is obvious that the ganging should be accurate under this condition. After ganging in the manner described, therefore, the setting of the reaction control should be increased while retrimming the circuit to which reaction is applied, usually the last, until the set is nearly but not quite oscillating.

It will be necessary, of course, to reduce the output of the oscillator from time to time as the sensitivity increases to keep the needle of the output meter on its scale. The trimming will also become much more critical. When reaction has been set fairly closely to the oscillation point, the early circuits should be retrimmed and it will often be found that the optimum settings are now more critical.

If too much reaction has been used, the set may break into oscillation as the early trimmers approach their optimum settings and if this occurs reaction must be reduced slightly and the last circuit retrimmed.

This completes the ganging if the coils and condensers are well matched, and there is nothing more to be done on this waveband. The procedure on other bands is exactly the same save for the frequency at which it is done. In the case of the long waveband it is usually best to carry out the ganging with the oscillator set to about 300 kc/s (1,000 metres).

Possible Defects

It may be remarked at this point that the purpose of the initial adjustment of the last tuned circuit at 1,500 kc/s is merely to ensure that the set is trimmed with the right capacity in the trimmers to permit the set to be tuned to this frequency. If this is not done, and all adjustments are made at 1,400 kc/s, too much capacity may be used in the trimmers and the correct waveband coverage will not then be secured. In some cases, particularly when trying out a new set, it may be found that no optimum setting for the last trimmer can be found even with the ganged condenser at minimum. This is usually a sign that the stray capacity on this circuit is excessive and an endeavour should be made to reduce it.

If it occurs in a receiver which has previously been satisfactory and which has a triode anode-bend or grid detector, an open circuit in the anode-to-cathode by-pass condenser is the most probable cause. The valve will then give appreciable

THE ADJUSTMENT OF GANGING

R.F. amplification and have a very high input capacity due to anti-phase feed-back through its grid-anode capacity; the input capacity may be as high as $0.0001 \mu\text{F}$, and it will vary over the waveband and so cause poor ganging.

Even when full equipment is not available, ganging is in no way difficult, but if a milliammeter is used instead of a proper output meter as an indicator of resonance in a set equipped with A.V.C., care must be taken to connect it correctly. It can be connected in the anode circuit of any valve controlled from the A.V.C. system, but it must be connected at a point of low R.F. potential. The correct position for the meter is shown at (a) in Fig. 51 on the H.T. side of the decoupling resistance and the wrong position at (b) where the meter is between the valve anode and the intervalve coupling.

In this position the meter will not only increase the stray circuit capacity and so render correct ganging impossible, but it will probably cause

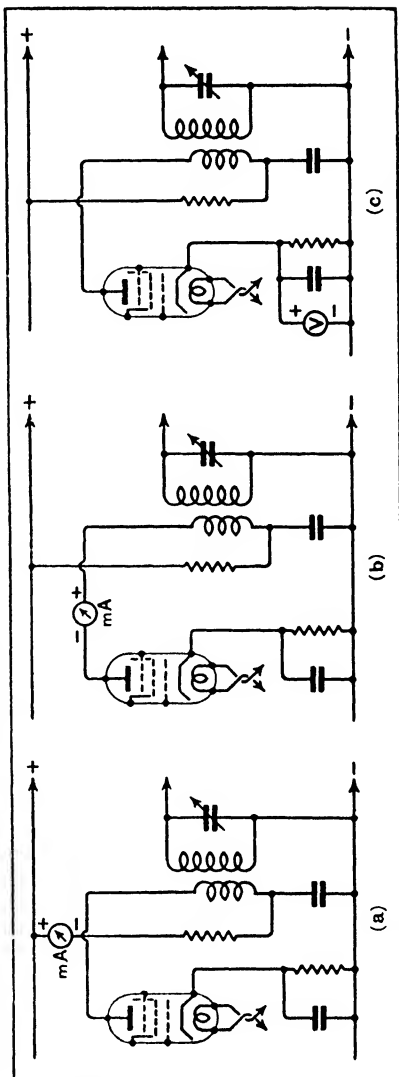

Fig. 51 : The correct position for a milliammeter is shown at (a) and the incorrect position at (b). Alternatively, a voltmeter can be used (c)

WIRELESS SERVICING MANUAL

instability. An alternative indicator which is often more convenient is a voltmeter connected across the bias resistance of one of the controlled valves as shown at (c) in Fig. 51. The indication is not always as good as with a milliammeter, but it is usually sufficient.

Ganging on a Signal

Where a test oscillator is not available ganging must of necessity be carried out on signals and an output meter is then of no value, for the modulation depth of the transmission is constantly varying. A milliammeter or voltmeter as described above can with advantage be used, however. The procedure is practically the same as with an oscillator, but all circuits must of necessity be operative the whole time. The trimmers should first be set at what one would expect to be roughly the correct capacities; that is, the first and last trimmers for the aerial and detector circuits will normally be nearly full unscrewed while other trimmers will usually be set at about one-half of their capacity. No difficulty should then be found in tuning in some signal, and on this each trimmer can be roughly adjusted.

Then tune in a station on as high a frequency (low wavelength) as possible and adjust each trimmer in turn for maximum response, starting with the one nearest the detector and working backwards towards the aerial. Should it be found that for any circuit there is no optimum, but that signal strength increases as the trimmer is unscrewed, it is a sign that ganging is being attempted with too little capacity in the trimmers.

Each trimmer should be screwed up a little, therefore, the station retuned at a lower dial setting, and ganging attempted again. No more capacity than is necessary should be used in the trimmers, of course, otherwise it may not be possible to secure the correct waveband coverage. The treatment of any reaction control is exactly the same as when an oscillator is available.

Although various methods have at times been put forward for checking the accuracy of ganging over the waveband, such as metal spades which reduce the coil inductance when held near them or ebonite plates which increase the condenser capacity when inserted between the vanes, none are of much use in the modern receiver, for coils and condensers are invariably screened. The only satisfactory check is the drastic

THE ADJUSTMENT OF GANGING

one of trying whether a better performance can be obtained at a lower frequency by reganging at that frequency.

It is drastic, because it means that after the check the set must be ganged again at a high frequency. The check, of course, is not to see whether the ganging adjustments have been properly performed, but to see whether the coils and condenser sections are matched. If a check is made at a number of frequencies and it is found that in one circuit the trimmer capacity must be continually increased to maintain resonance as the frequency is lowered, it is highly probable that the inductance of the coil in that circuit is lower than the inductance of the others.

Conversely, if the trimmer capacity needed continually falls with a lowering of the frequency, the inductance is too high. The same effects may be, but are not as likely to be, obtained through mismatching of the ganged condenser sections. If, however, the variations in trimmer capacity are somewhat erratic, it is probably the condenser which is at fault.

If the trimmers be adjusted at 1,400 kc/s, for instance, it may happen that one trimmer needs more capacity at 1,000 kc/s, but that this new value holds for still lower frequencies, while at the lowest frequency possibly less capacity is needed. Such an effect could not possibly be produced by mismatching of the coils, and if the defects mentioned below are not present one is consequently safe in concluding that the variable condenser is to blame.

In a case, such as a tuned-grid coupling, where an R.F. choke is effectively in shunt with the tuned circuit, erratic tuning will occur if the choke has a sub-resonance within the tuning range. Such sub-resonances are liable to occur with sectionalised chokes. Each section has a frequency of resonance with its own self-capacity, and there are other such frequencies formed by a combination of sections with the self-capacities. Air-core chokes are particularly prone to this effect because the coupling between the sections is loose enough to permit individual resonances. Iron-core chokes are usually free from it.

The aerial circuit, too, quite often tunes erratically because of the effect of the aerial. This is especially the case on short waves, for the aerial itself is resonant at multiples of its natural frequency. The effect on the tuning of the first circuit, which is coupled to it, is very similar to that of a multi-resonant choke. There is no real remedy, and all one can do is to find the setting for the trimmer which gives the best average results over the band.

WIRELESS SERVICING MANUAL

Below about 1,500 kc/s, however, one can do something because the usual aerial is then below its fundamental resonant frequency. It is the method of coupling to the first circuit which is then so important. Some of the most widely used methods are fundamentally wrong.

Typical coupling arrangements are shown in Fig. 52. With (a) the aerial coil is usually a few turns overwound on the earthy end of the tuning coil—about 10 per cent. of the turns of the tuned winding—while with (b) the aerial tapping is at about the same percentage of turns from the earthy end of the coil. These two circuits are actually identical as far as the R.F. performance is concerned, and they fail chiefly because the fraction of the aerial capacity transferred to the secondary is not a constant, but varies with frequency. It cannot, therefore, be corrected at all frequencies by any adjustment of the trimmer.

The less widely used circuit of Fig. 52 (c) suffers from a similar defect unless the coupling condenser C_1 is so small that the efficiency is very low. A capacity of $25 \mu\mu F$ is often used, but this is much too large for good ganging.

In addition to the ganging difficulties, these circuits also tend towards low efficiency at the low-frequency end of the band and they reduce selectivity excessively at the high-frequency end. They are thus very much of a compromise and consequently are now falling out of use.

There is, however, nothing wrong with the *circuit* of Fig. 52 (a). If the aerial coil is made of much larger inductance than the tuned coil, so that the aerial circuit by itself resonates well below the tuning band, and it is coupled loosely to the tuned winding, results are much better. Such an arrangement is usually known as a "large-primary" tuning circuit.

The effect of the aerial is then to reduce the secondary inductance by an amount which is nearly independent of frequency and which can consequently be compensated by increasing the inductance of the tuned winding. Usually a small error of ganging occurs at the low-frequency end of the band—below 600 kc/s on the medium waveband. In addition, the efficiency is much more nearly constant over the band, and the selectivity at the high-frequency end is improved.

Constructionally, this circuit is easily distinguished from the "small-primary" type, because it is usually made with the aerial coil wound as a narrow pile of many turns spaced one-half inch or so from the tuned winding. Sometimes it is mounted at the grid end of the tuning coil. There is then a small capacity coupling between the aerial and the grid end of the

THE ADJUSTMENT OF GANGING

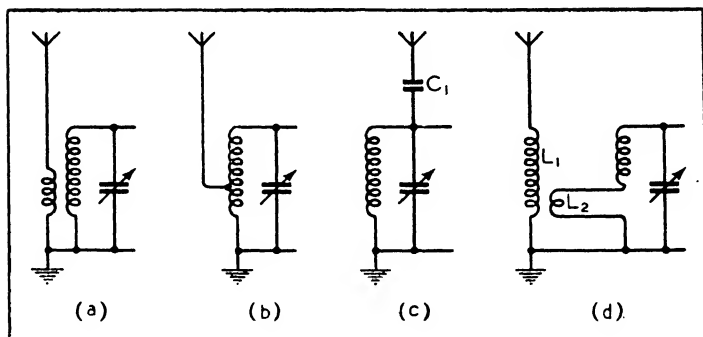

Fig. 52 : The way in which the aerial is coupled to the first tuned circuit greatly affects the ganging of that circuit. The best results are usually obtained with a "large-primary" circuit. This often takes the form (a), but (c) shows a convenient way of adding it to an existing set

coil. This makes the efficiency somewhat better at the high-frequency end of the band, but the ganging is not quite so good.

This type of coupling can readily be applied to an existing set by using a separate coupling transformer as shown in Fig. 52 (d). The author has constructed transformers of this type by winding 600 turns of No. 36 D.S.C. wire on a former of 0.65 in. diameter—the coil being bunch wound to a length of 1 in. A layer of paper over the outside provides insulation, and the secondary L_2 consists of 19 turns of No. 26 enamelled wire as a single layer. An iron-dust core is used. The big coil is used for L_1 of Fig. 52 (d) and the small one for L_2 ; the aerial should be connected to the inside of the big winding.

The total inductance of the tuned circuit is increased by the connection of L_2 , but it is also reduced by the effect of the aerial connected to the primary. The two effects are nearly equal and as a result the transformer can be used with an existing set without much inductance error.

This particular transformer was designed for a super-heterodyne with an intermediate frequency of 450 kc/s, and consequently has a bigger primary than would normally be used with a straight set. The exact resonance frequency of the primary circuit depends on the aerial capacity, but it is of the order of 300 kc/s. For a straight set, one would normally reduce the primary turns to about 400 and obtain slightly higher efficiency.

Mismatched Coils

When the coils are found to be mismatched and they are of the iron-core type, the most probable cause is that one of the cores has changed its position, whereas with an air-core coil the only likely causes are loose turns or short-circuited turns. This last will cause a very large change in inductance.

It is by no means easy to match coils accurately. The measurement of inductance at high frequencies is a tedious process and demands, at the least, a calibrated condenser, a valve voltmeter, and an accurate heterodyne wavemeter and, unless the greatest care be exercised in operating the gear, the results cannot be relied upon to be better than ± 1 per cent. or so.

The most suitable method of measuring inductance for ordinary purposes, where absolute accuracy is unnecessary but only relative accuracy from one coil to another, is undoubtedly a low-frequency bridge. Such bridges are fairly expensive, however.

Matching Ganged Condensers

If the ganged condenser sections are found to be mismatched, and the condenser is of the type having split end vanes, it is possible to rematch it while it is in the receiver by bending the end vanes appropriately. The procedure is to set the condenser so that the first split section is about one-half enmeshed as in Fig. 53 (a) and to gang the receiver accurately. Then set the condenser so that the second split section is just about fully enmeshed as in (b), adjust the oscillator to the receiver and then tune each circuit exactly to the oscillator, not by the trimmers, but by bending the vanes (2) on the condenser appropriately.

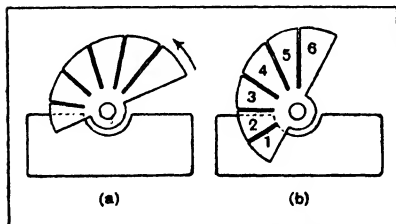

Fig. 53 : A ganged condenser can be rematched by bending the split end vanes appropriately

The operation is best carried out with the aid of an insulated rod, of ebonite or wood, so that hand-capacity effects do not cause difficulty. When the vanes have been bent the right amount the condenser must be further rotated so that the third

THE ADJUSTMENT OF GANGING

section is just enmeshed, the oscillator readjusted to the new frequency and the process repeated. This is done for each segment, and then the ganging readjusted in the usual way by the trimmers at a high frequency.

The process is tedious and not as easy as it sounds, for the vanes have so much spring in them that it is difficult to make them stay in exactly the desired positions. Facility and speed come only with practice.

Although rare in this country at the present time, receivers are sometimes found which include inductance trimmers as well as the usual capacity trimmers, and it is naturally possible to obtain more accurate ganging with such sets, for the coils are automatically matched exactly during the process of ganging.

Two methods of inductance trimming are in use; the first consists of a copper disc which can be moved relative to the coil by a screw adjustment, the second is the provision

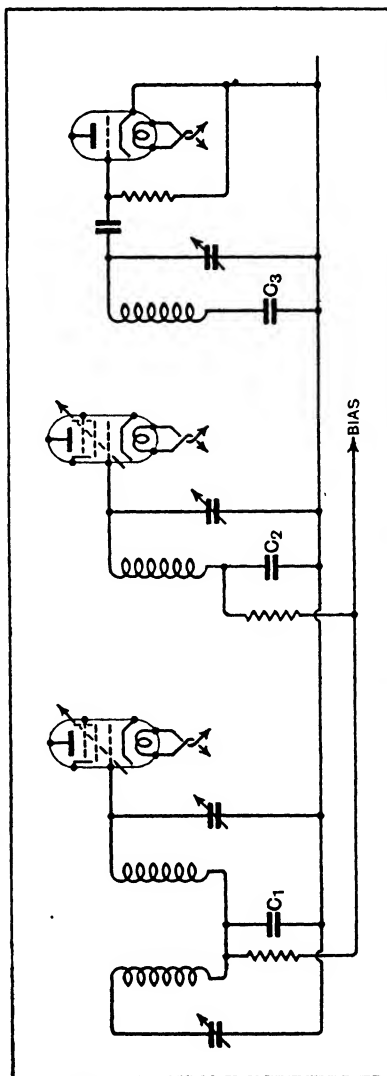

Fig. 54 : For the maintenance of accurate ganging it is necessary that coupling and decoupling condensers be properly proportioned

WIRELESS SERVICING MANUAL

of some degree of movement to an iron-core, again usually by a screw adjustment. Whichever be used, the method of ganging is the same. On the medium waveband, ganging is first carried out at 1,400 kc/s by the capacity trimmers in exactly the same way as with an ordinary set. The oscillator is then set to about 600 kc/s, the set tuned to it, and the inductance trimmers adjusted for maximum response, the actual process being the same as if they were capacity trimmers. It is then necessary to return to 1,400 kc/s and readjust the capacity trimmers.

For the most accurate ganging the process should be repeated until no further adjustments at either frequency give greater sensitivity. In practice, it will usually suffice if the trimming be done twice at 600 kc/s and three times at 1,400 kc/s. In any case, the final adjustments should always be at the higher frequency.

Other Sources of Inaccuracy

Although the chief causes of inaccurate ganging are mismatching of the coils or the ganged condenser, they are not the only causes. An examination of a receiver for these other causes should always be made, for while some sets are straightforward, others may contain several pitfalls for the unwary. In mains receivers fitted with A.V.C. and in most battery sets, the earthy ends of the tuning coils are returned to the earth line through condensers in order that grid bias may be applied to the valves—the general arrangement being as shown in Fig. 54.

Consider the second circuit; the condenser C_2 is necessary partly for decoupling, but chiefly to complete the tuned circuit, which then consists of the coil tuned by the variable condenser in series with C_2 . The presence of C_2 thus reduces the total capacity, for the capacity of two condensers in series is less than that of either alone. It is clear, therefore, that if ganging is to be maintained every tuned circuit in the receiver must include such a condenser whether it is necessary for other purposes or not, and that the capacities of all such condensers must be the same.

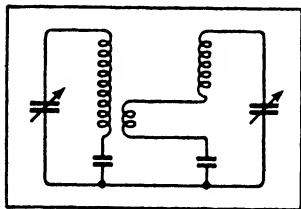

Fig. 55: In a filter coupled by mutual inductance condensers must be inserted if accurate ganging is to be secured

Referring again to Fig. 54, it will be seen that such a condenser, C_3 , is inserted in the detector

THE ADJUSTMENT OF GANGING

tuned circuit in order to maintain accurate ganging and in this circuit it performs no other function whatever.

If the aerial tuning system contained only a single circuit, the condenser to be inserted in this would have the same value as C_2 or C_3 . Where a pair of coupled circuits is used, however, this does not always apply. For a filter coupled by mutual inductance, the condensers of Fig. 55 should have the same values as C_2 and C_3 of Fig. 54, but when a capacity coupled filter is used as in this latter illustration the condenser C_1 must still have the same value as the others. The value of C_1 is decided by the filter coupling required, and for correct ganging C_2 and C_3 must have the same capacity as C_1 .

When testing a receiver, therefore, it is necessary to check these condensers, particularly if the ganging does not hold. An internal short-circuit in C_3 , for instance, would have no other effect upon the performance of a receiver than to upset the ganging and the symptoms would be almost indistinguishable from those associated with an excessive coil inductance in this circuit.

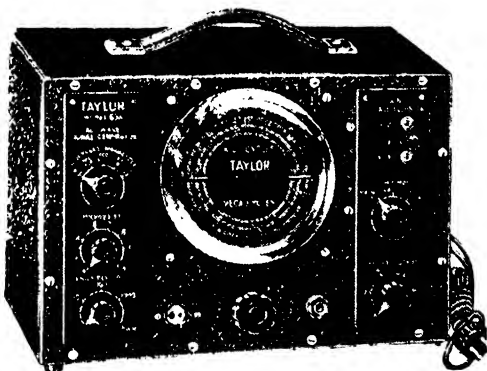

Taylor Model 65A Signal Generator

CHAPTER II

THE ADJUSTMENT OF GANGING— SUPERHETERODYNE I.F. AMPLIFIERS

MOST receivers are now of the superheterodyne type chiefly because of the higher degree of selectivity which is obtainable with such sets. The adjustments are even more important than in the case of straight sets, for incorrect adjustments not only reduce the sensitivity and selectivity but may cause whistles, which are much more noticeable under average conditions. The trimming of a superheterodyne may be divided into two distinct categories—the ganging proper of the signal-frequency and oscillator circuits, and the adjustments in the I.F. amplifier. The latter must always be done before the ganging and will consequently be treated first.

Basically, the trimming of the I.F. circuits is no different from the adjustment of the ganging of a straight set, for a number of circuits has to be tuned, each to the same frequency, by means of trimmers; it is, in fact, easier since the amplifier functions at a fixed frequency and no considerations of maintaining ganging over a waveband enter. The amplifier usually consists of pairs of coupled coils separated by valves, each pair of coils with its trimmers being termed a transformer. Most amplifiers include two transformers, but some have three; in some cases the coupling between the coils is fixed, in others it is adjustable by a sliding coil or pre-set coil, while in still others it can be varied by means of a panel control for variable selectivity.

The frequencies used for I.F. amplification vary greatly. The most widely used are probably 465 kc/s, 456 kc/s, and 450 kc/s, but 110 kc/s, 125 kc/s, 473 kc/s, and 1,600 kc/s are found in some of the older sets. At one time American sets invariably had a frequency of 175 kc/s, but they now usually have a frequency around 450–470 kc/s. It is most important that the I.F. circuits should be adjusted to the correct frequency, for the constants used in the signal-frequency and oscillator circuits depend upon the intermediate frequency. Unless the I.F. amplifier is correctly adjusted to the right frequency therefore, accurate ganging will not be secured.

It can be seen, therefore, that the use of a calibrated test oscillator is much more important with a superheterodyne than with a straight set. The adjustments can be made without it, however, but they are much more difficult. When adjusting

THE ADJUSTMENT OF GANGING

a superheterodyne the first step should be to find out the correct intermediate frequency for that particular set ; it will usually be given in the maker's service instructions or in some of the literature describing the set.

The test oscillator should then be set to this frequency and, if the amplifier is already approximately lined up, its output should be connected between the grid of the frequency-changer valve and the earth line, a fixed condenser or artificial aerial being interposed in the high potential lead for insulation purposes. The output meter should be connected up, and the oscillator output adjusted so that a convenient deflection is secured on the output meter. Each I.F. trimmer must then be adjusted in turn for maximum response, starting with the one on the circuit feeding the detector and working backwards towards the frequency-changer.

If the circuits are widely out of adjustment to begin with, the oscillator output lead should be connected first to the grid of the last I.F. valve, and the trimmers in the last transformer roughly adjusted. The oscillator lead can then be transferred to the grid of the preceding valve and the trimmers on the next transformer adjusted, and so on until the oscillator is connected to the grid of the frequency-changer, when all circuits can be accurately adjusted in the manner already described. As the circuits come into resonance the output increases, and the oscillator output will have to be reduced from time to time to keep the needle of the output meter on its scale.

These adjustments are the basic ones to an amplifier in which the coupling in the transformers is optimum or sub-optimum, and when they have been done nothing further is necessary. When a milliammeter or voltmeter is used as an indicator of resonance instead of an output meter in a set fitted with A.V.C., however, the indications will vary according to the precise arrangement of the A.V.C. system. When the A.V.C. system is fed with the detector from the secondary of the last I.F. transformer as in Fig. 56 (a), the meter will indicate normally during the trimming of both C_1 and C_2 , just as if a true output meter were used. If the A.V.C. system be fed from the primary of the last I.F. transformer, however, as in (b), where C_3 is joined to the anode of the last I.F. valve, the indications are different.

Trimming with a Meter

When a milliammeter or voltmeter is used as an indicator its reading falls as the circuit being tuned comes into resonance,

WIRELESS SERVICING MANUAL

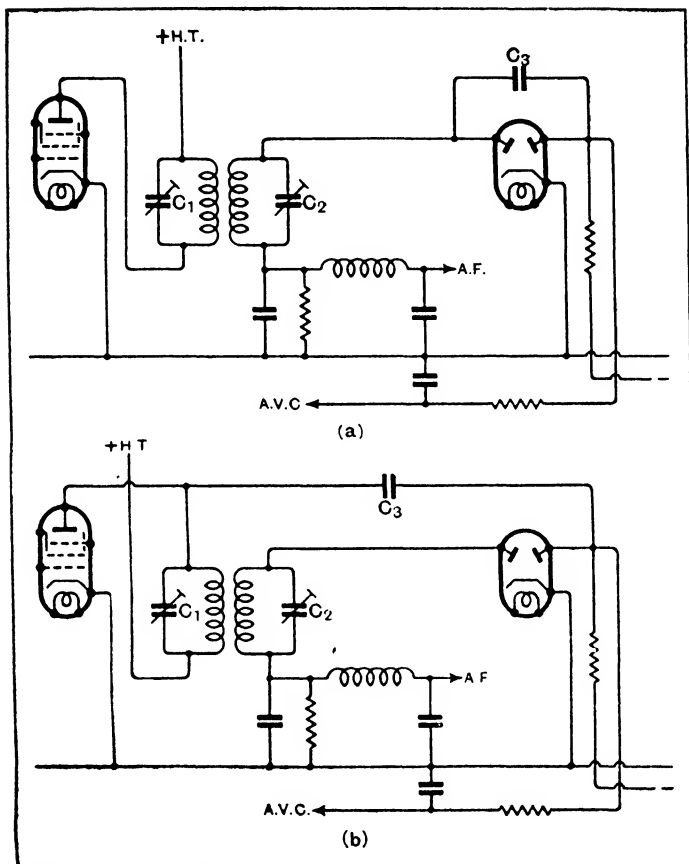

Fig. 56: When the A.V.C. diode is fed from the last transformer secondary (a) a millimeter tuning indicator will indicate resonance for all circuits, but when it is fed from the primary (b) it will not indicate the trimming of C2 properly

and trimming is carried out for maximum change of reading or minimum absolute reading. This holds for all circuits with the arrangement of Fig. 56 (a), but only for the primary and earlier circuits with (b).

Depending upon the degree of coupling used between the

THE ADJUSTMENT OF GANGING

coils in the transformer, trimming the secondary (C_2) will have no detectable effect upon the meter reading, or will cause it to *rise* as the circuit comes into tune. This is brought about by the fact that such a meter merely measures the effect of the A.V.C. bias ; its reading depends upon the input to the A.V.C. diode and not upon the detector input. With the circuit of Fig. 56 (b) the secondary of the transformer is not really in the chain leading to the A.V.C. system, for the tuned circuits affecting this end at the primary.

If there were no interaction between coupled circuits, trimming the secondary could thus have no effect upon the meter reading. In practice, however, the secondary absorbs energy from the primary and it absorbs most when it is tuned to resonance. There is then a smaller voltage applied to the A.V.C. system and the indicating meter rises. When trimming a receiver of this type, therefore, it should be remembered that in the case of the last circuit trimming must be carried out not for minimum reading on the meter but for maximum. Where no change in the meter reading is detectable, the ear must be used as a judge of signal strength.

The use of a proper output meter is very desirable, for it avoids difficulties such as the above. This circuit is by no means an uncommon one ; on the contrary, it is probably more widely used than any other since it tends to reduce sideband screech.

In certain I.F. amplifiers, the coupling between the coils in the I.F. transformers is fixed but it is in some cases greater

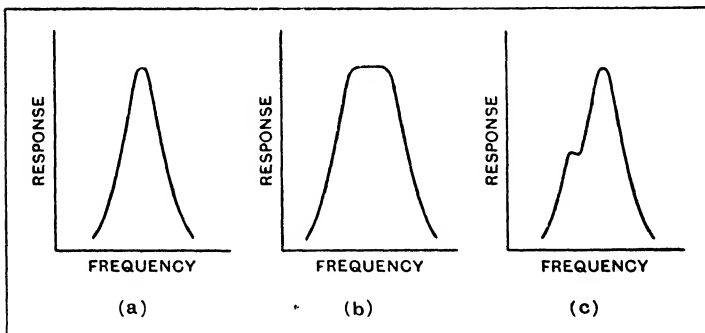

Fig. 57 : The resonance curve of an I.F. amplifier with sub-optimum coupling in the transformer takes the form shown at (a) whereas when tight coupling is used it has a flat top (b). The resonance curve obtained when this type of transformer is not properly trimmed is shown at (c)

WIRELESS SERVICING MANUAL

than optimum. This is done in order that a band-pass effect may be obtained and the resonance curve shall approximate to that of (b) in Fig. 57, instead of taking the form shown at (a). A considerable improvement in the quality of reproduction naturally results from the reduction in sideband cutting. Unfortunately, it is extremely difficult to adjust such amplifiers correctly without elaborate gear or temporarily modifying the set, and the only result of the normal trimming procedure is to produce a response curve of the type shown at (c). Such a resonance curve is very unsatisfactory and causes both low selectivity and distortion; the selectivity, moreover, is greater on one side of resonance than on the other.

The best course with an amplifier embodying transformers of this type is to use a cathode-ray oscilloscope with a frequency-modulated oscillator, for this apparatus permits a picture of the resonance curve to be obtained. If this gear is not available and the amplifier must be adjusted, the best course is to damp the tuned circuits by connecting resistances across them while making the adjustments. The coupling required to obtain a double-humped curve depends on the resistance of the coils. If this is increased sufficiently the resonance curve becomes single-peaked and the circuits can be adjusted by trimming for maximum output in the usual way. The subsequent removal of the damping produces the desired double-peaked curve.

The requisite damping can be added either by increasing the series R.F. resistances of the coils or by reducing the dynamic resistances. The second course is usually much the easier and is less likely to affect the reactances of the circuits. It is done by connecting resistances across the coils while trimming, and if the usual metallised or carbon-type resistances are used, and connected carefully, they will affect the circuit capacity by a negligible amount.

Two courses are possible. Each tuned circuit of a transformer can be damped simultaneously, trimmed in the usual way, and have its resistances removed. Alternatively, one coil only can be damped while the other is trimmed. This necessitates moving the damping resistance from one circuit to the other as the circuits are adjusted alternately. It is, therefore, rather more troublesome, but has two great advantages; the circuit being adjusted is undamped and tunes with its normal sharpness, and stray capacity to the damping resistance does not affect its tuning.

It is, therefore, the better scheme. When dealing with over-coupled circuits connect a resistance across the transformer

THE ADJUSTMENT OF GANGING

primary circuit and adjust the secondary trimmer for maximum output. Remove the resistance from the primary, and connect it across the secondary; then trim the primary for maximum output. Repeat the process, trimming secondary and primary with the resistance across the other circuit, until no improvement can be obtained. Then remove the resistance entirely, and by swinging the test oscillator, check that a symmetrical double-humped resonance curve has been obtained.

The value of the damping resistance required must be found by experiment for it depends on the dynamic resistances of the circuits and their coupling, both of which are usually unknown. The value is not important, however, as long as it is low enough, but if it is too low the sensitivity may be so reduced that an excessive output from the test oscillator is needed. As a rough guide, a resistance of the order of 10,000 ohms is usually satisfactory.

Variable Coupling

Some receivers in which a double-humped type of resonance curve is desired are fitted with transformers in which the coupling between the primary and secondary coils can be varied at will. The adjustment is then much easier, for the transformers are presumably so designed that alterations to the coupling do not affect the tuning. The first step is to loosen the coupling so that by no chance can a double-peaked response curve be obtained, and then to trim each circuit exactly for maximum output in the manner already described. The correct shape of resonance curve can then be obtained merely by adjusting the couplings. In the absence of express instructions to the contrary, the best results will usually be obtained when the coupling in the last transformer—the one coupling the I.F. valve to the detector—is optimum. The coupling adjustment should be moved, therefore, until the output meter reads a maximum or until the loudest signal is obtained.

If the receiver includes only one other transformer, the coupling in this one should be slightly tighter than the value giving the greatest output. If there are two other transformers, however, the first one, which couples the frequency-changer to the first I.F. valve, should be set at just about optimum coupling, while the second which couples the two I.F. valves is set at a value appreciably greater than optimum.

These remarks regarding coupling apply whatever the intermediate frequency as long as it is not higher than about 500 kc/s. With amplifiers tuned to 1,600 kc/s, the coupling should

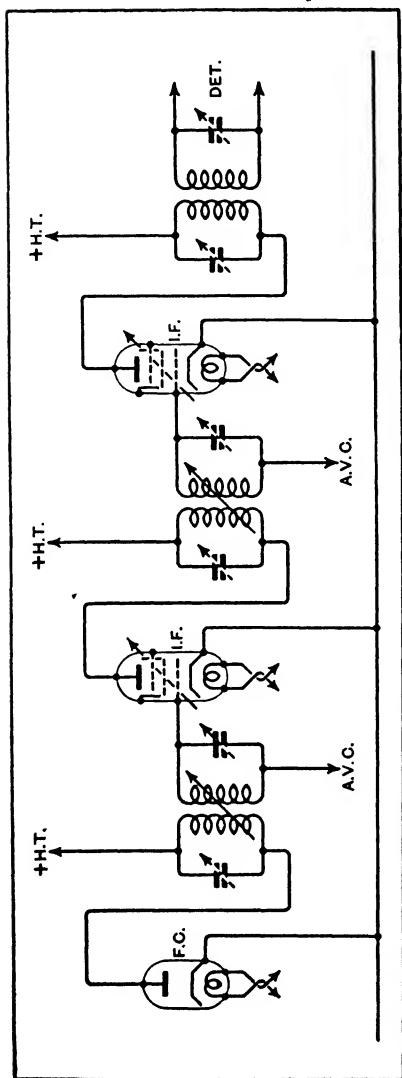

Fig. 58 : A typical amplifier of the variable-selectivity type. The coils in two transformers can have their coupling varied by a panel control

never exceed optimum, and in general, should be appreciably below it.

Some I.F. amplifiers include variable selectivity, the aim being to permit the resonance curve to be varied within limits by means of a panel control so that the optimum compromise between selectivity and quality can be secured under any conditions. A typical arrangement is shown in Fig. 58, and it will be seen that the coupling between the coils of two transformers can be varied while the coupling in the third is fixed, usually at a lower value.

With loose coupling, the resonance curve is of the form (a) of Fig. 59, representing high selectivity. When the coupling is increased the response curve is broadened (b) and the selectivity is lower, but there is less side-band cutting. With the full coupling the resonance curve should be essentially flat-topped (c) and the selectivity quite

THE ADJUSTMENT OF GANGING

low ; this condition is usually only suitable for high-quality local reception.

The adjustment of such an amplifier hardly differs from one with fixed loosely - coupled transformers. The first step is to set the control at maximum selectivity and then to adjust the trimmers for maximum response in the manner already described in detail. It is more

important than with a fixed-coupling amplifier, however, to make sure that each circuit is tuned exactly to resonance, for if any circuit is mistuned the correct flat-topped resonance curve will not be obtained at low selectivity.

When the trimming has been completed, therefore, set the control to low selectivity and swing the oscillator over a range of frequencies on either side of resonance. The output should not vary by more than 2 to 3 db. over the range of frequencies passed by the amplifier. If it should be found that the response

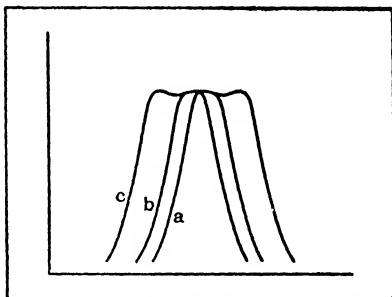

Fig. 59 : The types of resonance curve obtainable with a variable-selectivity I.F. amplifier; (a) high, (b) medium, (c) low selectivity

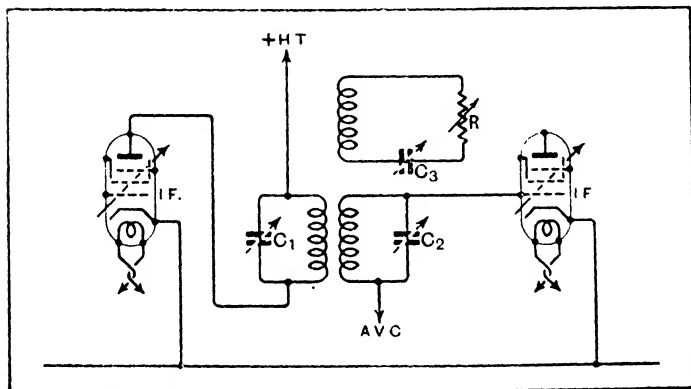

Fig. 60 : A variable-selectivity coupling in which a resistance is used for the control

WIRELESS SERVICING MANUAL

of the amplifier is markedly asymmetrical, the most probable causes are inaccurate trimming, stray capacity coupling between the primary and secondary circuits, or excessive feed-back in the amplifier, and the remedies are obvious.

Another type of variable-selectivity transformer is sometimes used and the connections to one such transformer are shown in Fig. 60. The coupling between the coils remains fixed, and the selectivity is varied by the variable resistance R , being greatest when R is at maximum. To adjust a transformer of this nature, set R at maximum and adjust C_1 and C_2 in the normal way for maximum output. Then set R at minimum and adjust C_3 for *minimum* output.

The purpose of this third circuit is to absorb energy from the main pair of coupled coils and the amount of absorption is greatest when the resistance is lowest. The absorption is also greatest at the frequency to which the circuit is tuned. When R has a very high value, the circuit has little effect, but as R is lowered the circuit absorbs more and more energy, and the absorption increases more rapidly at resonance than at the sideband frequencies, thus tending to give a flat-topped response curve.

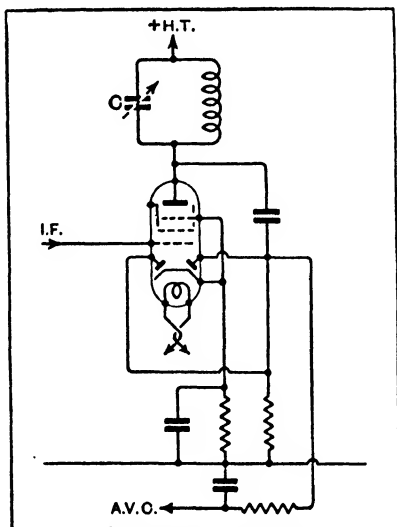
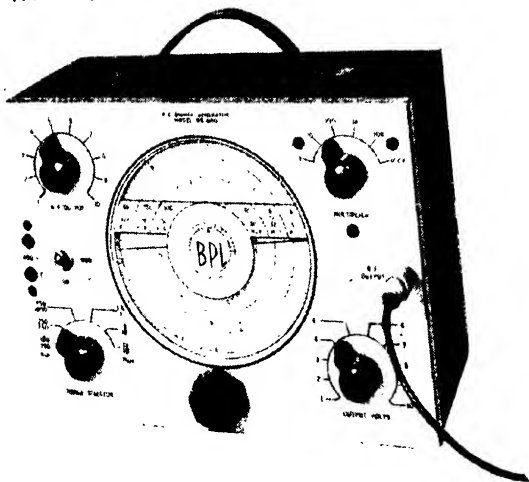

Fig. 61 : An A.V.C. system which includes a circuit tuned to the intermediate frequency

Before concluding the discussion of the I.F. amplifier, mention should be made of a type of A.V.C. system which may need adjustment. The A.V.C. diode is sometimes provided with a stage of amplification of its own which may be fed from the grid of the last I.F. valve, the anode of this valve, or from the detector input. Typical connections for this amplifier are shown in Fig. 61 ; sometimes a choke is used instead of the tuned circuit for the coupling to the diode and then no adjustment is needed.

THE ADJUSTMENT OF GANGING



British Physical Laboratories Signal
Generator, Model RS600



Avo All-Wave Oscillator

WIRELESS SERVICING MANUAL

Sometimes an ordinary I.F. transformer is used for the coupling, and there are then two circuits to adjust. The point of importance is that these circuits cannot be accurately adjusted by means of an output meter, and it is necessary to use a millimeter or voltmeter connected to one of the valves controlled by the A.V.C. system. The trimmer C can then be accurately adjusted for minimum reading on this meter.

When no test oscillator is available, the adjustment of the I.F. amplifier is more difficult, for the exact frequency is unknown. The only course is by trial and error to get the various circuits adjusted in such a way that some signal can be obtained. The I.F. amplifier can then be adjusted in the manner already described and the accuracy of adjustment will be no less than if a test oscillator were used, save that the circuits may not be tuned to the correct frequency. They will be in line with one another, but unless the frequency is correct, the ganging will not hold. It is, however, possible to determine the frequency of an I.F. amplifier fairly accurately by methods which will be dealt with later, and by a process of trial and error to arrive at the correct frequency.

Advance Components R.F. Attenuator with part of the back cut away to show the interior

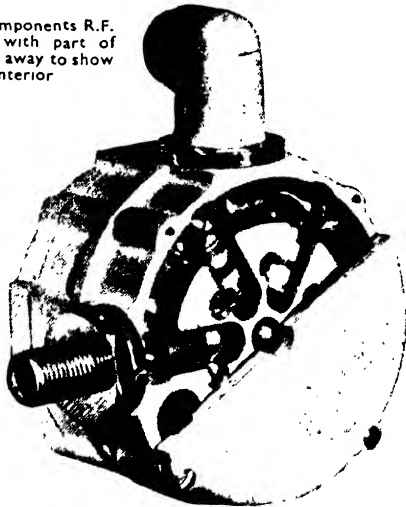

CHAPTER 12

THE ADJUSTMENT OF GANGING— SUPERHETERODYNE SIGNAL-FREQUENCY CIRCUITS

THE ganging of the signal-frequency circuits of a superheterodyne is basically the same as the ganging of a straight set, but is complicated by the fact that there is an oscillator circuit which must at all times be tuned, not to the signal-frequency, but to a frequency different from that of the signal by the intermediate frequency. In all modern superheterodynes the oscillator frequency is higher than the signal frequency, so that for the reception of a station on, say, 1,000 kc/s, the oscillator is set at 1,110 kc/s if the intermediate frequency is 110 kc/s, and at 1,465 kc/s if the intermediate frequency is 465 kc/s.

Thus, while the signal-frequency circuits tune over the range of 550–1,500 kc/s, the oscillator must tune over the band of 660–1,610 kc/s for the low intermediate frequency and over the band of 1,015–1,965 kc/s for the 465 kc/s intermediate frequency. The constants of the oscillator tuning circuit, therefore, are different from those of the signal-frequency circuits, and their precise values depend upon the intermediate frequency used.

There are two different methods of obtaining superheterodyne ganging, but the one now almost universally employed is known as the padding system. With this, the ganged condenser is identical in every way with the type used in a straight set and the difference in frequency between the signal and oscillator circuits is obtained by padding the latter with a combination of fixed condensers and by changing its coil inductance.

Just as in the case of a straight set, the signal-frequency circuits can be represented by the combination of Fig. 62 (a) where L is the tuning coil, C is the variable condenser, and the trimmer C_1 represents the total stray capacity. The oscillator circuit is shown at (b) and is similar save for the introduction of a padding condenser

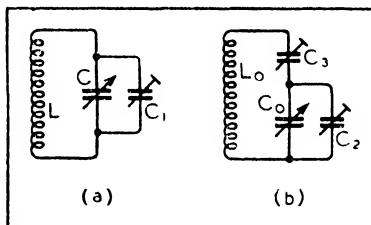

Fig. 62: The basic padding condenser circuit for the oscillator is shown at (b) where C_3 is the padding or tracking condenser, and C_2 is the parallel trimmer. The signal-frequency circuit (a) has only the trimmer C_1 .

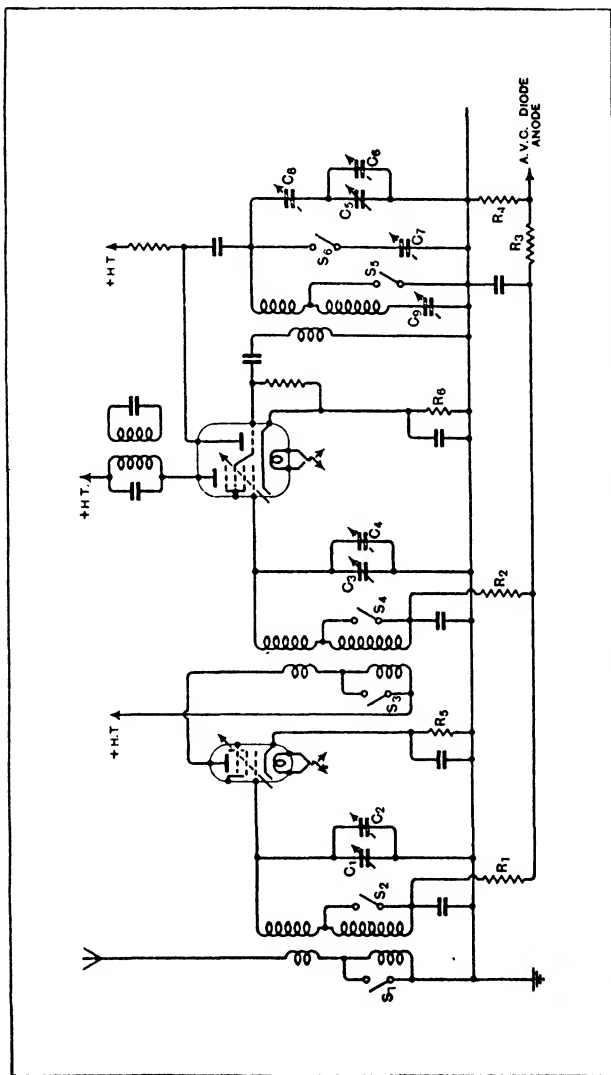

Fig. 63 : The signal-frequency and frequency-changer circuits of a typical superheterodyne showing the ganging arrangements

THE ADJUSTMENT OF GANGING

C_3 in series with the variable condenser C_0 . (The trimmer C_2 is sometimes connected across L_0 instead of across C_0 .) It should be understood that at any dial setting C and C_0 have the same capacity. Now at a high frequency C_3 has little effect upon the total circuit capacity, for it is large compared with C_0 and C_2 ; the correct oscillator frequency is thus secured by the use of a lower value of inductance for L_0 than for L . At a low frequency, however, C_0 and C_2 together are too large to tune this circuit to the correct frequency even with the reduced value of L_0 , so that C_3 is included to reduce the total effective circuit capacity to the correct value. This, in bare outline, is the principle of the padding condenser method of ganging and those interested in the precise mechanism or the calculation of the circuit constants are referred to "Ganging the Tuning Control of a Superheterodyne Receiver," by A. L. M. Sowerby.*

It can be shown that in theory completely accurate ganging is impossible with this system and that the best which can be achieved is for it to be correct at three points in the waveband. At all other points, some errors necessarily exist, the magnitude of which depends upon the total width of the waveband and the value of the intermediate frequency. In design it is the general procedure to legislate for correct ganging at 1,400 kc/s and 600 kc/s on the medium waveband and also at some arbitrary frequency between these values which is usually 800-1,000 kc/s.

Now it is clear that in ganging a superheterodyne the aim is to get all the signal-frequency circuits in resonance with one another just as in a straight set, and by the adjustment of C_2 and C_3 to make the oscillator circuit tune always to the correct higher frequency. The difficulties which arise in practice are brought about by the fact that although it is the oscillator circuit which must be padded to fit the signal-frequency circuits, the tuning is governed entirely by the oscillator for it has the whole selectivity of the I.F. amplifier behind it. Unless a definite procedure be adopted, therefore, ganging may be quite difficult.

There are several ways of tackling the problem and the one adopted depends on circumstances. The one which the author favours has been developed primarily for design purposes in cases where for some reason circuit constants must be experimentally determined, but it also forms the most satisfactory method of adjustment when servicing a receiver. The great advantage of the system is that it avoids any uncertainty; each

* *Wireless Engineer*, February, 1932. See also Appendix I.

WIRELESS SERVICING MANUAL

adjustment can be made precisely and the simultaneous adjustment of two circuits is avoided. In general, however, unless a microammeter be available, the method is only conveniently applicable to receivers which are fitted with A.V.C. and a test oscillator capable of giving an output of up to about 1 volt is also needed.

Consider the typical arrangement of Fig. 63. On the medium waveband the switches S₁, S₂, S₃, S₄ and S₅ are closed, but S₆ is open, whereas on the long waveband the first five switches are open and S₆ closed. The signal-frequency circuit ganging arrangements are no different from those of a straight set and consist merely of the trimmers across the gang condenser sections which are adjusted on the medium waveband. In the oscillator circuit, the trimming condenser C₆ and the padding condenser C₈ have to be adjusted on the medium waveband and the additional condensers C₇ and C₉ on the long waveband. In some cases one of these last two condensers is omitted or is a fixed condenser.

Now it is obvious that the best method of adjustment would be to adjust the signal-frequency circuits on their own, and then to set them at certain frequencies and bring the oscillator into line by adjusting the appropriate trimming condensers. This can only be done, however, if means can be devised whereby the signal itself can be made to give an indication of its presence without in any way necessitating the use of the oscillator. It is possible to do this in a set fitted with A.V.C.

Suppose that the oscillator be prevented from functioning in some way, such as by removing its anode voltage or by short-circuiting its grid or anode coil with a short lead terminating in crocodile clips. The application of a signal will then evoke no response unless the signal has such a magnitude that it overloads the R.F. or frequency-changer valves and they pass grid current in consequence. In any set, the magnitude of the grid current will depend upon the signal strength and it may, of course, be read on a microammeter connected in the grid circuit.

A microammeter is not always available, however, and it is an expensive and delicate instrument, so that it is fortunate that in a set fitted with A.V.C. it is unnecessary. It is clear from Fig. 63 that grid current in either of the two valves must flow through R₃ and R₄. As a result of this current, a potential is set up across these resistances of such polarity that the A.V.C. line becomes negative with respect to the earth line just as if the current through R₄ were produced in the orthodox fashion by the A.V.C. diode.

THE ADJUSTMENT OF GANGING

The potential on the A.V.C. line is naturally communicated to the grids of all valves controlled from the A.V.C. system with the result that their anode current falls. In the same way that a milliammeter connected in the anode circuit, or a voltmeter joined across the bias resistance, of one of the controlled valves can be used as a tuning or ganging indicator, so can such an instrument be employed in the ganging of the signal-frequency circuits of a superheterodyne with the oscillator inoperative.

The ganging of a superheterodyne is thus best carried out in the following manner. Stop the oscillator from functioning by short-circuiting one of its coils, connect a milliammeter or voltmeter to one of the A.V.C. controlled valves in the usual way to act as an indicator, set the variable condenser at minimum, and connect the test oscillator to the aerial and earth terminals. Set the oscillator to 1,500 kc/s and adjust it for full output; then tune to the signal thus applied by means of the signal-frequency trimmers, C₂, C₄ in Fig. 63.

Even if the signal be modulated, no sound will be audible, for the set oscillator is not functioning; the tuning indicator must be relied upon entirely to show resonance. When the trimmers have been adjusted, set the oscillator to 1,400 kc/s, tune the set to it by the main tuning control and readjust the trimmers exactly. Should it be thought desirable, the accuracy of the signal-frequency ganging can now be checked throughout the waveband in the manner described for a straight set.

When the adjustment at 1,400 kc/s has been completed, it is known that in the absence of any defect, the signal-frequency circuits tune correctly and it only remains to line up the oscillator circuit. Leaving the test oscillator at 1,400 kc/s and the signal-frequency circuits tuned to it, reduce its output considerably and make the set oscillator operative by removing the short-circuit on its coils. Then adjust the parallel trimmer (C₆, Fig. 63) for maximum response, which may be read on an output meter if the test oscillator be modulated, or on the milliammeter or voltmeter previously used whether modulation be employed or not.

The setting of this trimmer will normally be quite critical and it may be found that there is more than one point at which the signal occurs. This is particularly likely to be the case with a low intermediate frequency, and especially if the trimmer is of large capacity.

The reason is, of course, that there are two oscillator frequencies which can convert any signal to the intermediate

WIRELESS SERVICING MANUAL

frequency, and if ganging is to be correct, it is essential to choose the right one. In cases where two points of equal response can be found, therefore, always choose the one which requires the lower value of trimmer capacity.

It will sometimes happen that several response points are found of different strengths. These occur through overloading of one of the valves by the test signal and the output of the oscillator should be reduced until only the correct response is found. This correct point is always the strongest.

It is rare for any of these spurious trimming points to occur on the medium waveband, but they are common on short-wave bands and great care must always be exercised to select the correct one.

Having adjusted the parallel trimmer, reapply the short-circuit to the set oscillator, tune the test oscillator to 600 kc/s, and adjust it for large output. Then tune the set to it by the main tuning control, watching for the indication of resonance on the milliammeter or voltmeter, reduce the oscillator output, and remove the short-circuit from the set oscillator. The series padding condenser (C8, Fig. 63) must now be adjusted for maximum response in exactly the same way as the parallel trimmer, choosing the lower capacity setting if two points of response are found.

Since the adjustment of each trimmer in the oscillator circuit affects the setting of the other to some degree, it is advisable to readjust the parallel trimmer at 1,400 kc/s by repeating the process already described for this frequency. It will rarely be necessary to make any readjustment at 600 kc/s, however.

When this process has been carried out—and once the procedure has become familiar it can be done very rapidly—it will be known that the ganging is as accurate as it can be made by adjustments to the trimmers. There must of necessity be discrepancies at some points in the tuning range, the magnitude of which for the normal tuning range depends solely on the intermediate frequency.

Nothing can be done to reduce these normal errors, but it should not be forgotten that they will be greatly increased by an incorrect ratio of signal to oscillator coil inductance or by the use of an incorrect intermediate frequency.

On the long waveband, the adjustments are similar to those on the medium waveband, save that there are sometimes no adjustments required by the signal-frequency circuits. When the trimming condensers are as in Fig. 63, tune the set to the test oscillator in the usual way with the set oscillator inoperative

THE ADJUSTMENT OF GANGING

and the test oscillator set to 300 kc/s ; then reduce the output, remove the short-circuit from the set oscillator and adjust the parallel trimmer (C7) for maximum response.

Then repeat the process at 160 kc/s, this time adjusting the series padding condenser C9. If the receiver has no parallel trimmer, only the series trimmer can be adjusted, and it is usually best done at 160–200 kc/s. If the set has no adjustable series padding condenser, but only a parallel trimmer, this is best adjusted at about 250–300 kc/s.

The alternative and more usual ganging procedure does not require that the set oscillator be periodically thrown out of action, or that the set be fitted with A.V.C. It is, however, somewhat more difficult to carry out and more likely to lead to ambiguous results, although it is superficially easier. The procedure is to set the test oscillator to 1,400 kc/s with modulation and connected to the aerial and earth terminals of the set.

An output meter is the best tuning indicator, but if the set has A.V.C., a milliammeter or voltmeter can be used. If the receiver has a wavelength or frequency calibrated dial, set the tuning control appropriately for 1,400 kc/s (= 214 metres) and adjust the oscillator parallel trimmer (C6, Fig. 63) for maximum response, and follow by adjusting the signal-frequency trimmers.

If the receiver is not calibrated, it will be necessary to make a guess at the appropriate trimmer settings, then to tune the set to the signal by the main tuning control, and finally to adjust the signal-frequency trimmers.

The test oscillator is then set at 600 kc/s and the set tuned to it by the main tuning control. The series padding condenser is then adjusted while rocking the gang condenser backwards and forwards over a few degrees by the tuning control until the optimum combination of settings is found. A return is then made to 1,400 kc/s and the signal-frequency trimmers readjusted.

On the long waveband, the parallel oscillator trimmer should be adjusted first at 300 kc/s while rocking the tuning control until the best combination of settings is found. The series padding condenser can then be adjusted in the same way but at 160 kc/s.

Quite good results can be secured with this procedure, particularly when it is merely a case of readjusting the ganging of a set which has been in use for a time and which is already presumably approximately ganged. In such cases, the adoption of the more accurate procedure may be unnecessary, but with a set which is widely out of adjustment it is to be recommended

WIRELESS SERVICING MANUAL

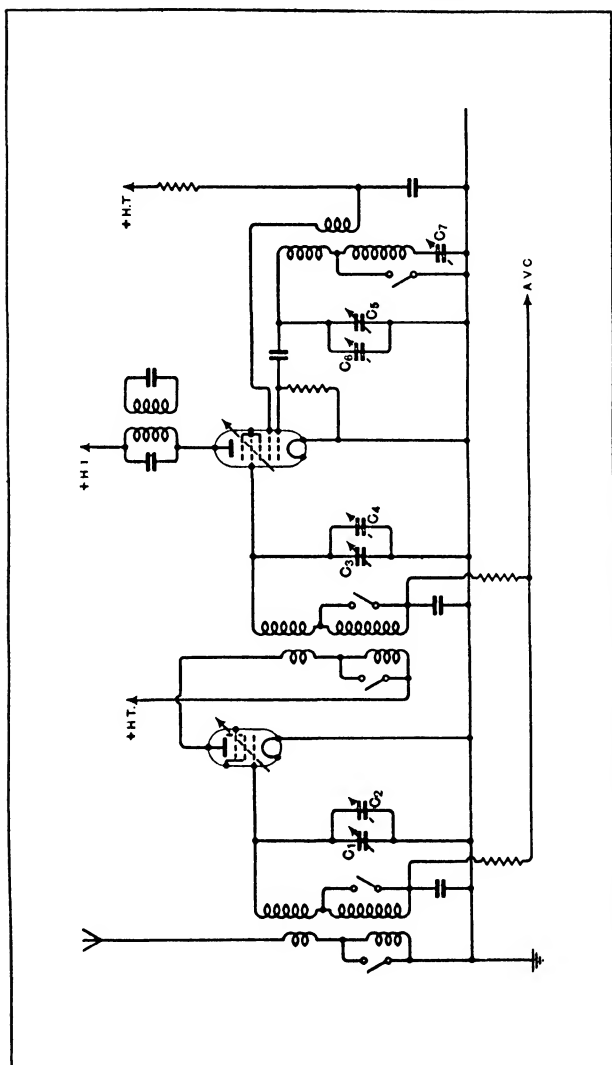

Fig. 64 : When a "shaped-plate" ganged condenser is used, the ganging arrangements are as shown here

THE ADJUSTMENT OF GANGING

as being more exact and probably more rapid because it avoids any ambiguity. Great care should be taken to see that the oscillator frequency is always higher than the signal-frequency.

Difficulty is unlikely in most cases where the series padding condenser consists of a small capacity pre-set condenser in parallel with a fixed condenser. Where a large capacity pre-set condenser is used, however, and the intermediate frequency is low, it is quite possible so to adjust the circuits that at 600 kc/s the oscillator is higher than the signal-frequency, whereas at 1,400 kc/s it is lower.

The ganging cannot possibly hold over the waveband under such circumstances and the performance of the set will be very poor indeed in regard to sensitivity and its liability to second channel interference, except at the two extremes of the waveband.

The Adjustments with a Superhet Condenser

The second system of ganging which is employed in some of the older receivers necessitates no padding condenser for the medium waveband. A special gang condenser is used, having ordinary sections for the signal-frequency circuits but for the oscillator a section in which the vanes are differently shaped so that correct tracking is automatically secured.

The precise shape of the vanes depends upon the value of the intermediate frequency, the stray circuit capacities, and the relative value of the signal and oscillator circuit coil inductances, as well as the tuning range. A condenser which has vanes cut to suit an intermediate frequency of 110 kc/s, therefore, is unsuitable for a frequency of 465 kc/s, and it would be unwise to use it with a frequency of 120 kc/s, although the errors would then naturally be smaller. On the long waveband the tracking does not hold, and it is necessary to introduce a padding condenser.

A typical circuit diagram is shown in Fig. 64 ; on the medium waveband all switches are closed and ganging is best carried out at 1,400 kc/s by adopting the procedure already described for the adjustment of the padding system at this frequency. If this procedure be adopted, which means setting the signal-frequency circuits exactly to 1,400 kc/s with the set oscillator inoperative and then trimming the oscillator condenser C6 ; no other adjustments are needed on the medium waveband.

This method may not always be possible, however, and then it is necessary to proceed rather differently. The oscillator trimmer C6 should be set about half-way ; the test oscillator

WIRELESS SERVICING MANUAL

should be at 1,400 kc/s, and it should be tuned in by the main tuning control, and the signal-frequency trimmers, C₂, C₄ adjusted for maximum response. The test oscillator should then be set at 600 kc/s, and the set tuned to it. The oscillator trimmer can then be adjusted while rocking the tuning control backwards and forwards over a few degrees until the optimum combination of settings is found.

A return must next be made to 1,400 kc/s and the signal-frequency circuits readjusted as before. The oscillator trimmer must then be readjusted at 600 kc/s and then the signal-frequency circuits at 1,400 kc/s, and so on, until no further adjustment at either frequency improves the performance.

On the long waveband, the ganging is no different from that with the padding system, for it is actually the same method of achieving tracking. It is not necessary, therefore, to treat this case again.

The special gang condenser system of ganging is now rarely used, for it is essentially a method for one waveband only, although by the addition of padding it can be made to work on two. Most modern sets have at least three wavebands and the padding system is then much more suitable.

Although not commonly found, it may be as well to describe the adjustments necessary in sets having inductance as well as capacity trimmers. The large number of trimmers is apt to be somewhat frightening at first, but if their adjustment is tackled systematically, the presence of the inductance trimmers will be found actually to help matters. This is because the possibility of mismatched coils is removed; it is always possible to obtain correct ganging merely by adjusting the trimmers.

The procedure will be described in relation to the medium waveband, but it is of course exactly the same on any other waveband, the adjusting frequencies being proportionately related to the limiting frequencies of the band.

A typical circuit is shown in Fig. 65 and it will be assumed that it is necessary not only to gang the set but to adjust its frequency coverage to a given band—say, 550–1,500 kc/s. It is necessary to adopt the technique of adjusting the signal-frequency circuits with the mixer driven into grid current, so that a test oscillator with ample output is needed.

Short-circuit the set oscillator coil, set the tuning condenser to minimum and the test oscillator to 1,500 kc/s. Using a large output from the test oscillator and a meter to indicate resonance in the manner previously described, adjust the signal-frequency trimmers C₂ and C₄ for maximum response. Then set the

THE ADJUSTMENT OF GANGING

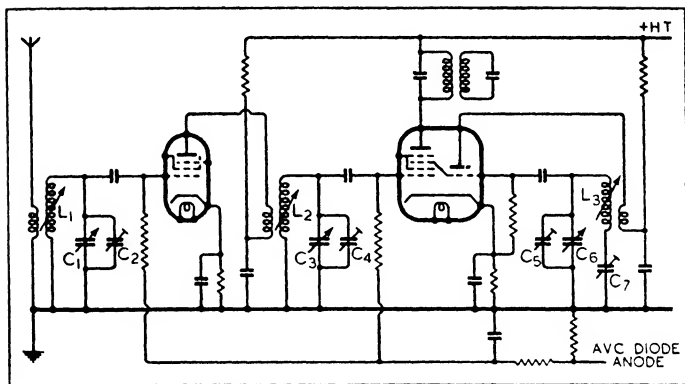

Fig. 65 : The most accurate ganging is obtained when the inductances are adjustable as well as the circuit capacities. The detailed ganging drill for this condition is given in the text

tuning condenser to maximum and the test oscillator to 550 kc/s, and adjust L_1 and L_2 for maximum response.

Now go back to 1,500 kc/s and readjust C_2 and C_4 . Repeat the process, adjusting alternately at 550 kc/s and 1,500 kc/s until no improvement can be secured. Adjust the capacity trimmers only at 1,500 kc/s and the inductance trimmers only at 550 kc/s, and finish by adjusting the capacity trimmers.

When this has been done the signal circuits are not only in track with each other, but cover the required band of frequencies. It is now necessary to gang the oscillator circuit to the signal circuits, and one must remember that the parallel trimmer C_5 controls the tracking chiefly at the high-frequency end of the band while the padder C_7 and the inductance L_3 control it at the low-frequency end and at the middle respectively.

Set the test oscillator to 1,400 kc/s and tune the set to it by the tuning control. Reduce the input to the set and remove the short-circuit from the set oscillator. Adjust C_5 for maximum output. Replace the short-circuit on the set oscillator, increase the test oscillator output and tune it to 970 kc/s. Tune the signal circuits to it, reduce the test oscillator output, and remove the short-circuit from the set oscillator. Adjust L_3 for maximum output. Replace the short-circuit on the set oscillator, increase the output of the test oscillator and set it to 600 kc/s.

WIRELESS SERVICING MANUAL

Tune the set to it, reduce its output and remove the short-circuit from the set oscillator. Adjust C7 for maximum output.

The adjustments are now very roughly correct, but it is necessary to repeat them several times to get them exactly right for they are all interdependent. The best way now is to leave L3 alone for the time being and to adjust C5 and C7 alternately as previously described for a set with a fixed value of inductance. Never forget that C5 must be adjusted only at 1,400 kc/s and C7 only at 600 kc/s, and always finish with C5.

When no further adjustments to these two improve matters the tracking is correct at 1,400 kc/s and 600 kc/s. It is also correct at one frequency between. What this frequency is depends on the value of the inductance. There is an optimum value for this frequency which makes the inevitable errors at other frequencies a minimum. The next step, therefore, is to adjust L3 correctly.

To do this, the test oscillator is set to 970 kc/s and the signal circuits tuned to it in the usual way. The set oscillator is made operative again, and L3 adjusted for maximum output. Then leave L3 alone again, and readjust C5 and C7 at 1,400 kc/s and 600 kc/s alternately until they are again both correct at these frequencies. Keep repeating the process of adjusting L3 at 970 kc/s, followed by C5 at 1,400 kc/s and C7 at 600 kc/s alternately, and always ending with C5, until no further adjustments improve matters.

The process is not nearly as difficult or lengthy as it sounds. In general, for each adjustment of L3, it is not usually necessary to adjust C5 more than three times and C7 more than twice. It will also be unusual if L3 has to be adjusted more than three times. If the set is not badly out of alignment to start with, of course, many fewer adjustments will be needed.

Although not yet widely used in broadcast equipment, inductance trimming will probably become much more common in the future. Not only does it result in improved performance because better ganging is secured, but it eliminates the necessity for the accurate matching of coils in the factory. In these days of iron-dust cores for coils, it is very easily arranged.

There is a further class of adjustments which, while hardly ganging, are conveniently dealt with at this point. Some receivers include a wavetrap in the aerial circuit tuned to the intermediate frequency for the purpose of eliminating the direct pick-up of signals of this frequency. A wavetrap of this type is dignified by various names such as L.F. trap or I.F. interference suppressor, but it invariably takes one of the two

THE ADJUSTMENT OF GANGING

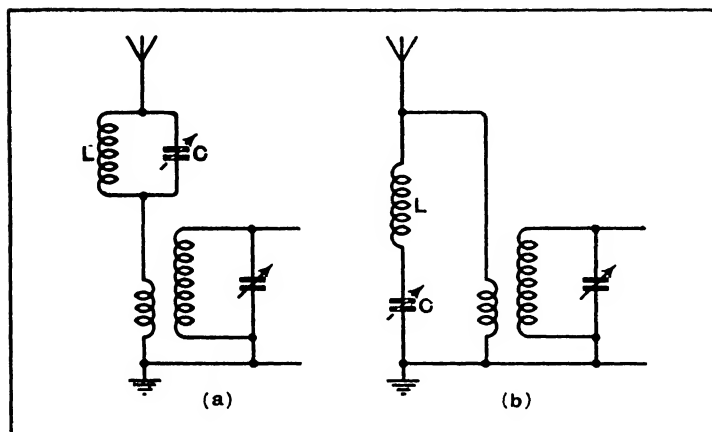

Fig. 66 : Wavetraps in the aerial circuit are sometimes used to prevent the break-through of signals on the intermediate frequency. A rejector is shown at (a) and an acceptor at (b)

forms shown in Fig. 66, where the coil and condenser forming the wavetraps are designated by L and C. Whichever circuit be used, the adjustment is the same. In general, (a) is used with "small-primary" aerial coils and (b) with "large-primary" types.

The test oscillator should be connected to the aerial and earth terminals and set to function at the intermediate frequency, the output control being set so that some output from the receiver is obtained. The trimming condenser C is then adjusted for *minimum* output.

Some receivers, either as well or instead, include one or two wavetraps of similar nature which are intended to be tuned to the local station in order to prevent the formation of whistles through the overloading of early valves by such strong signals.

These circuits can be adjusted by means of the test oscillator in the same way as an I.F. trap, but using the appropriate frequencies and tuning the set to the oscillator. In general, however, it is better to perform this adjustment upon a signal, the procedure being to tune the set to the local station and to adjust the appropriate trap condenser for *minimum* response.

Before concluding, it may be as well to remark that the defects which may occur in a superheterodyne and which prevent

WIRELESS SERVICING MANUAL

proper ganging are essentially the same as those which are found in a straight set. Incorrect values of stray circuit capacity, wrong values of decoupling condensers in A.V.C. circuits, bad matching of the condenser sections, wrong coil inductance, all apply with equal force. In addition, the use of the wrong value of intermediate frequency will prevent proper ganging.

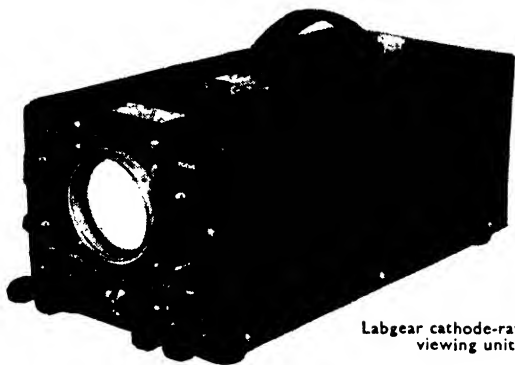

Labgear cathode-ray tube
viewing unit

CHAPTER 13

TRACING THE CAUSE OF WHISTLES

AMONG the various faults which may occur in a wireless receiver, few are more troublesome to trace and cure than those which give rise to whistles. The difficulty in finding a cure which does not seriously affect the performance in other ways is brought about by the fact that, while it is generally easy enough to find out to which of the main types any particular whistle belongs, it is by no means easy to determine its precise cause.

As in every other trouble which may occur, diagnosis must be carried out scientifically if it is to be accurate. The symptoms will suggest a particular cause: the cause will suggest certain tests which will confirm or disprove it; the results of these tests will suggest others, and so on.

The various whistles which may be met with are most conveniently divided into categories according to the symptoms which they produce. The three chief types are:—

- (1) whistles which do not vary either in pitch or intensity with the tuning;
- (2) whistles which vary only in intensity with the tuning;
- (3) whistles which vary in both pitch and intensity with the tuning.

In most cases, any given whistle can immediately be placed in one of these categories, and the search for its cause correspondingly limited.

Considering first the case of those whistles which are independent of tuning, they are almost invariably due to A.F. regeneration. If sufficient feed-back exists in the low-frequency amplifier and it is in the right phase, self-oscillation will occur at a frequency dependent upon the characteristics of the circuits. When oscillation takes place at a very low frequency it is called motor-boating, and this is treated in detail in another chapter.

At higher frequencies, however, the symptoms are in the form of a continuous note which is usually of high enough frequency to be called a whistle. The frequencies most usually found lie between 1,000 c/s and 5,000 c/s, but in some cases may be higher and even above audibility; their presence may not then be suspected.

With modern high-quality apparatus true whistles are usually of fairly high frequency and due to capacity coupling between

WIRELESS SERVICING MANUAL

the input and output circuits. Consequently they rarely, if ever, occur in apparatus in which the receiver and amplifier are built on a single chassis, except when a pick-up or microphone is being used, for the designer has taken precautions in the construction against such feed-back. Where the amplifier is a separate unit, however, feed-back is quite probable if the various connecting leads are carelessly arranged.

The Loudspeaker Leads

The proximity of the loudspeaker leads to the input connections, for instance, may easily cause instability, particularly at very high frequencies and particularly if the amplifier has a very good frequency response characteristic. Even if the feed-back is insufficient to cause instability, it may affect the characteristics of the amplifier.

Such feed-back can easily be cured by separating the leads sufficiently, and where this is impracticable by screening them. The screening should, of course, be earthed and when fitting up an amplifier it is a wise plan to instal it at the start since it also reduces the possibility of hum pick-up in the leads.

A whistle of this character is unlikely to develop with use in a modern mains-operated receiver; it is either present initially or not at all. The case is different with a battery set, however, particularly those of the older variety using A.F. transformers of doubtful characteristics. Judged aurally, the whistle is of similar character to that brought about by stray-coupling between the input and output circuits, and may in fact be actually due to this. More often, however, it is due to nothing more than a partially run-down H.T. battery.

The internal resistance of an H.T. battery is quite low when it is new, and little feed-back occurs between the different stages even when decoupling circuits are omitted. When the battery begins to age, but long before it is due for the scrap-heap, its internal resistance rises and appreciable feed-back may occur in the receiver. When actual instability results the frequency of the whistle produced depends upon the characteristics of the apparatus, and except when the frequency is low the connection of a 2 μ F condenser across the H.T. battery will often effect a cure.

Decoupling the Anode Circuits

The proper remedy, however, is to decouple the various anode circuits. Feed-back of this nature is really the same as that which produces motor-boating in a mains set, the different

TRACING THE CAUSE OF WHISTLES

symptoms being due mainly to the different nature of the impedance of the H.T. supply. It is worthy of note that a run-down grid bias battery may sometimes produce similar effects, as also may a faulty battery cable or a dirty wander plug.

A whistle of comparatively low pitch, which is more commonly called a howl, may occur through a microphonic valve. The howl usually builds up slowly, and is often set up by a loud passage of music. The offending valve is easily located by tapping all the valves gently; the noise resulting from tapping the offender will leave one in no doubt whatever that one has found the guilty specimen. If a non-microphonic valve cannot be secured, the only remedy is to mount it in an anti-microphonic valve holder or to mount the whole chassis on sponge rubber.

A fault of similar character which occurs only on radio may be due to a defective valve in the pre-detector circuits. In general, however, the howl builds up very gradually and is of quite low frequency; moreover, it only occurs in selective receivers and is more noticeable on the medium waveband than on the long. It is then usually due to acoustic feed-back from the loudspeaker to the vanes of the variable condenser and it is a defect which is particularly likely to occur in short-wave receivers.

The fault is one which is not always easy to cure when the receiver and loudspeaker are in the same cabinet. The first thing to do is to isolate the condenser from any vibration which may be conveyed mechanically by the chassis and cabinet. This may often be done by suspending the receiver chassis on blocks of sponge rubber so that it can float freely.

Sometimes it is more convenient to mount the condenser on the chassis in a similar manner, and sometimes both mountings are necessary. The tuning dial must, of course, be arranged to float with the condenser, otherwise the suspension is useless. The effects of the direct radiation from the loudspeaker can sometimes be nullified by enclosing the variable condenser in a box stuffed with cotton wool, but this is often difficult to arrange.

Vibrating Condenser Vanes

In extreme cases, it may be necessary to replace the variable condenser by one having vanes less susceptible to vibration. The materials used in the construction of the condenser have a big effect upon its performance in this respect. It is often stated that brass vanes are superior to aluminium from this point

WIRELESS SERVICING MANUAL

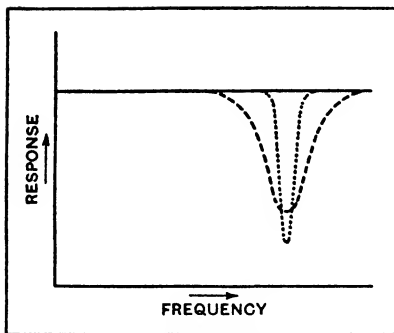

Fig. 67 : The introduction of a tuned whistle filter ideally changes the response of the receiver from the form of the solid line curve to that of the dotted curve, but in practice the response is more likely to take the form of the dash-line curve

of view, but this is not necessarily the case. Actually, a condenser with vanes of soft aluminium is likely to be better than one in which hard brass has been used, and the author has obtained the greatest freedom from this form of feed-back with condensers having zinc vanes. The requirement is that the vanes be heavily damped so that they do not vibrate easily, and this is most likely to be

found in condensers having vanes of soft metal.

The second class of whistles, those which vary in intensity but not in pitch with the tuning, are rarely, if ever, due to the receiver. These whistles are the beats formed between adjacent stations and are inevitable if the receiver is capable of reproducing the frequencies involved. Broadcasting stations are usually spaced by 9 kc/s, so that if the receiver will reproduce frequencies of this order, a 9,000 c/s whistle is inevitable. High quality reproduction demands frequencies up to 10,000 c/s, so that trouble of this type is more likely to be met with in modern high-fidelity apparatus than in older sets which do not pretend to give a full high note response.

Whether or not such a whistle is met with in a high quality receiver depends entirely upon the relative strengths of the stations involved. If both stations are of the same strength the whistle will be prominent, whereas if the set is tuned to the local station and its neighbour is quite weak, the whistle may not be audible.

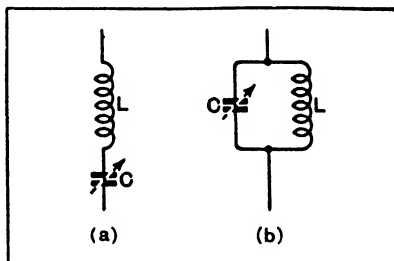

Fig. 68 : The acceptor type of whistle filter is shown at (a) and the rejector type at (b)

TRACING THE CAUSE OF WHISTLES

It is important to remember that it is impossible to prevent such whistles from occurring without adversely affecting the quality of reproduction. If a set does not reproduce them, then it is certain that the receiver or loudspeaker is deficient in the extreme treble. Conversely, if they are present, one has the satisfaction of knowing that there is little wrong with the high frequency response of the apparatus.

It is generally found, however, that the whistle is objected to more than the slight deterioration in quality which accompanies its removal. It is necessary to adopt the proper remedy, however, if the effect on quality is not to be serious and most emphatically the proper remedy is not to shunt intervalve couplings with condensers nor to make use of the conventional tone control. In order to remove a 9,000 kc/s whistle, an attenuation at this frequency of at least 20-30 db. is needed, and this cannot be introduced by such simple means without attenuating seriously all frequencies down to about 3,000 c/s and so making the reproduction intolerably muffled. The proper remedy is to include either a correctly-designed low-pass filter or, more simply, tuned rejection circuits.

The low-pass filter is not a general solution, for the filter constants will vary somewhat with different receivers depending upon the circuit impedances. Moreover, it is both bulky and expensive. If it be used, it should have a cut-off frequency of about 7,500 c/s and a frequency of infinite attenuation at

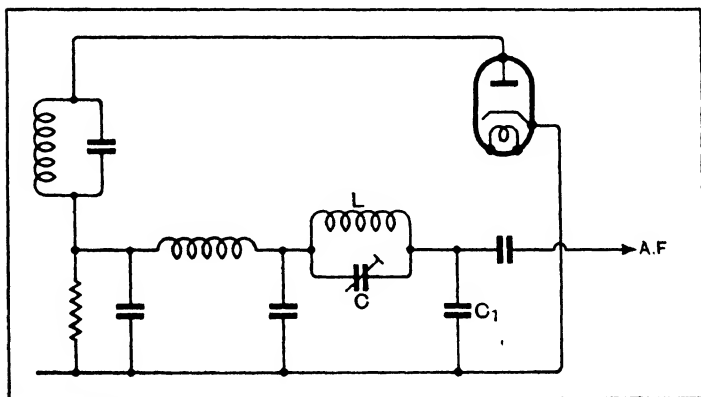

Fig. 69 : The connection of a rejector circuit after a diode detector :
C1 should be about 0.0001 μ F

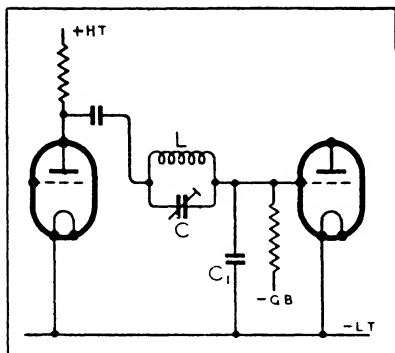

Fig. 70 : In an intervalve circuit the trap should be connected in series with the coupling condenser

9,000 c/s. For general use, a tuned circuit is likely to be of more value; this can be of either the acceptor or rejector type and is really identical, save in constants, with the wavetrap commonly used at signal frequency.

If the response curve of the receiver is of the form shown by the solid curve of Fig. 67, then the insertion of the trap circuit would ideally change the response to

that shown by the dotted curve, introducing great attenuation at the whistle frequency, but hardly affecting other frequencies. In practice, the response obtained is more of the form of the dash-line curve.

The two types of filter, acceptor and rejector, are shown in Fig. 68; the acceptor circuit (a) is connected in parallel with an intervalve coupling or output transformer, whereas the rejector (b) is connected in series. The values assigned to the components depend upon the frequency of the whistle, the amount of attenuation required, the amount of attenuation permissible at other frequencies, and the impedance of the circuits with which the trap is used.

If each circuit is adjusted to give the same attenuation at resonance and the coils are of the same efficiency, there is nothing to choose between the two in the matter of performance. For good attenuation a high $Q (= \omega L/R)$ is needed, and this is quite difficult to obtain, for the inductance required is so large that small diameter wire must be used to keep the coil reasonably compact. In order to secure adequate attenuation, therefore, it is often necessary to permit more attenuation at other frequencies than one would like.

In the case of the acceptor circuit, this means using a comparatively low value of inductance and large capacity, whereas with the rejector circuit a high inductance and small capacity is indicated. Now the capacity must be variable in order to permit the circuit to be tuned exactly to the whistle and it is easier to obtain a small variable condenser than a large one.

TRACING THE CAUSE OF WHISTLES

In general, therefore, the rejector circuit is the more useful of the two.

The connections for such a rejector in the output circuit of a typical diode detector are shown in Fig. 69, and in the case of an intervalve circuit in Fig. 70. The value of the grid leak resistance or volume control which follows the trap should be about 0.25 megohm when the usual values for the trap constants are employed. The filtering action is greatly increased if the condenser C_1 be included after the trap. The usual values are $L = 0.8$ H, $C = 0.0005$ μ F max., for a frequency of 9,000 c/s. For other frequencies both L and C should be changed, and should be inversely proportional to frequency; thus, for 4,500 c/s, both inductance and capacity should be doubled.

It may be remarked that the position of these components in a set should be chosen with care, for as the coil contains many turns it can easily pick up hum if it is too near a mains transformer. It should, therefore, be kept well away from any components which are likely to produce a stray magnetic field.

Taylor Model 90A Multi-Range Test Meter

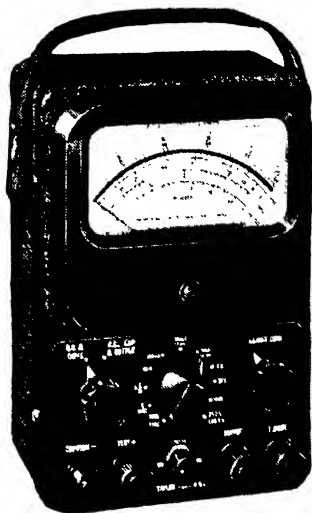

CHAPTER 14

SUPERHETERODYNE WHISTLES

THE last and most important class of whistles contains all those which vary in both pitch and intensity when the setting of the tuning control is altered. The whistles caused by instability actually come into this category, but this trouble is dealt with in another chapter. There is rarely any difficulty in deciding whether a receiver is unstable or not, for instability gives other symptoms than whistles. The whistles discussed in this chapter can occur only in superheterodynes and are commonly called second channel or image interference, although this is actually only one out of many possible causes.

The remedies for the different types of whistle which may occur naturally vary with their cause, and it is necessary to be able to distinguish them in order to apply the appropriate remedy. This is not always easy, for the only audible difference between some of the whistles is that the rate of change of pitch for a given movement of the tuning control is different for some whistles than it is for others, and in some cases there is no difference at all. It is essential, therefore, to understand how the whistles arise in order to apply the appropriate tests intelligently.

Second channel or image interference is the best known, but not always the most important, source of whistles. It arises in this manner. In order to receive a given station, the oscillator is set to work at a frequency higher than that of the station by the intermediate frequency. The intermediate frequency is, in fact, the difference between the signal and oscillator frequencies.

Normally, operation is carried on with the oscillator at a higher frequency than the signal, for this leads to convenient ganging, but it is not essential to the process of frequency-changing, and the oscillator might equally well be lower than the signal frequency. In actual fact, with the present crowded condition of the ether, although the oscillator frequency is higher than that of the wanted signal, there is always some other signal at a frequency higher than that of the oscillator by an amount roughly equal to the intermediate frequency.

Thus, suppose the intermediate frequency is 110 kc/s; for the reception of a station A on 1,000 kc/s, the oscillator will be functioning at 1,110 kc/s. Now if there is a station B on

SUPERHETERODYNE WHISTLES

1,220 kc/s, there may be interference. If both signals A and B are handed on to the frequency-changer there certainly will be interference, for the frequency-changer cannot distinguish between them—both are separated from the oscillator by 110 kc/s and both will be changed to this frequency and pass through the I.F. amplifier. There will be no whistle, however, for both stations produce a frequency of 110 kc/s exactly.

How a Whistle is Produced

Suppose the tuning to be changed slightly, however, so that the oscillator is at 1,111 kc/s. Station A will now produce an intermediate frequency of 111 kc/s, and station B one of 109 kc/s. Both will still pass through the I.F. amplifier, but there will now be a whistle of 2 kc/s. Thus mistuning the set by 1 kc/s has produced a whistle of 2 kc/s, and it may be said that the pitch of the whistle produced by second channel interference changes its pitch for a given movement of the tuning control twice as rapidly as does the whistle produced by an oscillating detector set.

A whistle is produced if station B is not separated from station A by exactly this amount. Suppose the oscillator is set at 1,110 kc/s for the correct reception of A, and it produces an intermediate frequency of 110 kc/s from this station. Then if station B has a frequency of 1,218 kc/s, it will produce in the frequency-changer a frequency of $1,218 - 1,110 = 108$ kc/s. This will pass through the I.F. amplifier along with the correct frequency of 110 kc/s produced by A and in the detector a beat of $110 - 108 = 2$ kc/s will be produced.

There are many other possible causes of whistles, among which the following are the most important:—

I.F. Harmonic Interference : This is similar to second channel interference, but the interfering station is on a frequency either higher or lower than that of the oscillator by one-half or one-third of the intermediate frequency for the second and third harmonics respectively. Higher harmonics are not usually important. The harmonics are usually generated in the frequency-changer ($f_x = f_s + f_i \pm f_i/n$).

Beat Interference, Fundamental : This occurs from a station spaced from the wanted signal by an amount equal to the intermediate frequency ($f_x = f_s \pm f_i$).

Beat Interference, Harmonic : This is similar to the foregoing but non-linearity in the frequency-changer is

WIRELESS SERVICING MANUAL

necessary for it to appear. It occurs from signals spaced by one-half or one-third of the intermediate frequency from the wanted station for the second and third harmonics respectively ($fx = fs \pm fi/n$).

Oscillator Harmonics: This form of interference is caused by harmonics of the receiver oscillator, usually the second or third, beating with signals to produce the intermediate frequency. This type of interference is usually confined to the long waveband ($fx = \frac{fs + fi}{n} \pm fi$).

In the foregoing, fx = frequency of station causing the interference; fs = frequency of station upon which the interference is found; fi = intermediate frequency; and n = order of harmonic involved.

I.F. Harmonic Feed-back: This type of interference occurs when harmonics of the intermediate frequency generated in the I.F. amplifier or detector are fed back to the pre-frequency-changer circuits.

With the degree of pre-selection included in most sets, all forms of interference, other than I.F. Harmonic Feed-back, rarely cause trouble except on the short waves or when local stations are involved. Practically speaking, it is impossible to obtain a frequency-changer which is completely free from harmonic generation, so that the only remedy for whistles of all types, except those due to I.F. Harmonic Feed-back, is an increase in pre-selection. When the ganging is inaccurate, the normal degree of pre-selection is greatly lowered, so that in any case where whistles are found the first thing to do is always to make sure that the ganging is as perfect as possible.

As a guide to the performance obtainable, it may be said that in a district 30 miles or so from a local station two signal-frequency circuits for a 110 kc/s intermediate frequency, or one for a 465 kc/s frequency, are adequate. There will be few, if any, whistles, but there is little factor of safety. At 10 miles from a pair of locals there will be quite a number of whistles, and to obtain the same performance three signal-frequency circuits are necessary for the lower intermediate frequency and two for the higher.

On short waves, second channel interference is almost inevitable with only one signal-frequency circuit, even with an intermediate frequency of 465 kc/s. Two are sufficient to give reasonable protection against it for frequencies up to some 10-15 Mc/s; above this three should be regarded as essential for first class results.

SUPERHETERODYNE WHISTLES

In ninety-nine cases out of a hundred, whistles on the medium waveband will be caused by the local station because it is so much stronger than other stations. As an example of the kind of thing to be expected, the signal frequencies at which whistles may occur due to high-power stations on certain frequencies are listed in Tables I, II and III for the chief forms of interference and for intermediate frequencies of 110 kc/s and 465 kc/s. The frequencies of the stations correspond to the present British station allocations. The superiority of the higher intermediate frequency in respect of the number of possible forms of interference is very evident.

An Absorption Wavemeter

The most useful tool in tracing the cause of whistles is a simple absorption wavemeter covering a band of 100 kc/s to 1,700 kc/s continuously. It should be connected in series with the aerial lead to the set, the receiver tuned so that the whistle which it is desired to eliminate appears, and the wavemeter tuned carefully through its range. One point will always be found at which both the signal and whistle disappear or are greatly weakened.

This occurs when the wavemeter is tuned to the wanted signal and is of no use for present purposes. The aim is to find a setting for the wavemeter control for which only the whistle disappears leaving the wanted signal unaffected. The wavemeter is then tuned to the station responsible for the whistle, and knowing its frequency and the frequency of the wanted signal, the type of interference can be found. In some cases, however, the type of interference is not very important for the remedy is the same for nearly all types—an increase in pre-selection.

Now it is not usually easy to increase the selectivity of the signal-frequency circuits adequately, assuming that the ganging has been

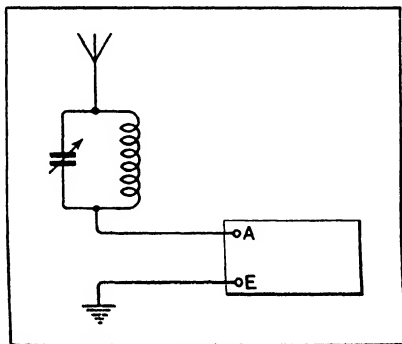

Fig. 71: A simple wavetrapp is often useful in removing whistles produced by a strong local signal

TABLE I
Frequencies upon which Interference may be found from

IF = 110 kc/s		North Region 668 kc/s	Scottish Region 767 kc/s	Welsh Region 804 kc/s	London Region 877 kc/s	West Region 977 kc/s	Midland Region 1013 kc/s	North Ireland Region 1050 kc/s	B.B.C. Light Programme 1149 kc/s
Second Channel ...		—	547 ± 9	584 ± 9	657 ± 9	757 ± 9	703 ± 9	830 ± 9	929 ± 9
I.F. Beat—									
Fundamental ..		558 ± 9	657 ± 9	694 ± 9	767 ± 9	867 ± 9	903 ± 9	940 ± 9	1039 ± 9
2nd Harmonic...		778 ± 9	877 ± 9	914 ± 9	987 ± 9	1087 ± 9	1123 ± 9	1160 ± 9	1259 ± 9
3rd Harmonic ..		613 ± 4.5	712 ± 4.5	749 ± 4.5	822 ± 4.5	922 ± 4.5	958 ± 4.5	995 ± 4.5	1094 ± 4.5
4th Harmonic ..		723 ± 4.5	822 ± 4.5	859 ± 4.5	932 ± 4.5	1032 ± 4.5	1068 ± 4.5	1105 ± 4.5	1204 ± 4.5
5th Harmonic ..		631.3 ± 3	730.3 ± 3	767.3 ± 3	840.3 ± 3	940.3 ± 3	976.3 ± 3	1013.3 ± 3	1112.3 ± 3
6th Harmonic ..		704.6 ± 3	803.6 ± 3	840.6 ± 3	913.6 ± 3	1013.3 ± 3	1049.6 ± 3	1086.6 ± 3	1185.6 ± 3
Harmonic Image—									
1st Harmonic ..		—	602 ± 4.5	639 ± 4.5	712 ± 4.5	812 ± 4.5	848 ± 4.5	885 ± 4.5	984 ± 4.5
2nd Harmonic ..		613 ± 4.5	712 ± 4.5	749 ± 4.5	822 ± 4.5	922 ± 4.5	958 ± 4.5	995 ± 4.5	1094 ± 4.5
3rd Harmonic ..		—	620.3 ± 3	657.3 ± 3	730.3 ± 3	830 ± 3	866.3 ± 3	903.3 ± 3	1002.3 ± 3
4th Harmonic ..		594.6 ± 3	693.6 ± 3	730.6 ± 3	803.6 ± 3	903.6 ± 3	939.6 ± 3	976.6 ± 3	1075.6 ± 3
Osc. Harmonic—									
1st Harmonic ..		169 ± 4.5	218.5 ± 4.5	237 ± 4.5	273.5 ± 4.5	—	—	—	—
2nd Harmonic ..		279 ± 4.5	—	—	—	323.5 ± 4.5	—	—	—
3rd Harmonic ..		—	—	—	—	252.3 ± 3	191 ± 3	203.3 ± 3	236.3 ± 3
4th Harmonic ..		—	182.3 ± 3	194.6 ± 3	218.9 ± 3	179 ± 3	284.3 ± 3	276.6 ± 3	—

TABLE II

Frequencies upon which Interference may be found from

IF = 465 kc/s

Type of Interference	North Region 668 kc/s	Scottish Region 767 kc/s	Welsh Region 804 kc/s	London Region 877 kc/s	West Region 977 kc/s	Midland Region 1013 kc/s	North Ireland Region 1050 kc/s	B.B.C. Light Programme 1149 kc/s
Second Channel ..	—	—	—	—	—	—	—	219 ± 9
I.F. Beat—	—	302 ± 9	339 ± 9	—	512 ± 9	548 ± 9	585 ± 9	684 ± 9
Fundamental ..	1133 ± 9	1232 ± 9	1269 ± 9	1342 ± 9	1442 ± 9	1478 ± 9	—	—
2nd Harmonic ..	900.5 ± 4.5	999.5 ± 4.5	571.5 ± 4.5	644.5 ± 4.5	744.5 ± 4.5	780.5 ± 4.5	817.5 ± 4.5	916.5 ± 4.5
3rd Harmonic ..	823 ± 3	612 ± 3	649 ± 3	722 ± 3	822 ± 3	858 ± 3	895 ± 3	994 ± 3
Harmonic Image—	—	922 ± 3	959 ± 3	1032 ± 3	1132 ± 3	1168 ± 3	1205 ± 3	1304 ± 3
2nd Harmonic ..	—	—	—	179.5 ± 4.5	279.5 ± 4.5	—	—	—
3rd Harmonic ..	—	—	561.5 ± 4.5	644.5 ± 4.5	744.5 ± 4.5	780.5 ± 4.5	817.5 ± 4.5	916.5 ± 4.5
Osc. Harmonic—	—	—	184 ± 3	257 ± 3	357 ± 3	—	—	—
2nd Harmonic ..	—	—	—	567 ± 3	667 ± 3	703 ± 3	740 ± 3	839 ± 3
3rd Harmonic ..	—	150 ± 4.5	169.5 ± 4.5	206 ± 4.5	256 ± 4.5	274 ± 4.5	292.5 ± 4.5	—
—	—	—	—	—	—	—	—	—
—	—	—	—	—	—	—	—	—

WIRELESS SERVICING MANUAL

accurately carried out. As the whistles are usually due to one or two powerful local stations only, the best remedy is to include a wavetrap in the aerial circuit and to tune it to the local station. This reduces the input, as far as the receiver is concerned, to something little more than the level of a strong Continental signal and in most cases wipes out nearly all the whistles. The connections for such a wavetrap are shown in Fig. 71, and they can easily be made externally to the receiver.

A further advantage of the trap is that by reducing the aerial input from the local station it greatly lessens the possibility of distortion when receiving this station. Very strong stations are sometimes distorted through an I.F. valve becoming overloaded, for there are limits to the range of control given by even the best A.V.C. system.

Using Two Traps

In districts where there are two local stations, it will often be found that the inclusion of a wavetrap removes about half the whistles only. This is because half of them are due to one local station and the other half to the other, and the remedy is to fit two wavetraps, one being tuned to each of the offending stations.

Trouble may also be experienced from a station working on the intermediate frequency. With a low intermediate frequency, a high power C.W. morse transmitter will usually be the offender, and since high-speed sending is often employed the audible effect is similar to a steady whistle when a station is tuned in. Although the interference is usually evident throughout the tuning range of the set, it is at its worst towards the upper end of the long waveband.

With an intermediate frequency of the order of 465 kc/s, the interference is generally from spark transmitters and is at its worst at the upper end of the medium waveband and at the lower end of the long. Here again the remedy is to use a wavetrap in the aerial circuit tuned to the intermediate frequency.

When a "large-primary" aerial coil is used an I.F. wavetrap is almost essential, because the aerial circuit then resonates close to the intermediate frequency. As the primary is of high impedance, an acceptor type of wavetrap is more effective than a rejector. This consists merely of a coil and condenser in series connected between the aerial and earth terminals as in Fig. 66 (b). The rejector wavetrap of Fig. 66 (a) or Fig. 71 is more effective with a "small-primary" aerial coil.

SUPERHETERODYNE WHISTLES

Any number of wavetraps may be used and connected in series with one another as shown in Fig. 72. Here three are used, one for each of two local stations and a third tuned to the intermediate frequency. The precise values of the components employed naturally depend upon the particular frequencies to which the traps must be tuned. The values are readily worked out from the formulæ given in any reference book or from Abacs.

The amount of rejection depends upon the efficiency of the coils and condensers, but it is usually possible to obtain good results with small coils and compression type condensers. Acceptor traps must, of course be connected in parallel with one another, not in series as with rejector traps.

Whistles which are due to the feed-back of harmonics of the intermediate frequency will not respond to wavetraps, for they are due to stray coupling in the receiver itself. Feedback from any I.F. circuit which generates harmonics to any pre-frequency-changer circuit can cause this trouble, but the detector is the usual source of the trouble for the signals are strongest at this point and it necessarily generates harmonics. The I.F. amplifier should cause no trouble, for it ought to be linear; if it is not linear, however, it will produce harmonics and may cause trouble. The last I.F. valve is usually the danger point. It may be remarked that this type of interference is more likely to occur with modern receivers than with older sets, for it is now the custom to operate the detector at a large input and this not only makes harmonic production more likely, but results in a bigger voltage being fed back to the input through a given amount of coupling.

At first sight it would appear that this trouble is easily diagnosed, for one would expect whistles to occur only at

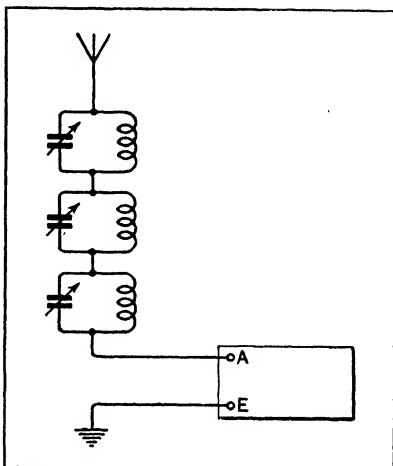

Fig. 72: Three rejector wavetraps can be used as shown here. Two are tuned to local stations and the third to the intermediate frequency

WIRELESS SERVICING MANUAL

certain definite signal frequencies which are multiples of the intermediate frequency. This is not so, however, and with a low intermediate frequency it is possible for there to be a whistle on practically every medium wave station !

A Band of Frequencies

This effect is brought about by the fact that the I.F. amplifier passes a band of frequencies and this band width is effectively multiplied by the degree of harmonic involved. Suppose, for instance, that the intermediate frequency is 110 kc/s, and that high harmonics are troublesome. In a high-quality receiver, frequencies up to 9 kc/s may be passed, so that the I.F. amplifier will respond to frequencies between 101 kc/s and 119 kc/s.

If it is desired to receive a station on 970 kc/s one would not at first expect there to be any trouble, for the nearest harmonic frequency is 990 kc/s, which is 20 kc/s away from the wanted signal. If the tuning is altered slightly, however, so that the set is tuned to 968 kc/s, the station still remaining on 970 kc/s, the intermediate frequency produced by the oscillator beating with the signal will be 108 kc/s ; the ninth harmonic of this is 972 kc/s, and this will beat with the signal to produce a 2,000 c/s note. Thus although there may be no whistle when the set is tuned exactly to the station, it will appear with quite a small degree of mistuning.

Table IV shows the range of frequencies over which this type of interference may be found with an intermediate frequency of 110 kc/s. On the long waveband, the band of 202-238 kc/s may contain whistles and, with the exception of the band of 595-606 kc/s, the whole of the medium waveband. In some cases, the possible interference bands for each harmonic overlap. Thus, the 9th harmonic may cause trouble between 909 kc/s and 1,071 kc/s, the 10th from 1,010 kc/s to 1,190 kc/s, and the 11th from 1,111 kc/s to 1,309 kc/s.

It can be seen that in the band 1,010-1,071 kc/s both 9th and 10th harmonics can cause whistles, while in the range 1,111-1,190 kc/s the 10th and 11th harmonics may give trouble. Table V shows the results with a higher intermediate frequency of 465 kc/s and it can be seen that only the 2nd and 3rd harmonics can possibly give this type of interference and the ranges over which whistles may be experienced are confined to 912-948 kc/s and 1,368-1,422 kc/s.

In practice, the high harmonics do not usually cause serious trouble, for they are much weaker than the 2nd and 3rd harmonics, and if the stray couplings are kept small enough for

TABLE III
Frequencies upon which interference may be found from Droitwich 200 kc/s

Intermediate Frequency (kc/s)	Fundamental I.F. Beat (kc/s)	2nd Harmonic I. F. Beat (kc/s)	3rd Harmonic I. F. Beat (kc/s)
110	310 ± 9	255 ± 4.5	163.3 ± 3 and 230.6 ± 3
465	665 ± 9	—	—

TABLE IV
I.F. Harmonic Interference

Degree of Harmonic Interference	Frequencies	3	4	5	6	7
Degree of Harmonic Interference	220 ± 18	—	—	550 ± 45	660 ± 54	770 ± 63
Degree of Harmonic Interference	880 ± 72	900 ± 81	1100 ± 90	1210 ± 99	1320 ± 108	1430 ± 117

TABLE V
I.F. Harmonic Interference

Degree of Harmonic Interference	Frequencies	3	4	5	6	7
Degree of Harmonic Interference	930 ± 18	1395 ± 27	—	—	—	—

WIRELESS SERVICING MANUAL

only a moderate degree of 2nd and 3rd harmonic interference, the higher harmonics are likely to be negligible. It is, however, very difficult completely to eliminate trouble from the 2nd and 3rd harmonics, for in sensitive receivers the merest trace of coupling between the circuits concerned will lead to prominent whistles at the appropriate signal frequencies. In bad cases, actual instability may be set up when the set is tuned to twice the intermediate frequency.

The remedies are really the same as those necessary in a straight set suffering from instability, but when testing, it is, of course, necessary to provide a signal at the appropriate frequency in order to obtain the whistle. Although a receiver may be unstable with or without a signal, the worst effects of harmonic feed-back are only apparent when a signal is present.

In order completely to eliminate the trouble, very thorough screening of the detector is essential and in some cases of the I.F. amplifier also. Such screening will be nullified if currents of the harmonic frequencies are allowed to flow in the connecting leads to other circuits. The H.T. supply to the last I.F. valve must be well decoupled, and sometimes the screen supply also, while the A.V.C. line must have an initial stage of filtering placed as closely as possible to the A.V.C. diode and contained within any detector screening.

The filtering in the A.F. output circuit of the diode detector must be good, otherwise the harmonic frequency potentials may be amplified in the A.F. stages and radiated from them. In some cases, it is necessary to use a tuned filter circuit, as shown in Fig. 73, tuned to the 2nd harmonic of the intermediate frequency. The coil *L* employed in this circuit should be of suitable inductance to tune to the required frequency with a capacity *C* of about 30-50 $\mu\mu\text{F}$.

This form of interference, although objectionable, can occasionally be turned to good account. When a calibrated test oscillator is not available the chief difficulty in trimming an I.F. amplifier is that one has no knowledge of the frequency to which it is adjusted. It is possible to deduce the frequency, however, by noting on which stations the whistles caused by harmonic feed-back occur. By introducing deliberate coupling between the detector and aerial circuits, as by running the aerial lead amid the detector wiring, a strong whistle should be obtained from the 2nd harmonic.

The accuracy is only reasonably high if several whistles can be found. The set should be tuned accurately to each station and the pitch of the whistle noted. The station on which the

SUPERHETERODYNE WHISTLES

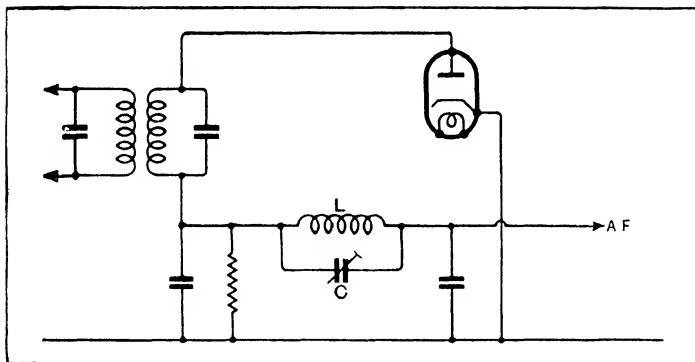

Fig. 73 : In order to eliminate I.F. harmonic feed-back a circuit tuned to twice the intermediate frequency is sometimes needed in the detector

whistle has its lowest pitch should be selected and the intermediate frequency is then nearly equal to one-half the frequency of the station. If the whistle has a pitch of about 1,000 c/s, the error in estimating the intermediate frequency is only about 1 kc/s.

CHAPTER 15

FREQUENCY-CHANGERS

NEARLY all modern superheterodynes have a frequency-changer (or mixer) of the multiplicative type, and the once popular additive type is rarely found in ordinary apparatus. The multiplicative mixers are those in which the signal and oscillator voltages are applied to different electrodes and the alternating anode current depends on the product of the two control-electrode voltages. In an additive mixer, however, the signal and oscillator voltages are usually applied to the same control electrode, and the anode current is then a function of the sum of the voltages.

Typical examples of multiplicative mixers are heptodes and hexodes—whether or not combined with triode oscillator sections—but tetrodes or pentodes with anode or suppressor injection of the oscillator voltage are also of this type. The additive mixers are diodes, triodes or any other valve in which the signal and oscillator voltages are applied to the same control electrode.

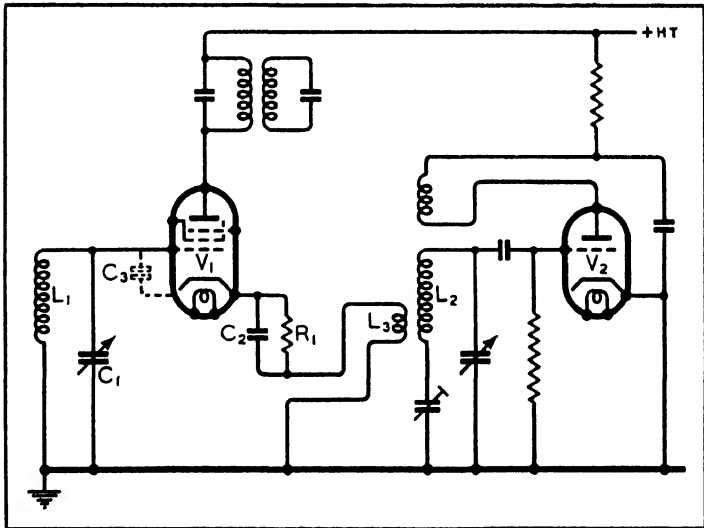

Fig. 74 : This diagram shows a typical two-valve frequency-changer of a type once very common. It is now rarely used

FREQUENCY-CHANGERS

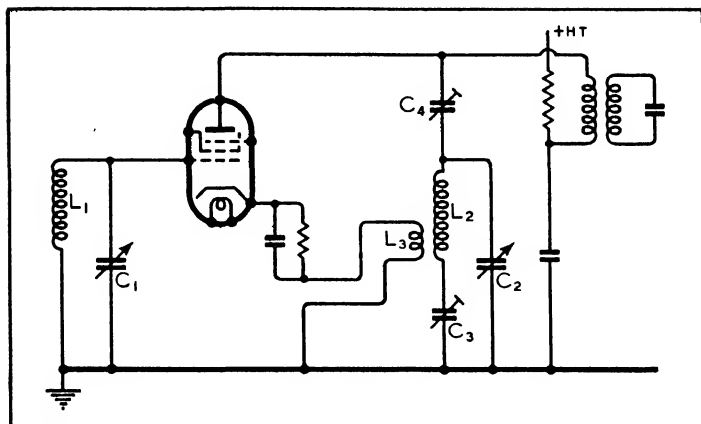

Fig. 75 : Single valve frequency-changers using a tetrode or pentode valve were at one time often used in the cheaper sets

The great practical difficulty with additive mixers lies in the coupling between the signal and oscillator tuned circuits. This makes the oscillator frequency dependent on the signal-frequency tuning, and as a result, ganging becomes quite difficult. The most successful circuit of this type is the cathode-coupled frequency-changer of Fig. 74. A triode oscillator V_2 of conventional design is used and the mixing valve is a tetrode or pentode V_1 adjusted to work as an anode bend detector, cathode-bias being obtained by R_1 . The signal input circuit is L_1C_1 , and the oscillator voltage is injected into the cathode circuit by means of the coupling coil L_3 .

The voltages across L_1C_1 and L_3 clearly add between grid and cathode, and there is at first sight no coupling between the tuned circuits themselves. In actual fact, however, there is coupling through the grid-cathode capacity C_3 of V_1 . Even with an intermediate frequency as low as 110 kc/s, the circuit is quite satisfactory on the medium waveband, and the pulling between the circuits is small enough to be unimportant.

Pulling is very serious on short waves, however, and the circuit there becomes almost impracticable. For the best results V_1 should not be of the variable-mu type and it should not be connected to the A.V.C. system.

A similar circuit to this, but one in which a single valve acts as a detector-oscillator, is shown in Fig. 75. The signal

WIRELESS SERVICING MANUAL

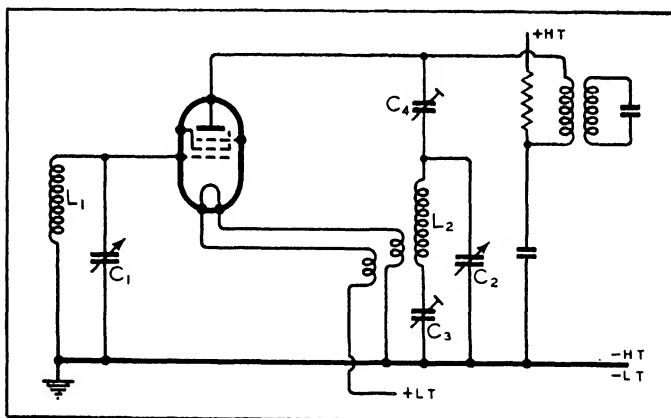

Fig. 76 : In a battery set, the circuit of Fig. 75 is modified to the form shown here. The filament coils are tightly coupled to L2

circuit is L_1C_1 and the oscillator $L_2C_2C_3$. The latter is fed through C_4 from the valve anode and coupled to the cathode coil L_3 which forms the reaction coil. The I.F. transformer primary is tuned by C_4 , and the oscillator tuned circuit actually forms a part of the primary circuit. At the oscillator frequency, the transformer primary functions as an R.F. choke, while the I.F. trimmer C_4 becomes the feed condenser for the oscillator circuit.

The circuit is not suitable for short waves, but can be made to give good results on the medium and long wavebands. C_4 is adjusted in the usual way at the intermediate frequency, for it is the first I.F. trimmer. The signal and oscillator circuit trimmers are also adjusted quite normally.

The performance is more dependent upon the kind of valve used than most circuits, and this is likely to be the greatest practical difficulty with it to-day. It is only found in sets of about 1932-1934 manufacture and the valves used are probably obsolete now. A replacement of different characteristics will probably demand some juggling with screen and bias voltages, and even then, the results may not be as good as they were originally because the grid-cathode capacity will probably be different.

This type of mixer was also used sometimes in battery sets and then the circuit usually took the form of Fig. 76. Here

FREQUENCY-CHANGERS

two coupling coils are used—one in each filament lead—because there is no separate cathode to the valve. It is important that these coils be of low D.C. resistance, otherwise the voltage drop across them will result in the valve being underrun. In other respects the circuit functions like the mains variety of Fig. 75.

The multiplicative mixers fall into two main categories—heptodes and octodes, with the oscillator voltage applied to an inner grid and the signal to an outer grid, and pentodes, hexodes, and heptodes in which the signal is applied to an inner grid and the oscillator to an outer. These valves usually have a built-in triode oscillator section, but some have not and require a separate oscillator; even those having a built-in oscillator are sometimes used with a separate one.

The essential difference between the heptode and the octode of the first category is that the latter has one more grid. It is connected internally to the cathode and can be ignored by the user. It is a suppressor grid and tends to increase the A.C. resistance of the valve. The essential difference between the heptode and the octode is thus the same as that between the screened tetrode and the pentode.

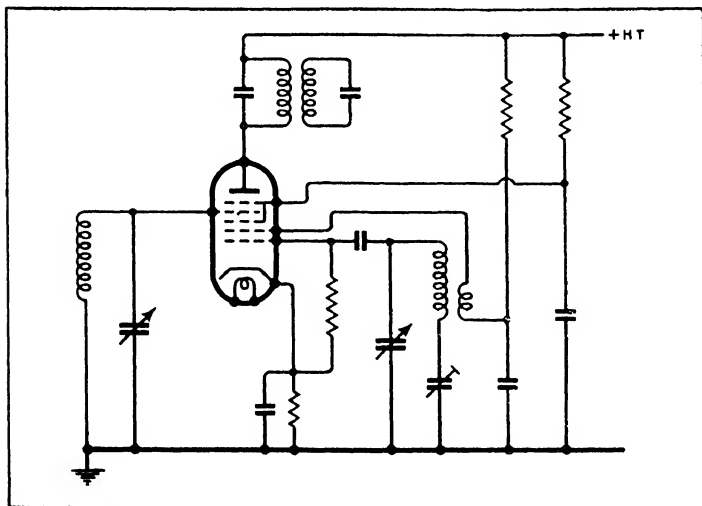

Fig. 77 : This diagram shows the usual connections for a heptode frequency-changer

WIRELESS SERVICING MANUAL

The basic circuit for both valves is shown in Fig. 77. Numbering the grids in order from the cathode, G_1 and G_2 form the oscillator electrodes and with the cathode give a triode oscillator. G_2 usually consists of a number of bars mounted away from the main electron stream, but G_1 is a proper grid in the main stream. This electron stream is modulated by the oscillator and passes through the inner screen grid G_3 on the outside of which it forms a virtual cathode. The density of this virtual cathode varies at oscillator frequency since it is dependent on the instantaneous potential of G_1 . Electrons from it are attracted by the positive outer screen grid G_5 and in their passage to it are controlled by the signal grid G_4 , which usually has variable- μ characteristics. Outside G_5 the electrons pass to the anode to form the anode current, the value of which depends on the instantaneous potential of both G_1 and G_4 .

There is little special about fault-finding with this type of mixer. The electrode potentials should be checked in the usual way and the oscillator amplitude can be measured by noting the grid current through R_1 —again as in any other grid leak oscillator.

Coupling between the signal and oscillator circuits is by no means absent, for there are not only small inter-electrode capacities but there is a negative mutual conductance effect between G_1 and G_4 . The valve is a great improvement on the cathode-coupled pentode of Fig. 74 and can be used effectively on short-waves. Above about 15 Mc/s, however, the coupling between the circuits is really excessive and although the circuit can be made to work quite well it becomes a little tricky. Some octodes include a built-in neutralizing condenser to reduce coupling effects, and these are a considerable improvement.

The second category of multiplicative mixers is illustrated by the triode-hexode of Fig. 78. This is a mixing hexode and a separate triode built into one envelope and having the cathodes internally connected. The triode grid is also usually joined internally to the injector grid G_3 of the hexode. A triode-heptode is essentially the same, but has a suppressor grid between the outer screen grid G_4 and the anode. It consequently has a higher A.C. resistance.

In general, the valve is much more suited to short wave reception than the heptode or octode. Because of the separate cathode for the oscillator section, the triode part is of higher mutual conductance and so oscillates more readily. This

FREQUENCY-CHANGERS

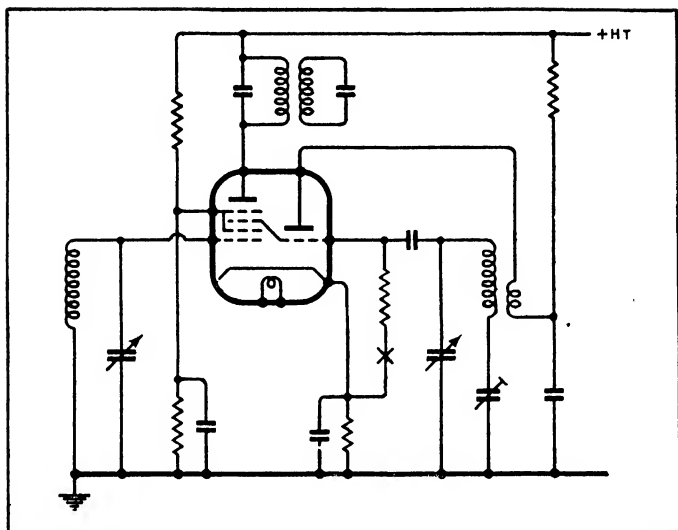

Fig. 78 : The triode-hexode is now one of the most widely used frequency-changers, and the circuit is of this general form, but sometimes differs in minor details

means that the valve will function efficiently at higher frequencies and also that at frequencies where both are efficient better frequency stability can be obtained. In addition, the triode-hexode is superior because the coupling between the signal and oscillator parts of the valve is lower. In practice, this lower coupling is achieved only if the amplitude of oscillation in the triode section is kept below a certain maximum.

These mixers like the triode-hexode, with G_1 for the signal grid, have two disadvantages compared with the heptode type in which G_1 is the oscillator grid. Electron transit times are greater and at really high frequencies—above about 25 Mc/s—they have a lower input impedance at the signal grid. They also take a larger cathode current. This last is unimportant in a mains set, but is the reason why they are not common in battery sets.

Instead of a double valve, two separate valves can be used and at one time an R.F. pentode mixer with separate triode oscillator was sometimes employed. The suppressor grid was used for oscillator injection, being frequently connected directly

WIRELESS SERVICING MANUAL

to the triode grid. The objections to this arrangement are that a very large oscillator amplitude is needed because the suppressor grid is usually of too open mesh to give good control over the electron stream, and the mixer has a low output resistance and so damps the I.F. transformer heavily.

Nowadays, even when two valves are used, the mixing valve is nearly always a hexode or heptode, the most frequent course being to use a triode-hexode or triode-heptode and ignore the triode section. The advantage of using a separate valve for the oscillator is that it is often possible to obtain better frequency stability.

For a frequency-changer to be satisfactory it is necessary not only that it be efficient and as free as possible from harmonic generation, but that the oscillator stability be high. This last means that the oscillator frequency should be dependent on the setting of the tuning control only. In practice, this is never achieved. It is always affected in some degree by its own electrode potentials, by the electrode potentials of the mixer, and by temperature. These are dealt with in detail later, but it is often easier to reduce them when the mixer and oscillator valves are entirely separate than when they are combined in one envelope.

Whatever the form of the mixer, the oscillator itself follows more or less standard lines and typical circuits are shown in Fig. 79. Oscillator grid bias is nearly always obtained by using a grid leak and condenser, as in (a) and (c), but occasionally cathode-bias (b) is adopted.

When oscillator and mixer are a multiple valve, the tuned-grid oscillator (c) is nearly always used, but when it is entirely separate the tuned anode circuit is sometimes adopted. More often, the cathode-tap Hartley circuit is used and sometimes the modified Colpitt's as shown in Fig. 80 (a) and (b) respectively. The latter oscillates by virtue of the grid-cathode capacity of the valve and the cathode-earth capacity, which includes the self-capacity of the choke Ch. This circuit is suitable only for short-waves.

Whatever kind of oscillator is used it differs from an amplifier in one important point way—the anode current has a value when the valve is oscillating which is different from that when it is not oscillating. This enables a ready test for an oscillator to be devised and it is important because the failure of the oscillator will render any superheterodyne inoperative.

The test is to connect a milliammeter in series with the anode feed resistance R_1 (Figs. 79 and 80), on the H.T. side of it,

FREQUENCY-CHANGERS

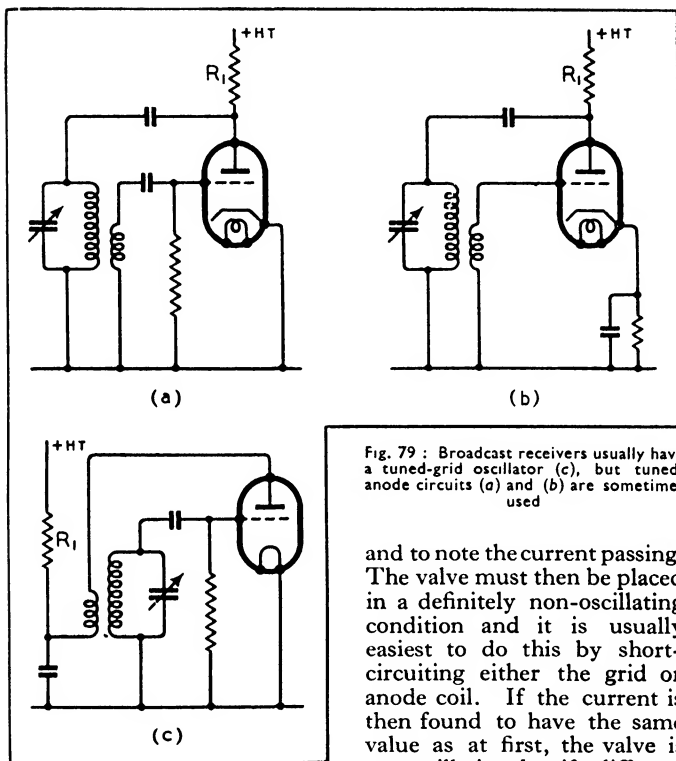

Fig. 79 : Broadcast receivers usually have a tuned-grid oscillator (c), but tuned-anode circuits (a) and (b) are sometimes used

and to note the current passing. The valve must then be placed in a definitely non-oscillating condition and it is usually easiest to do this by short-circuiting either the grid or anode coil. If the current is then found to have the same value as at first, the valve is not oscillating, but if a different

value of current is found, then it is quite certain that the valve oscillates. The direction of the change of current depends upon the method of biasing.

With grid leak oscillators ((a) and (c), Fig. 79) the current is lower when the valve is oscillating than when it is not; consequently, if all be in order, short-circuiting one of the coils should cause a rise in anode current. In a typical case, the anode current of an oscillating valve might be 3 mA, whereas with the same applied voltages it might be 5 mA when the valve is not oscillating.

In cases where battery or cathode biasing is used, however, the current is higher in the oscillating than in the non-oscillating

WIRELESS SERVICING MANUAL

condition and the change of current is much larger. A feed resistance R_1 is often essential to limit the current, for if the possible current consumption is not restricted in some such way, it can be very heavy indeed ; a small battery valve can easily take 20 mA or more.

When checking for oscillation, care should be taken to check at several different points throughout the tuning range, for it often happens that oscillation is obtained over a portion of the range only. In general, when the valve is oscillating the anode current varies somewhat over the tuning range and with a grid leak oscillator it usually increases at the low frequency end of the tuning range.

Causes of Non-Oscillation

Non-oscillation may be due to many defects which are in essence no different from those which may occur in any stage. Incorrect voltages, a defective valve, a faulty condenser, short-circuited turns on a coil, can all cause this fault to develop and can be found by the application of the usual tests. With a newly-constructed receiver, however, or when alterations to this portion of a set have been made, the connections to the coils should always be checked. The correct connections are always the same and are easily memorised if the tuned and reaction coils be regarded as a continuous winding which is merely split at one point for the H.T. and valve cathode connections ; the two outer ends are then the grid and anode connections. In other words, if both coils are wound end to end and in the same direction, the outer ends must be taken to grid and anode. The same connections hold if one coil be wound over the other, as can readily be seen if one imagines the coils to be pulled apart so that they are end to end. With multilayer coils wound in the same direction, if the outer end of one coil is taken to anode, the inner end of the other must be joined to grid.

Although it is necessary that the oscillator shall function smoothly over the waveband, this alone is not sufficient to ensure satisfactory operation of the frequency-changer. It is necessary also that the right amplitude of oscillation be applied to the mixer. When the oscillator valve is quite separate this may be achieved in the coupling between the two, but with a combined valve it must be arranged by adjusting the output of the oscillator itself. With the usual triode-hexode the amplitude can easily be checked by inserting a microammeter in series with the grid leak at " X " of Fig. 78.

When the valve is not oscillating the grid current will be of

FREQUENCY-CHANGERS

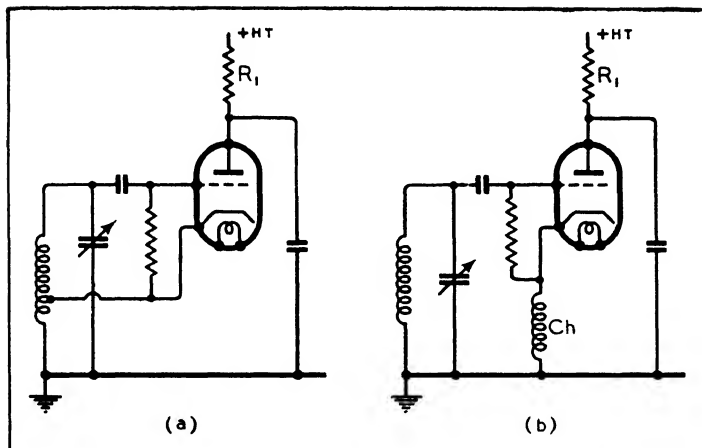

Fig. 80: The Hartley (a) and Colpitt's (b) oscillators are quite frequently used in short-wave equipment

the order of $10 \mu\text{A}$. and it will be much higher when it is oscillating. The change of current in microamperes multiplied by the value of the grid leak in megohms gives a figure which is about 83 per cent. of the oscillator R.F. voltage. Thus, if the change of current is $200 \mu\text{A}$. and the grid leak is 0.05 megohm, the oscillator amplitude is about 12 volts.

The efficiency of the frequency-changer is a function of the oscillator amplitude. As the latter is increased from zero, the efficiency rises rapidly, reaches a maximum, and then falls slowly. The maximum is usually at about 10 volts oscillator amplitude, but it is high over the range of about 8 volts to 20 volts.

It will often be found that the oscillator amplitude varies considerably as the set is tuned over a waveband. It often varies in the ratio of 2 or 3 to 1, and it usually falls towards the low-frequency end of the band. As the maximum of the oscillator amplitude-efficiency curve is a very flat one, it might be thought desirable to adjust matters so that the lowest amplitude is about 8 volts and to let the variations be all above this on the flat part of the curve.

While it is sometimes permissible to do this on the medium and long wavebands, it should never be done on short waves.

WIRELESS SERVICING MANUAL

In the author's experience the optimum oscillator amplitude is a maximum which should never be exceeded on short waves. Excessive oscillator voltage gives rise to coupling between the signal and oscillator circuits and if the difference between their resonance frequencies is only a small fraction of the oscillator frequency, as it is on the short waves, the signal circuit can be shock-excited by the oscillator under certain tuning conditions. The effect is a number of very strong spurious signals.

It is brought about by an excessive instantaneous negative potential on the injector grid of the mixer. The normal operation of the hexode is that the electron stream from the cathode is attracted by the positive screen G_2 and modulated en route by the signal grid G_1 . Some of the electrons land on G_2 , but the majority pass through it to form a virtual cathode outside G_2 , the density of this virtual cathode varying in accordance with the signal applied to G_1 . The outer screen G_4 attracts electrons from this virtual cathode and they are modulated in their passage to it by the oscillator voltage on the injector grid G_3 . Some land on G_4 , but most pass through it and reach the anode.

Maximum efficiency is obtained when the oscillator amplitude is such that G_3 is so negative during most of the oscillator cycle that the current to G_4 and the anode is completely cut-off. The current then passes in short spurts when the oscillator voltage swings positively. The oscillator, in fact, acts as an interrupter.

Now the position of the virtual cathode outside G_2 depends on the potential of G_3 as well as on that of G_2 and G_4 . When the potential of G_3 is very negative the virtual cathode is pushed close to G_2 . Electrons which come through G_2 with a velocity above the average are turned back and may be so repelled by the negative grid that they pass through G_2 a second time and find themselves travelling towards G_1 on the inside of G_2 . They soon turn back towards G_2 and either land on it or pass through it once again to its outside. While inside G_2 , however, they induce a charge on G_1 and a minute grid current flows.

The resulting current is of a random nature, but as it can only occur when the injector grid potential is more negative than a certain value, it is definitely related to the oscillator frequency. The nearest simple description is perhaps to call it a random current interrupted at oscillator frequency.

Even if the oscillator amplitude is such that electrons do not actually return through G_2 , the change in position of the virtual cathode outside G_2 is sufficient to influence G_1 to some extent, because the screening effect of G_2 is not perfect.

FREQUENCY-CHANGERS

The net result of all this is to give some coupling between the signal and oscillator circuits and to set up some oscillator voltage on G_1 . The oscillator voltage on G_1 increases as the ratio of the signal and oscillator frequencies gets nearer to unity—that is, as the frequency increases—and the first result is to produce grid current at low signal grid biases. It is, therefore, common practice to use more grid bias on G_1 on short waves than would be necessary on the medium waveband. The second result is to produce spurious signals which are often suggestive of instability of the R.F. amplifier.

To avoid these effects it is most important to limit the amplitude of oscillation to a maximum which is usually about 10 volts, and to let any variations in the amplitude occur below this figure. Variations of the order of 3-1 can no longer be tolerated, however, for the efficiency would suffer severely.

Constant Oscillator Output

It is necessary, therefore, to obtain a more even output from the oscillator and there are several expedients which can be adopted. In general, the oscillator output is at a maximum at or near the high-frequency end of the tuning range because, with variable condenser tuning, the dynamic resistance of the tuned circuit increases with frequency. One simple way of reducing the variations of output is to shunt the tuned circuit with a resistance. If this is equal to the dynamic resistance at the low-frequency end of the band, the variation of total dynamic resistance over the band must be less than 2 : 1. The output at all points is reduced, but can be brought back to normal by increasing the reaction coupling and/or the H.T. voltage.

While sometimes useful, this scheme is not a good one because the tuned circuit is more heavily damped and the frequency stability is consequently reduced. Better alternatives are to connect resistances in series with the grid or anode leads of the valve. In conjunction with the valve capacities they form attenuators giving more attenuation at high frequencies than at low, and so even up the output. The values depend on all the other circuit constants and must be found by trial, but 50 ohms to 1,000 ohms is usual. Unfortunately, even these resistances reduce frequency stability, for not only do they damp the tuned circuit, especially at the high-frequency end of the band, but they cause a phase change in the oscillator circuit.

Apart from parasitic oscillation and spurious signals, which must at all costs be avoided, the most important thing in a

WIRELESS SERVICING MANUAL

frequency-changer is the frequency stability of the oscillator. If the set is not to require continual re-tuning, it is essential that any incidental changes of oscillator frequency be small compared with the band-width of the I.F. amplifier. Thus suppose that the band-width is 10 kc/s. When a signal is tuned in it will be centred on the pass-band and both sidebands up to 5 kc/s will be passed. Now if the oscillator drifts by 1 kc/s the carrier will be 1 kc/s off the centre of the pass-band and sidebands up to 4 kc/s on one side and 6 kc/s on the other will be passed. Double-sideband reception up to 4 kc/s only will then be possible, with an approach to single-sideband reception up to 6 kc/s. There will be some change of quality, but in this case not very much.

Suppose, however, that the drift reaches 5 kc/s. Double-sideband reception will be confined to the lower frequencies, and there will be single-sideband reception up to 10 kc/s. There will then be considerable amplitude distortion because the linear detector required for double-sideband reception is very far from right for single sideband. If the drift is any greater, the carrier will fall outside the pass-band and its amplitude will fall very rapidly; it may easily become weaker than the sidebands. In general, if distortion is to be small the frequency drift must not exceed some 10 per cent. of the band-width. On short waves, where the signal is probably already distorted by selective fading, probably 20 per cent. drift can be tolerated.

Drift is especially important in push-button sets, because unless A.F.C. is fitted, the user has no way of correcting for it. It must then be kept always below 10 per cent. of the band-width.

Oscillator drift arises from many different causes, but there are always small changes in the values of the circuit "constants." The oscillator inductance and capacity are both affected by temperature, while the mutual conductance and A.C. resistance of the valve are affected by the voltages applied to the electrodes. Any factor which alters the effective resistance or reactance of the oscillator tuned circuit affects the frequency.

The degree of stability required is very high indeed on short waves and is by no means easy to achieve. On the medium waveband, 1 kc/s drift corresponds to a stability varying from 1 part in 1,000 at the low frequency end to 1 part in 2,000 at the high frequency end. At 30 Mc/s (10 metres), however, it is 1 part in 30,000.

The frequency variations are of two kinds—slow and rapid.

FREQUENCY-CHANGERS

The slow changes are usually caused by temperature effects. When a set is first switched on the temperature of all its parts is at the ambient, i.e., the temperature of the room. Heat is generated in the cathode of the oscillator and as a result of expansion the inter-electrode capacities change. The major part of this change occurs before the valve is properly operative, and is unimportant, but small changes may still occur for some minutes afterwards. The effect on frequency depends largely upon the fraction of the total tuning capacity which the changes represent. To keep the effect small the tuning capacity should be as large as possible.

In addition to the oscillator, all the valves in the set produce heat, and the mains transformer, speaker field, and resistances contribute their quota. A typical mains set consumes 60 to 100 watts and all but the minute proportion radiated as sound by the loud speaker is dissipated as heat within the cabinet. It is, therefore, inevitable that the temperature inside the cabinet should rise above the ambient.

Ventilation

The extent of the rise depends chiefly upon the arrangements for ventilation and with good design it can be kept small. With good design, too, the set will attain its final temperature quickly. Unless temperature compensation is adopted, the oscillator frequency will drift while the temperature is changing. In some of the older sets it is not uncommon for the oscillator to drift 5 kc/s or so in the first 15 minutes after switching on, even on the medium waveband. In such sets it may take an hour or so for real stability to be reached.

The layout of the parts and the ventilation have an enormous effect upon the stability. This is easily seen by considering an extreme case. Suppose the set is completely sealed so that there is no ventilation at all, and suppose also that the case is perfectly lagged so that there is no loss of heat through its walls. Heat is continually being generated inside the case, and there is no loss of heat; therefore, the temperature rises continually. Frequency stability is then never achieved.

If the case is not perfectly lagged, the interior will eventually reach a temperature such that the loss of heat through its walls equals the rate of internal heat generation. A stable condition then exists and drift will cease. If ventilation is provided, however, heat will be lost more easily, and the stable condition will be reached at a lower temperature and more quickly. The

WIRELESS SERVICING MANUAL

drift will be reduced in magnitude and reach its maximum value more quickly.

The main principles in reducing thermal drift are to get the heat necessarily produced in the frequency-changer away from it as quickly as possible and to prevent heat generated in other parts of the set from reaching it. The first thing is to mount especially hot parts like output valves, rectifiers, speaker fields (and sometimes mains transformers !) and hot resistances as far as possible from the frequency-changer circuits. The second thing is to give these hot parts plenty of ventilation so that the heat is taken right outside the cabinet. This is best done by providing holes in the case immediately above and below the hot parts and *adequately large holes in the chassis*. For an output valve of 10-15 watts anode dissipation a hole $1\frac{1}{2}$ in. diameter immediately above it and another below it are adequate if the chassis has holes of the same total effective area around the valveholder. The holes in the case must usually be covered with gauze, so that the effective area is reduced, and becomes perhaps only 1 sq. in. Eight holes of 0.4 in. diameter spaced around the valveholder will provide an unimpeded path for the air flow.

Never forget the chassis holes. It is no use making a large outlet at the top of the set and a large inlet at the bottom, if the chassis between the two obstructs the free flow of air between them.

If the construction is such that it is not possible to space the hot parts widely from the frequency-changer, then having provided ventilation as described above, it will pay to erect a heat screen around the hot parts. This should take the form of a vertical metal screen fitting tightly between the chassis and the case. As the hot parts are usually above the chassis, it is generally sufficient for the heat screen to be above the chassis only, but if there is anything hot underneath, then a screen will be needed there too. The screen should be of bright metal, preferably polished, on the side facing the heat. It is sometimes advantageous to lag the other side with heat insulating material, but is often unnecessary.

The frequency-changer itself should be laid out so that its parts are in as cool a place as possible. It is usually best to mount the gang condenser above the chassis and alongside the valve, with the oscillator coil and all trimmers and switches under the chassis beneath the gang condenser. Any resistances generating an appreciable amount of heat, such as H.T. dropping resistances and screen-feed potentiometers, should be mounted

FREQUENCY-CHANGERS

above the chassis and well away from the gang condenser.

The valve will generally need a screen for electrical reasons and the opportunity should be taken of turning it into a chimney for ventilation. To this end it should be of such height that it almost touches the top of the cabinet, which should have a hole cut in it immediately above. The top of the valve screen must not be solid, as it usually is, but must be covered with gauze or have a large number of holes drilled in it. The chassis around the valvholder and inside the screen must be drilled with a large number of holes to allow the free entry of air. The inside of the can should be of bright metal.

This screen not only provides the electrical screening necessary, but prevents the valve heat from reaching the gang condenser and keeps the valve temperature itself at a minimum by the cooling effect of the draught up the chimney.

The main practical difficulty in providing a set with adequate ventilation lies in disguising the appearance of the outlet holes on the top of the cabinet. Some ingenuity is often needed, but if sufficient trouble is taken it can be done, and it is well worth while, for in addition to reducing frequency drift the general temperature is reduced and components are likely to have longer lives.

A radio-gramophone is particularly difficult to ventilate because the motor and turntable usually prevent one from placing the outlet holes above the set. The best thing to do then is to place the receiver right at the bottom of the cabinet and to fit a deflector plate above it to guide the hot air to an outlet at the top of the back of the cabinet. Alternatively, give the set itself a closed case with ventilation holes at top and bottom, and provide "chimneys" from the top holes to outlets at the top-back of the cabinet proper.

Even when all has been done that can be done in the way of ventilation there will still be some frequency drift with temperature. Even if there were no internal heating, there would still be changes in the ambient to consider. There is a considerable difference between an unheated room on a cold day and that same room an hour after lighting a fire!

Whether or not the drift so caused is important depends on the band-width and the signal frequency. On the medium waveband and with a moderately wide pass-band, it is not very important, except in push-button sets where the user cannot re-tune if there is excessive drift. On short waves with a narrow pass-band it can be very important.

Temperature compensation is often adopted in order to prevent changes in the ambient temperature and unavoidable

WIRELESS SERVICING MANUAL

internal heating from causing frequency drift. Normal components in the oscillator circuit have positive temperature coefficients; that is, their capacities and inductances increase with a rise of temperature. It is, however, possible to obtain condensers with a special dielectric having a negative temperature coefficient.

By including such condensers in the oscillator circuit it is possible so to balance the positive and negative temperature coefficients that the net coefficient for the circuit as a whole is zero. It is usually possible to do this only at one frequency, but by making this frequency towards the middle of the waveband a considerable reduction of drift over the whole band can be secured. In push-button sets of the type in which switching is used to select a different oscillator circuit for each station, individual compensation is possible on each station.

The temperature compensating condenser is sometimes made adjustable, but its adjustment is apt to be a rather lengthy business. After each alteration to it it is necessary to put the set through a complete cycle of temperature change in order to determine its effect. Such a cycle can hardly take less than an hour, and may be much more.

In general, if the set has been compensated correctly in the first place subsequent adjustments are needed only if a valve or component in the oscillator circuit has been replaced by one of different type. The compensation, therefore, should normally be left alone unless a drift test shows that its needs attention. Such a test should always be made, for excessive drift is a particularly annoying defect.

In addition to the slow changes of frequency produced by thermal effects, short period changes are often found. These are usually caused by variations in the voltages applied to the oscillator and mixer valves. For maximum stability the oscillator valve should be of high mutual conductance and very loosely coupled to the tuned circuit which should itself be of high Q. The amplitude of oscillation should also be kept as small as possible. As pointed out earlier, therefore, it is important that any methods adopted to secure an even oscillator output over the tuning range should damp the tuned circuit as little as possible.

Sometimes quite elaborate arrangements are made to achieve high stability, but the details of design are usually by no means obvious. With some circuits, for instance, it may well happen that an increase of voltage on one electrode of the valve may cause a reduction of frequency while an increase on another may

FREQUENCY-CHANGERS

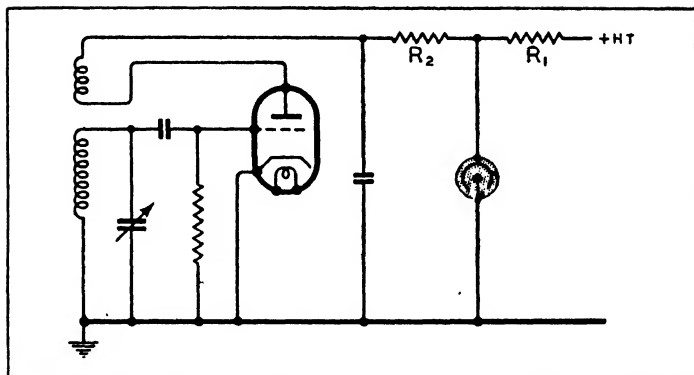

Fig. 81 : A simple neon-stabiliser for the oscillator H.T. supply often considerably improves the frequency stability

produce an increase. By proper choice of the feed resistances it can then be arranged that the change of voltage on one electrode is corrected by the change on the other, and a variation in the H.T. supply voltage produces no change of frequency. In such a case the circuit diagram gives no indication at all that the set has such compensation.

In general, compensation of this nature is rarely more than partial in broadcast receivers and variations of the H.T. voltage do affect the frequency to some extent. It is, of course, quite easy to stabilize the H.T. supply to the oscillator, for the voltage and current required by the valve are usually quite small. A neon tube can be used, as shown in Fig. 81. Special neon stabilisers are usually made to work at about 100 volts and are available for a number of different current ratings. One for some 10 mA. is generally suitable, and in such a case one would choose R_1 to drop the H.T. line voltage to 100 volts at 10 mA and R_2 to drop from 100 volts to the required oscillator voltage at the oscillator current.

As an example, suppose that the H.T. line is at 250 volts, and that the oscillator requires 5 mA. at 60 volts. With the above neon, R_1 must drop 150 volts at 10 mA., so it must be 15,000 ohms; R_2 must drop 40 volts at 5 mA. and must be 8,000 ohms.

The tube functions because it has a very low differential resistance with a relatively high D.C. resistance. If the H.T. voltage rises the current through the neon increases so much

WIRELESS SERVICING MANUAL

that the voltage drop across R_1 increases very nearly as much as the increase of H.T. voltage; the voltage across the neon, therefore, rises by a very small amount only.

The degree of stabilisation obtainable depends on the neon tube, but also on the value of R_1 , and it increases with R_1 . Ordinary neon lamps used for lighting can be employed if they can be obtained without the resistance which is usually fitted into the base. The working voltage must be found by trial, however, and it is sometimes as high as 170 volts.

Stabilisation of the oscillator anode voltage alone does not necessarily improve the frequency stability of a complete frequency-changer, however, for voltage changes on the mixer electrodes may affect the frequency in the opposite way to changes on the oscillator itself. Strictly, therefore, stabilisation of the whole H.T. supply to the mixer is desirable, but it is not always easy because the mixer takes a total current of 10-20 mA. at up to 250 volts. Generally speaking it is impracticable unless the H.T. line is at least 350 volts.

At the present time it is most unusual to find H.T. stabilisers in broadcast receivers, and the designer selects values for the various feed resistances on the frequency-changer to give the maximum stability. It is, therefore, unwise to change resistance values or the type of valve used, since although the performance in other respects may be unaltered or even improved, such changes may well affect the frequency stability.

Effect of A.V.C.

Some of the most serious effects on frequency stability arise through A.V.C. and their cause is often unrecognised. The oscillator frequency can be affected by the A.V.C. voltage both directly and indirectly. The direct effect arises when A.V.C. bias is applied to the signal grid of the mixer for it alters the space charge distribution in the valve, and hence the input capacity of the injector grid. It also changes the currents drawn by the various electrodes, and so the voltages applied to them.

The effect is usually less with mixers having an inner grid for the signal, such as the triode-hexode, than with those like the heptode in which the signal is applied to an outer grid. Nevertheless, it is the general practice wherever possible to avoid applying A.V.C. bias to the mixer. It is usually only in sets having an R.F. stage that one can avoid it, however, and in the smaller sets, with a mixer and one I.F. stage, A.V.C. must

FREQUENCY-CHANGERS

be applied to the frequency-changer if it is to be of any real use.

The indirect effect of A.V.C. on the oscillator frequency occurs even when A.V.C. is not applied to the mixer, and it occurs because the regulation of the H.T. supply is not perfect. Changes of A.V.C. bias vary the current drawn by the controlled valves, and so the load on the H.T. supply. The H.T. voltage thus varies by an amount depending on its regulation and the H.T. supply to the mixer varies, so affecting the oscillator frequency.

In the absence of a stabilised supply for the mixer, all one can do is to see that the mixer is fed from a point on the H.T. supply system at which the regulation is as good as possible. To this end, the oscillator is sometimes fed through resistance-capacity smoothing circuits directly from the output of the H.T. rectifier. Only the rectifier itself and the mains transformer are then common to all valves and the oscillator anode voltage is much less affected.

The effect of A.V.C. on instability often passes unnoticed because it is troublesome only on a fading signal. On such a signal the varying oscillator frequency results in distortion which is very like that caused by selective fading, and the cause is usually attributed to such fading.

In order to check a set for this effect a signal from a test oscillator should be applied to the input and its output varied over a wide range while continually checking the tuning. If the tuning varies with input, then the A.V.C. voltage is affecting the oscillator stability.

It is very important that the test oscillator be one in which the output control has no effect on frequency, for otherwise the test is completely useless. This rules out many otherwise excellent test oscillators, for in the cheaper types it is not uncommon to find that the output control affects the test oscillator frequency more than A.V.C. affects the set oscillator.

Lest it should be thought that too black a picture has been painted of the difficulties of achieving good frequency stability, it may be as well to add that although the effects described are always present their magnitudes are often unimportant at the lower frequencies. On the medium and long wavebands it is quite rare for frequency stability to be troublesome if the ventilation is adequate. Temperature compensation is adopted only in push-button sets in most cases. As the frequency increases so does it become more difficult to achieve adequate frequency stability, and above some 15 Mc/s all the effects become quite important.

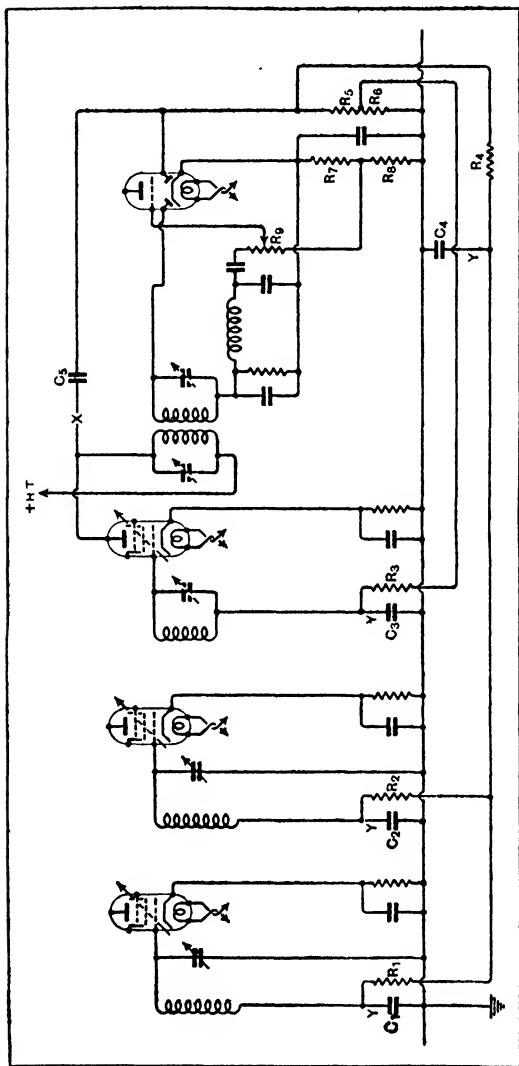

Fig. 82 : The delayed diode A.V.C. system is the most widely used. Three controlled stages are shown, but less bias is applied to the last valve than to the two before it

CHAPTER 16

AUTOMATIC VOLUME CONTROL SYSTEMS

MOST modern receivers include some form of automatic volume control, and although defects are quite rare, when they do occur they are usually rather obscure. In some cases, a defect will result in a loss of sensitivity, while in others severe distortion may arise. All A.V.C. systems in common use act on the same basic principle that the increase in detector input brought about by an increase in signal strength results in the application of a greater negative bias to certain valves. This reduces their amplification, with the result that the detector input rises less than it would do if the control were absent.

Although the ultimate aim of an A.V.C. system is the maintenance of a constant detector input irrespective of the signal strength it is obvious that this can never be achieved when the A.V.C. bias voltage is derived from the detector input, for if the detector input were always the same, the A.V.C. bias and hence the pre-detector amplification, would be also. In practice, therefore, the detector input does rise with increasing signal strength, but in a well-designed system it may rise by only 6 db. or so for an increase in aerial input of as much as 70 db. or more.

The most widely used method of obtaining A.V.C. is the delayed diode system, the usual connections for which are shown in Fig. 82. The precise arrangements employed differ from set to set, but all using this method of obtaining A.V.C. are basically the same. The output valve shown is a duo-diode-triode, in some sets a simple duo-diode is used, in others a duo-diode-output pentode, while the diodes are sometimes incorporated in the last I.F. valve. This is not important, because it is only the diodes that really matter as far as A.V.C. is concerned.

It will be seen that one diode is fed from the last I.F. transformer secondary and that its load resistance is returned directly to the cathode. This is the detector, and the A.F. potentials are taken off to the A.F. amplifier, in this case the triode section of the valve, from the slider of the volume control R_9 . The lower end of this resistance is taken to a point negative with respect to the cathode in order to obtain the correct negative grid bias.

A.V.C. is obtained from the other diode which is fed from

WIRELESS SERVICING MANUAL

the primary of the I.F. transformer through C_5 , which is usually of about $0.0002 \mu\text{F}$ capacity. Its load resistance comprises R_5 and R_6 in series and is returned to a point considerably negative with respect to the cathode, but which is also the correct point for returning the grid leads of the controlled valves. Considering Fig. 82 in the absence of a signal, it will be seen that the grid of each controlled valve is taken to the earth line through a series of resistances.

Grid Potential

As there is no current flowing through these resistances, the steady potential of each grid is the same as that of the earth line, and each valve has a negative grid bias with respect to its own cathode of a value depending upon the voltage drop across its own cathode bias resistance. Furthermore, while the triode section of the last valve is biased by its biasing resistance R_7 , the A.V.C. diode has a negative bias which is the sum of the voltage drops along R_7 and R_8 due to the anode current of the triode.

In some cases, R_8 is omitted, and the A.V.C. diode bias is then equal to the drop across R_7 alone. This A.V.C. diode bias is known as the A.V.C. delay voltage.

Now when a signal is tuned in nothing happens to disturb this voltage and current distribution as long as the peak I.F. input to the A.V.C. diode is less than the delay voltage, and the receiver functions just as if it were not fitted with A.V.C. When the input exceeds the delay voltage, however, rectification occurs in the A.V.C. diode circuit and a current flows through the diode load resistance (R_5 , R_6) in such a direction that the A.V.C. diode anode acquires a potential negative with respect to the earth line.

This potential is communicated to the grids of the two first valves through the resistances R_4 , R_2 and R_1 as increased grid bias, so lowering their amplification. Sometimes the grid return circuit of the last I.F. valve is also connected to this point, sometimes it is connected directly to the earth line and is not controlled. More often it is taken to a tapping on the A.V.C. diode load resistance as shown in Fig. 82; the A.V.C. bias applied to this valve is then less than the full voltage across R_5 and R_6 and is equal to the full voltage multiplied by $R_6/(R_5 + R_6)$.

This is done in order to prevent the last I.F. valve from being overloaded on a strong signal, for the maximum undistorted output obtainable from a screen-grid or R.F. pentode

AUTOMATIC VOLUME CONTROL SYSTEMS

valve is usually much less at a high grid bias than at a low. Where maximum immunity from such distortion is desired, the last valve is not controlled at all.

Defects in A.V.C. Systems

In some cases the A.V.C. diode is fed, not from the primary of the I.F. transformer as in Fig. 82, but from the secondary, and the diode feed condenser C_5 is then strapped between the two diode anodes. This arrangement is not much used nowadays, for the risk of distortion and sideband screech occurring when the set is mistuned from a station is greater.

Now it is clear that with such a simple A.V.C. system there is really very little that can go wrong, and it is for this reason that defects are rare. Since the delay voltage depends on the anode current of one of the valves in most cases—in Fig. 82 the triode section of the duo-diode-triode—a loss of emission in this valve will result in a lower delay voltage. A.V.C. will then cease to hold stations of different strengths at nearly the same volume and signals will be generally weaker.

The effects are, however, by no means so noticeable as the distortion arising in the A.F. amplifier through the defective valve, and the fault is more likely to be found while tracing distortion than while testing the A.V.C. circuit. In any case, the delay voltage will naturally be one of the first things to be checked in common with the other voltages.

The resistances associated with the A.V.C. circuit are usually of high value; R_1 to R_6 are often 0.5 megohm to 2 megohms each, so that a slight leak in one of the by-pass condensers or defective insulation of the A.V.C. line or grid circuits may materially reduce the A.V.C. bias applied to the valves. Thus, if R_4 is 1 megohm and C_4 develops an internal leak of 5 megohms, the bias actually applied to the valves controlled from this line will be five-sixths of the full voltage across the load resistance.

This would appreciably reduce the effectiveness of A.V.C., but would not in many cases be very serious. If the leak in C_4 were of 0.5 megohm, however, only one-third of the total voltage would be available and the performance would be greatly upset. Similarly, an internal leak in C_1 and C_2 would affect the results in like manner, as would also poor insulation in the grid circuits of any of the valves.

Another danger point is C_5 . Very high insulation is needed here, for one side is in connection with positive H.T. A small leak will slightly reduce the delay voltage actually applied to

WIRELESS SERVICING MANUAL

the A.V.C. diode and will not in itself be serious. It will result, however, in a positive bias being applied to the A.V.C. line in the absence of a signal, and this may offset the initial negative bias of the controlled valves sufficiently to promote instability. A heavy leak in C₅ results in the A.V.C. diode being continuously conductive, and the A.V.C. line takes up a slightly positive potential.

It is wisest to test for leaky condensers while they are in the set, as equipment for measuring resistances of over 1 megohm is not usually available. The feed-condenser C₅ is readily tested if a milliammeter be connected in the anode circuit, or a voltmeter be joined across the bias resistance, of one of the controlled valves. With no signal, disconnect C₅ from the anode of the preceding valve at the point X. If the anode current or grid bias of the controlled valve falls with C₅ disconnected, the condenser is definitely leaking and should be replaced.

In the case of the condensers in the A.V.C. line, the test is best carried out with a signal which is most conveniently obtained from a test oscillator. This can be set at any desired frequency, the set tuned to it, and the output set at a figure which gives a good deflection on a meter connected to any of the controlled valves. Then disconnect C₄ at Y; there should be no change in the meter reading. If the current falls, however, indicating an increase of A.V.C. bias, C₄ is leaking.

The other condensers, C₁, C₂ and C₃ can be tested in a similar way, but here it is necessary for the indicating meter to be connected to the particular valve concerned, and the test signal *must* be injected at a point following this valve. If this is not done, the removal of the condenser will affect the R.F. input to the detector and hence the A.V.C. voltage.

Although at one time nearly universal, this form of delayed diode A.V.C. is gradually falling into disuse because it causes a degree of amplitude distortion which can be quite considerable under certain conditions of signal strength and modulation depth. This occurs because the input resistance of a diode with negative bias on its anode varies with the input signal. With no signal it is infinite, and with a very large signal it becomes, in the limit, one-half of the value of the load resistance. There is, moreover, an abrupt transition from an infinite to a finite resistance when the signal changes from a value just below to a value just above the negative anode bias.

Now a modulated signal is one which is continually varying in amplitude and as it does so the input resistance of the A.V.C.

AUTOMATIC VOLUME CONTROL SYSTEMS

diode varies also, and jumps to infinity whenever the modulation makes the signal fall below the delay voltage. This input resistance damps the tuned circuit, and as it varies, the damping varies also. The gain of the I.F. valve consequently changes in sympathy. If the gain thus varies during the modulation cycle the modulation envelope is distorted, and the A.F. output from the detector is also distorted.

The amount of distortion depends on the relative circuit values, and it can be minimised by using high values for R_5 , R_6 , R_3 and R_4 in Fig. 82, together with an I.F. transformer for the last stage which has coils of low dynamic resistance. These conditions were often met in the older sets, but not in more modern designs. The use of iron-core coils has resulted in higher values of dynamic resistance, and at the same time, the resistances in the A.V.C. circuit have to be lower. This is because the maximum D.C. resistance in the grid circuit of most modern valves is limited to 3 megohms. If a resistance is common to more than one valve, its effective value per valve is its actual resistance multiplied by the number of valves.

If this rule is adhered to, the resistances sometimes become surprisingly low and the distortion correspondingly high. Alternative circuits are coming into use, therefore, and one of the most satisfactory is shown in Fig. 83. In this V_1 is the last I.F. amplifier and V_2 is a diode detector. The detector circuit is conventional with a filter comprising C_1 , C_2 and R_1 . The D.C. load is R_2 which is also the A.F. volume control, and the A.F. output is taken off through C_3 and R_3 . The detector circuit as a whole is biased positively with respect to the earth line by R_5 and R_6 , but maintained at earth potential to alternating currents by C_5 , which should be of large capacity. In general the diode circuit will be about 10 volts positive.

A.V.C. is taken off the diode load through R_4 , and C_4 is the usual filter condenser. Delay is provided by the positive bias on the detector circuit in conjunction with the diode V_3 . In the absence of a signal, the positive bias is applied to V_3 through R_2 and R_4 . This diode is conductive, therefore, and in effect short-circuits the A.V.C. and earth lines. As the signal gets stronger the detector output increases, and as it appears across R_2 , it is effectively in series with the positive bias voltage as far as V_3 is concerned. When it exceeds the positive bias the anode of V_3 becomes negative with respect to its cathode and the valve becomes non-conductive and has no further action. The voltage across R_2 , less the positive bias, is then applied to the A.V.C. line.

WIRELESS SERVICING MANUAL

As in the absence of a signal the controlled valves have their grids returned to earth only through their filter resistances and the diode V_3 , and as this diode is of low resistance, the limitation on the maximum permissible resistance values is somewhat less stringent. It is usually satisfactory to take the limit as 2 megohms per valve, for resistances between the grid of a controlled valve and the anode of V_3 .

The circuit is not quite free from a similar form of amplitude distortion to that found with the older arrangement. When the signal is less than the delay voltage, the D.C. load resistance of the detector diode V_2 is $R_1 + R_2R_4/(R_2 + R_4)$, whereas with a signal greater than the delay voltage it becomes $R_1 + R_2$. The change of resistance reflects on to the input tuned circuit and so alters the I.F. stage gain.

The distortion is usually much less than with the older circuit, however, and is minimized by making R_2 as small and R_4 as large as possible. In practice, the two diodes are usually

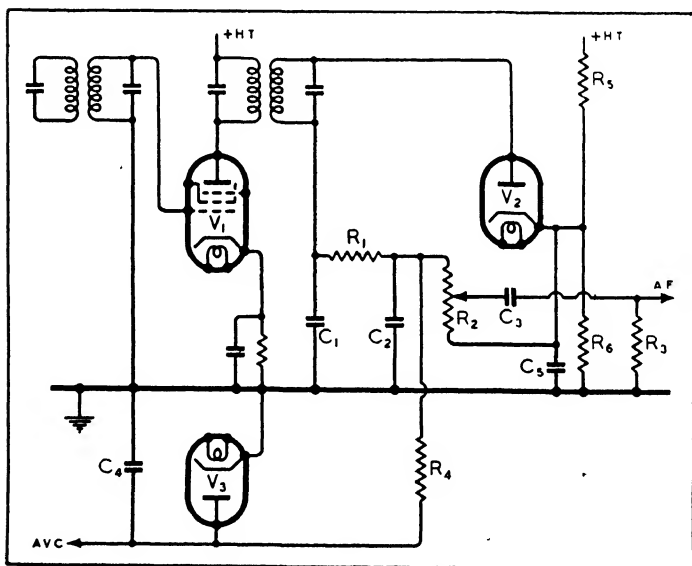

Fig. 83 : In this delayed diode A.V.C. system, V_2 and V_3 are usually the two valves of a duo-diode with separate cathodes. The circuit introduces less distortion than many others

AUTOMATIC VOLUME CONTROL SYSTEMS

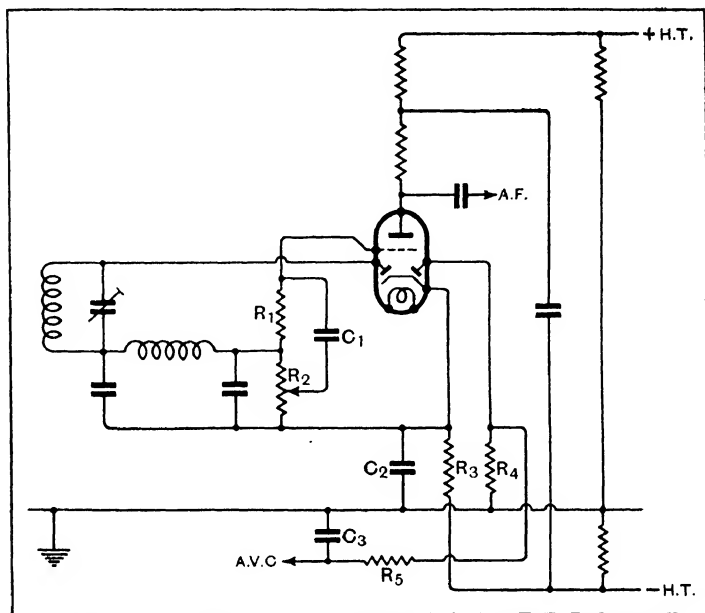

Fig. 84 : The D.C. amplified A.V.C. system gives very good control but is more critical in its operating conditions than more simple arrangements

the two halves of a duo-diode, but the valve must be of the type, such as the 6H6, having separate cathodes.

D.C. Amplified A.V.C.

D.C. amplified A.V.C. is used in some receivers because it gives much greater control than the more simple delayed diode system. It has the drawback, however, of being much more particular about its precise operation conditions. The basic circuit is shown in Fig. 84 and it will be seen that the circuit of the detector diode is normal, the load resistance R_2 also acting as a manual volume control. The triode section of the valve, however, has no fixed negative bias applied to it, but its grid is connected through R_1 , which is usually about 2 megohms, to the detector load resistance R_2 . When a signal is tuned in, a steady voltage nearly proportional to the I.F. input to the detector appears across R_2 and is consequently applied through

WIRELESS SERVICING MANUAL

R_1 to the triode grid as negative grid bias. The anode current of the triode consequently falls with increasing signal input.

In the absence of a signal, the circuit constants are chosen so that the cathode is positive with respect to the earth line and since the A.V.C. diode anode is returned to the earth line it is negative with respect to the cathode by this amount—the delay voltage—and is non-conductive. The A.V.C. line is thus at the same potential as the earth line.

When a signal is tuned in, the triode anode current falls as already explained, and the voltage drop across the cathode resistance R_3 falls also, so that the potential of the cathode comes nearer to that of the earth line. Nothing else happens until the signal is strong enough to bring the cathode potential below that of the earth line; that is, until the voltage drop across R_3 is less than the voltage between negative H.T. and the earth line.

The A.V.C. diode anode then becomes positive with respect to the cathode and this diode conducts. The A.V.C. line then takes up very nearly the same potential as the cathode and with increasing signal strength follows the cathode potential, becoming more and more negative with respect to the earth line.

The control obtained with a circuit of this nature can be very effective indeed. The detector, of course, must work at quite a small input of 1 or 2 volts only, otherwise the triode section of the valve, which works as an A.F. amplifier, in addition to being a D.C. amplifier for A.V.C. purposes, will be badly overloaded. Apart from leakages in the decoupling condensers which have the same effect as with Delayed Diode A.V.C., the chief troubles are likely to arise from a defective duo-diode-triode.

The A.V.C. Delay Voltage

It can be seen that quite small changes in values will affect the operation, for the A.V.C. delay is large and depends entirely on the anode current of the valve. A common value for R_3 is 20,000 ohms and the anode current may be 4 mA; the cathode potential is then 80 volts above negative H.T. The voltage between negative H.T. and the earth line may be 50 volts, so that the delay is 30 volts. Suppose now that the valve only passes 3.5 mA without a signal, the delay falls to $70 - 50 = 20$ volts; the performance of the receiver would obviously be affected.

A serious loss of emission would render the set practically useless. If the anode current, in this case, fell to 2 mA through

AUTOMATIC VOLUME CONTROL SYSTEMS

such a cause, the cathode potential would be only 40 volts above negative H.T. and would be 10 volts negative with respect to the earth line. All the controlled valves would then receive an initial bias of nearly 10 volts which would increase still more on tuning in a signal.

The set would naturally prove very insensitive and would probably fail to receive anything but a local station. When testing a set fitted with this form of A.V.C., therefore, it is particularly important to investigate the operating conditions of the duo-diode-triode which provides A.V.C.

A few receivers employ I.F. amplified A.V.C. In this system, a conventional delayed diode A.V.C. circuit is employed but preceded by a stage of I.F. amplification which operates to feed the A.V.C. diode only and is not in the chain leading to the detector. The usual connections are illustrated in Fig. 61 and the possible defects in practice are those of the delayed diode system with the addition of those likely to occur in any stage of amplification.

In some receivers, metal rectifiers are used in place of valve diodes. The circuits are essentially the same, and fault finding consequently follows the same laws. It should be remembered, however, that the internal resistance of a metal rectifier in the "non-conductive" direction is by no means infinite and in many cases this has the effect of reducing the initial bias of the controlled valves below the voltage set up across the bias resistance.

In sets using such rectifiers one should be prepared to find that the apparent initial bias, as measured across the bias resistance, is higher than is usual for the type of valve used, for the designer will have raised the value of the initial bias resistance in order to compensate for the leakage current of the rectifier.

Q.A.V.C.

Turning to Q.A.V.C. systems, these are so varied that it is hardly possible to deal in any detail with the defects which may be encountered. Basically, the muting circuits are simple, but many are highly complicated in their detail and as there is no approach to standardization it is usually necessary to analyse each case on its merits. In practically all cases muting is obtained by arranging for a valve to apply a large bias to the last I.F. valve, the detector, or the first A.F. valve in the absence of a carrier, so that the stage is rendered inoperative.

The I.F. valve is not often silenced, for although it is from

WIRELESS SERVICING MANUAL

many points of view the ideal arrangement, it demands the duplication of this stage and so it is more expensive.

One of the simplest systems is shown in Fig. 85 and if the operation of this be fully understood little difficulty will be found with other arrangements of similar type but of different detail. The last I.F. valve is of the R.F. pentode-duo-diode type and provides delayed diode A.V.C. in the usual way, the A.V.C. bias available after the usual filter ($R_2 C_1$) being applied to the grid of the muting valve V as well as to the early stages of the receiver.

The detector circuit is normal save for the connection to the anode of V and for the return of the cathode circuit to the potentiometer across the H.T. supply instead of to the earth line. It is clear from the drawing that the grid bias of V is the potential between the slider of R_4 and the earth line plus any A.V.C. bias, while the H.T. supply for this valve is the voltage between the slider of R_4 and the diode cathode. The total voltage across R_4 is usually about 40–80 volts.

Negative Bias on the Diode Anode

Now it can be seen that if the voltages on the muting valve are such that it passes no anode current, it has no effect on the operation of the receiver. If the voltages are such that the valve does pass current, however, there will be a voltage drop across R_1 , which is the diode load resistance. The anode of V will consequently be negative with respect to the diode cathode and as the diode anode is in connection with it, it will be negative with respect to its own cathode. The diode anode is thus biased negatively and rectification cannot occur as long as the signal is smaller than the bias.

In normal operation, the slider on R_4 is adjusted in the absence of any signal to such a position that the detector is rendered just inoperative. The valve V is then passing just enough current to bias the diode by 1–3 volts. When a signal is tuned in, V receives an increase of grid bias from the A.V.C. system, and if it be large enough its anode current will cease and the bias on the detector will disappear so that correct operation is secured.

If the A.V.C. bias is not great enough completely to cut off the anode current of V , the detector bias will be only partially removed, with the result that the detector will operate only inefficiently and with severe distortion.

It can be seen that for any setting of R_4 , there is a range of signal strengths over which the muting is only partially realised

AUTOMATIC VOLUME CONTROL SYSTEMS

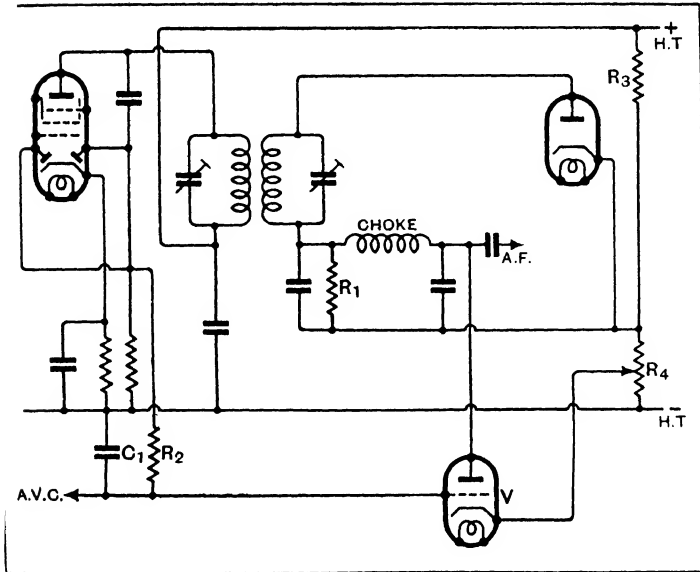

Fig. 85 : A simple method of obtaining Q.A.V.C. with a diode detector

and over which distortion occurs. This is inevitable and the aim in design is to make the range as small as possible and to make it occur only on weak signals which are not usually of much importance. Q.A.V.C. is consequently a fitting which is of doubtful value in all but very sensitive receivers.

The faults which can arise in an arrangement such as that of Fig. 85 are very few and are really limited to the D.C. voltage supplies, which can be readily checked with a voltmeter, the valve itself, and the A.V.C. feed. In certain modifications, decoupling is included in the anode circuit of the muting valve and there is, of course, then the additional possibility of a defect in these components.

There are many other Q.A.V.C. systems employed and they are too numerous to be treated in detail here. They all operate upon the same basic principles, however, and it is usually quite easy from an inspection of the circuit diagram to see how they work and to devise suitable testing methods for any particular case.

CHAPTER 17

SHORT-WAVE RECEIVERS

DISSATISFACTION is often expressed with short-wave apparatus of the best design and in good condition, because the user fails to realize the different conditions existing on the short and the ordinary broadcasting bands. Filled by the expectation of enjoying programmes from the Antipodes, to say nothing of America, the newcomer to short-wave reception is often severely disappointed and believes the equipment to be faulty, but as often as not there is nothing wrong with the receiver.

It must be realised, first of all, that the chief programmes broadcast by other countries occur, like ours, in the evening. Eight o'clock in America, however, is roughly 1 a.m. in this country, and the same hour in Australia corresponds to eleven o'clock in the *morning*. It usually happens, therefore, that during the normal listening hours, the programmes from distant stations are not at their best, and many stations are not transmitting at all. Before trying to receive a particular station, therefore, it is wise to consult a list of stations to make sure that it is working.

In the second place, one must not forget that the effectiveness of different wavelengths varies with the time of day and year. In general, reception above 30 metres is better after dark than during the daylight hours, but the converse is generally true of wavelengths below 20 metres. The band between 20 metres and 30 metres is often at its best around sunset.

These figures for wavelengths are naturally very approximate and considerable variations are often experienced. Freak conditions occur when totally different results are obtained, but on the average they give a good guide to what one may expect.

Variable Reception

This question of wavelength is well worth bearing in mind when it is desired to hear a particular programme from, say, America. It often happens that the same programme is broadcast from several different stations and the one which is received best depends largely upon the time of day. During the daytime, the American stations on about 16 metres are generally the best heard. Towards evening stations around 19 metres begin to come in, and are often very good indeed for

SHORT-WAVE RECEIVERS

about an hour before and after sunset. Sometimes good reception will continue throughout the evening, but at others it is necessary to go to higher wavelengths for good results once darkness has fallen.

In addition to this question of wavelength it is necessary to realise that conditions on short waves change very greatly and very rapidly. At one time, it may be possible to receive American stations with a degree of quality and volume suggestive of the best Continental transmissions on the medium waveband ; a few hours later conditions may have changed so much that no Transatlantic stations are audible, or fading may set in which is so severe that the programme becomes unintelligible.

This may seem rather a black picture of short-wave reception, but the author wishes to emphasise the disparity between the conditions of ordinary broadcast reception and those existing on short waves. There is no doubt whatever that at times reception of entertainment value can be obtained from the most distant stations, and most days intelligible reception is possible from at least a few American stations provided that the time and wavelength be properly chosen. Reception is, however, unreliable to a degree almost unknown on the longer wavelengths. When testing short-wave equipment, therefore, it is not always easy without an extended test to determine whether or not the apparatus is functioning correctly, and it is always advisable when possible to have another receiver available so that a direct comparison can be made.

Like all other receivers, short-wave sets can be divided into the two categories of straight sets and superheterodynes. The latter are now by far the more widely used, particularly with medium and long wave ranges incorporated, when they are really all-wave sets. The straight set is by no means dead, however, and many are still in use. It is almost impossible to obtain any useful degree of selectivity at signal frequency without making full use of reaction and, in general, this full use of reaction cannot be realized with a tuned R.F. amplifier. The majority of S.W. straight sets, therefore, are of the det.-A.F. type, but some have one R.F. stage. They rely chiefly on reaction both for their sensitivity and for their selectivity. It is, therefore, very important to obtain reaction which is smooth and free from overlap. This is not always easy, but it is essential if the receiver is to be of any real use.

In order to obtain satisfactory results, the tuning condenser must be of high quality and fitted with a good slow-motion dial free from any trace of backlash. For a purely short-wave

WIRELESS SERVICING MANUAL

receiver, the capacity of the condenser should not exceed $0.00016 \mu\text{F}$. and for an all-wave set, in which some compromise between conflicting requirements is inevitable, $0.00036 \mu\text{F}$. The reaction condenser should be equally good mechanically and of the air-dielectric type with a capacity of some $0.0002 \mu\text{F}$, it is best fitted with a reduction ratio drive.

Now when the components are satisfactory, from a mechanical point of view, the smoothness of reaction depends entirely upon the electrical constants, and the valve, the circuit, and the operating voltages are all important. A typical detector circuit is shown in Fig. 86 ; it may be followed by any conventional A.F. amplifier, and the choice of a suitable valve is quite important.

The type of valve has very little effect upon the efficiency of detection, for this is almost entirely a matter of the grid circuit. As far as detection is concerned, the grid and cathode form the only important electrodes and the action is that of the conventional diode detector. As a result of detection, A.F. potentials appear on the grid of the valve, and for these the valve acts as a conventional A.F. amplifier. Since there is little

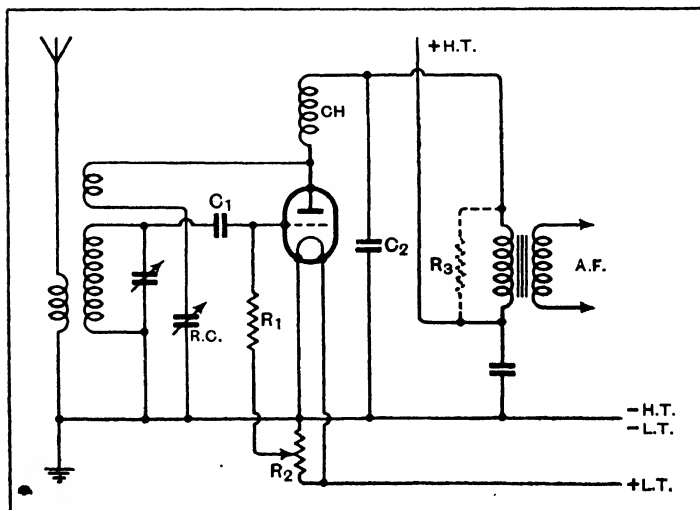

Fig. 86 : The detector circuit of a typical short-wave receiver

SHORT-WAVE RECEIVERS

difference between the grid circuit characteristics, as regards their effect on the efficiency of detection, of valves of widely different triode characteristics, it would seem that the best valve to choose would be the one which will give the greatest gain as an amplifier. In S.W. receivers only small signal voltages are involved, so that this would be true if reaction had not to be considered.

The R.F. potentials applied to the grid affect the anode current, and by means of the reaction coil a suitable amount of energy is fed back to the grid circuit. The effect is very nearly the same as if the R.F. resistance of the tuned circuit were reduced. As reaction is increased the effective resistance falls and signal strength increases, but stability is maintained as long as the total resistance is positive. As soon as the resistance becomes zero or negative, oscillation commences.

When receiving telephony, the resistance should always be positive, but for weak signals as near to zero as possible. Very high gain is obtainable by means of a correctly adjusted reaction circuit, and the importance of correct adjustment will be realised when it is said that although it is possible to obtain amplification of several thousand times in this way, a badly adjusted circuit may give a gain of no more than ten times.

Influence of Reaction

The influence of reaction on the choice of the valve now becomes apparent. If the valve is chosen with a high amplification factor to give maximum A.F. amplification, the best valve is unlikely to give more than three times the gain of one of lower mutual conductance. It may happen, however, that the valve which is apparently the poorer enables smoother reaction to be obtained, and this permits one to approach the oscillating point more closely and reaction is more effective. The value of reaction might easily be increased ten times, and this would more than offset the lower A.F. amplification, and the apparently poorer valve would give the better results.

In general, the detector valve should have an A.C. resistance of 10,000–15,000 ohms and a moderate mutual conductance—1–1.5 mA/V is ample. The anode voltage should not be high, and in most cases 60 volts is sufficient; in some a lower voltage is better but it should always be adjusted by trial and error.

The grid leak and condenser are also important. The condenser does not normally require critical adjustment and a value of 50–100 μF is satisfactory, but the grid leak should be of fairly high value. It is not, however, the value of the grid

WIRELESS SERVICING MANUAL

leak which is so important as the potential at which the grid is maintained and this depends not only on the grid leak but on the point to which it is returned. In general, and within limits, the higher the resistance of the grid leak and the less positive the point to which it is returned, the smoother the operation of reaction.

The best results are usually secured with a grid leak of 1-2 megohms returned to the slider of a potentiometer connected across the filament (R_2 , Fig. 86). When the slider is at the positive end reaction will usually be "ploppy," but it will be quite smooth at the negative end. For the greatest sensitivity, the slider should be set as near to the positive end as possible while keeping reaction quite smooth. This usually means that the slider will be set at about one-quarter to one-third of its travel from the negative end. Where no such potentiometer is fitted, the grid leak must be taken to the positive side of the valve filament, and to obtain smooth reaction a higher value of grid leak will often be needed, usually 2-5 megohms.

When using indirectly heated valves no positive bias is needed, for grid current flows until the grid is more negative than about 1 volt. Owing to this, it is often necessary with such valves to apply a small negative grid bias of perhaps 0.5 volt. This is most easily done by adopting the connections of Fig. 87, in which R_2 is the bias resistance. It should be adjustable and can have a maximum value of some 500 ohms. Adjustment is carried out in the same way as with the potentiometer of a battery set, bearing in mind that an increase in the value of the resistance corresponds to moving the slider of the latter towards the negative end.

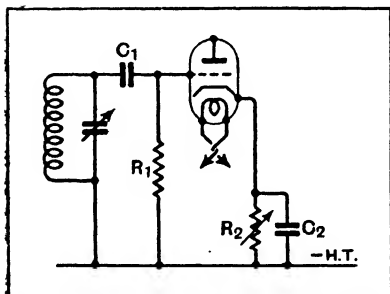

Fig. 87 : With indirectly-heated valves, a small negative bias is often an aid to the attainment of smooth reaction

It often happens that threshold howl prevents proper reaction effects from being secured, for when reaction is adjusted to the oscillation point a growl or howl appears. There are several causes of this trouble, but one of the commonest and the most often overlooked is the nature of the anode circuit load impedance at low

SHORT-WAVE RECEIVERS

frequencies. In order to avoid threshold howl this must not be highly inductive. When transformer coupling is used, the primary is an inductance and threshold howl is common. It sometimes happens, of course, that no trouble is experienced, probably owing to the primary being damped by the losses in the transformer, but with good quality modern transformers it is very likely to occur. The remedy is to shunt the transformer primary with a resistance of some 10,000-20,000 ohms (shown dotted at R_3 in Fig. 86), and thus damp it artificially. This resistance naturally lowers the A.F. amplification, but just as in the case of the valve, the improvement in reaction more than outweighs the loss in most cases.

R.F. Currents in the A.F. Circuits

The second common cause of threshold howl is merely the presence of R.F. currents in the A.F. circuits and this is a prevalent cause also of hand-capacity effects, particularly when telephones are used. The remedy is to use adequate filtering after the detector. The condenser C_2 should always be included and can usually be about $0.001 \mu\text{F}$. When the resistance R_3 is used, a larger capacity can be employed without affecting the quality of reproduction and C_2 can then be about $0.002 \mu\text{F}$, and sometimes as high as $0.005 \mu\text{F}$.

In many cases, a resistance in place of the choke Ch will give better filtering. A suitable value would be 20,000 ohms, but as the anode current flows through it, a higher H.T. voltage will be needed, and it may have an effect upon the smoothness of reaction.

When the circuits have been correctly adjusted for reaction, it may be found that although results are satisfactory over a portion of the tuning range there are dead-spots at which the reaction has to be greatly advanced before oscillation can be secured or at which no oscillation at all can be obtained. There are two causes of this—the aerial and the R.F. choke Ch . If the latter be responsible, the trouble will persist with the aerial removed, and the remedy is either to use a better choke or to replace it by a resistance, with which the effect does not occur.

With a circuit such as that of Fig. 86, where the aerial is coupled to the circuit to which reaction is applied, dead-spots are inevitable when the aerial coupling is tight. They occur when the tuned circuit is resonant at harmonics of the natural frequency of the aerial, and the remedy is to loosen the aerial coupling. It will then be too loose for the best results at other

WIRELESS SERVICING MANUAL

frequencies, so that with a receiver of this nature the aerial coupling should be adjustable by means of a panel control. This naturally complicates the tuning, and it is consequently common practice to include an R.F. stage largely for the purpose of isolating the tuned circuit from the aerial. Dead-spots cannot then occur and one rather troublesome control is avoided; furthermore, the calibration of the set is unaffected by the aerial, and radiation from the aerial is reduced if the set is operated in an oscillating condition, while the stage may give some small degree of amplification.

The Aerial Circuit

The receiver then takes the form of Fig. 88 and is a very considerable improvement over the simpler set. It might be thought that it would be advantageous to tune the aerial circuit, but this is not always the case. In the first place, ganging would be difficult unless the aerial coupling were loose, for the same effect that produces dead-spots with the simple detector circuit would cause mis-ganging at certain wavelengths. Secondly, although such troubles could be avoided by using a separate tuning control, this would render operation more difficult. Thirdly, serious difficulty from instability might be found if the R.F. stage gave any useful degree of amplification; and fourthly, reaction would probably be less effective. This last is the most serious drawback and is a defect almost inherent in any receiver embodying both R.F. amplification and reaction.

As reaction is increased in such a set, the R.F. stage comes nearer to a state of instability, and the R.F. valve may start oscillating before the detector. The amplification thus becomes critically dependent upon the operating conditions of both R.F. and detector valves and upon the precise tuning of all circuits. Tuning then becomes very difficult if the highest sensitivity is required.

This does not, of course, mean that a tuned aerial circuit is impossible, but merely that it is not usually worth while, and the arrangement of Fig. 88 is consequently generally adopted. There is only one difficulty which is likely to occur with this arrangement and this only when the set is used near a medium-wave broadcasting station. Cross-modulation may then occur and the programme of the local station be superimposed on every station received, although in the absence of a signal no trace of the local station will be evident. This trouble is usually a sign that the aerial choke Ch 1 is of too high an inductance and is resonating the aerial circuit in the broadcast band. The

SHORT-WAVE RECEIVERS

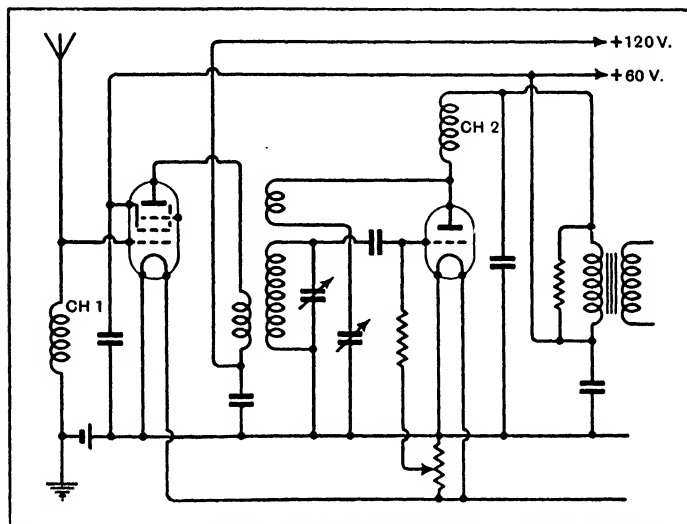

Fig. 88 : The use of an R.F. stage is advantageous in avoiding " dead-spots "

use of a choke of lower inductance will usually effect a cure without affecting the performance on short waves.

The second class of short-wave or all-wave receivers—the superheterodyne—is really no different from its medium- and long-wave counterpart. It can develop the same troubles and the same remedies apply. It is, therefore, hardly necessary to treat such sets here, for the information given in other chapters dealing with testing applies equally to this case. The design of short-wave superheterodynes is, of course, quite another matter, but that is a subject which cannot be treated here.

There are, however, certain features of some short-wave superheterodynes which deserve mention, for although they are not inherently peculiar to short-wave sets, in practice they are rarely found in any other set. Short-wave sets of the so-called communication type, for instance, often include a beat-frequency oscillator and sometimes a crystal-filter in the I.F. amplifier. They are both used primarily for the reception of C.W. Morse signals.

Beat-Frequency Oscillator

The beat-frequency oscillator consists simply of an oscillator

WIRELESS SERVICING MANUAL

tunable by a panel control over a range of some ± 3 kc/s about the mid-band frequency of the I.F. amplifier. It is coupled in some way to the I.F. amplifier, but the coupling is not usually adjustable.

In addition to the panel control, a trimmer is generally provided for adjusting the frequency. This is adjusted while aligning the I.F. amplifier. When the other adjustments have been made and with the test oscillator giving a fairly small signal, switch on the B.F.O., set its panel control to the mid-point of its range, and adjust the trimmer to zero beat. Then swing the panel control on either side of its mid-point and check that the beat notes at each limit of travel are about the same.

If they are not the same, set the control a little off zero beat on the side giving the greater range, and readjust the trimmer for zero beat. Having found in this way the electrical mid-point, the setting should be marked on the panel, for it is the correct setting for the B.F.O. control while tuning the set.

Defects in the oscillator itself are likely to be no different from those in any other oscillator. Screening is important, however, for if it is inadequate harmonics may reach the input circuits and give rise to spurious signals. On short waves, however, the order of harmonic involved is so high that trouble is unusual.

The output of the B.F.O. is important, for it is necessary that the voltage applied by it to the detector be larger than the biggest signal voltage. If it is less than the signal, the A.F. output will depend on the B.F.O. voltage and not on the signal.

Now this requirement introduces complications when the detector is designed for large signals. For instance, if the normal detector input is 10 volts or more—the A.V.C. delay being 10 volts—the B.F.O. injection must be at least 15–20 volts. Even in the absence of a signal, this will produce 5–10 volts A.V.C. bias, with the result that the set will be very insensitive. In order to overcome this, A.V.C. is switched off in some sets when the B.F.O. is brought into use. Unless the oscillator stability in the frequency changer is very good, this is not as great a drawback as it sounds, for in C.W. reception even a trace of frequency instability with A.V.C. is likely to be very noticeable.

When A.V.C. is desired, however, and it is not possible to resort to the complication of using a separate A.V.C. amplifier fed from the last I.F. valve grid, so that the B.F.O. can be injected at the detector without affecting A.V.C., a compromise

SHORT-WAVE RECEIVERS

is adopted. The A.V.C. system is given little or no delay, the detector is designed for a small input—1 or 2 volts only—and the B.F.O. injection is made quite small. It is made of the same order or less than, the delay voltage. The B.F.O. then reduces the sensitivity by only a small amount, or not at all, and the performance on weak signals, which produce a voltage at the detector less than that of the B.F.O., is good. Strong signals, however, produce little or no greater output, and sometimes give somewhat less. In fact, the low B.F.O. injection produces something of a limiting action.

The value of the injection is easily checked and in the same way as the amplitude of the oscillator injection in a frequency-changer. In fact, the B.F.O. and the detector together actually form a frequency-changer. With no signal, connect a meter in series with the diode load resistance and note the change of current when the B.F.O. is switched on. The injection is about 1.2 times the product of the current change and the load resistance.

With small injection no serious difficulties arise, but in cases where it is large, it is often difficult to get sufficient coupling without making it so tight that the I.F. and B.F.O. circuits pull each other. Some form of electron-coupled B.F.O. is sometimes adopted to avoid this, but an alternative is to couple the B.F.O. very loosely indeed to the grid of the last I.F. valve.

One very convenient arrangement for small injection is to use a duo-diode-triode for detector and B.F.O. The diodes act as the detector and the triode as the B.F.O., while the valve capacities provide the coupling.

Crystal Filters

Another, but somewhat less common, feature of a communication receiver is a crystal filter. The precise circuit details differ from set to set, but the arrangement is generally on the lines shown in Fig. 89. The differences lie chiefly in the form of the crystal output circuit. In Fig. 89 it is apparently the resistance R , but if this is of high order, it is actually the input capacity of V_2 , and R is merely a grid leak. Sometimes a tuned circuit is used and then R is unnecessary. R is also sometimes replaced by the primary of a transformer of which the secondary feeds V_2 .

Whatever the precise details, the method of adjustment is much the same in all cases. Strictly, the adjustment of the crystal-filter is part of the normal operation of the set and not peculiar to maintenance, and the only control C_2 is, in fact, a

WIRELESS SERVICING MANUAL

panel control. The presence of the crystal does, however, complicate the I.F. alignment and it is necessary to deal with this in some detail.

Before doing so, it may be as well to describe how the crystal is used in operation, for it is not such a common circuit that it will be familiar to all. First, a word of warning. If the crystal-filter appears to do little or nothing on its first trial, do not immediately conclude that it is defective. Everything depends on the adjustment of C_2 , and some little skill is needed to adjust this control properly.

The tuned circuit LC_1 , the crystal, and C_2 are in the form of a bridge in which C_2 is the variable element for balancing. It is normally adjusted so that it balances the shunt capacity of the crystal holder. Apart from the piezo-electric properties of the crystal itself, the bridge is balanced and there is no output at any frequency. The crystal, however, behaves as a series resonant circuit of very high Q . At resonance it behaves as a resistance of moderate value, the bridge is unbalanced, and at this frequency the signal is passed to the output. For quite a small frequency difference from resonance the crystal becomes substantially a high reactance, the bridge is nearly balanced, and the output very small. The effective band-width is very small and depends upon the crystal itself as well as upon the output circuit. It is usually of the order of 50 c/s to 500 c/s.

It will be clear, therefore, that the circuit is not very suited to telephony, and it is intended primarily for C.W. Morse reception. It can be used for telephony, however, particularly if the balance of the bridge is upset slightly in the manner to be described later.

If the condenser C_2 is not set to the right value for balancing the bridge, the crystal will have very little effect. The best thing to do then is to set C_2 for minimum background noise, since this usually occurs with minimum band-width and this in turn occurs when the bridge is balanced.

Even if the bridge is still not quite balanced, it should now be possible to determine the setting of the tuning control corresponding to the crystal frequency, for when tuning through a signal a small "bump" should be heard as the intermediate frequency passes over the crystal frequency. By taking this as a guide, it is easily possible by small adjustments to C_2 so to balance the circuit that the signal disappears except at the one critical setting of the tuning control.

Signals should now tune-in very sharply, and telephony will be very deep toned; if the filter is of a very selective type,

SHORT-WAVE RECEIVERS

speech may well be unintelligible. There will also be a considerable apparent loss of sensitivity. It is a real loss on telephony, because of the severe sideband cutting, but it is only an apparent loss on C.W. and occurs through the drop of background noise.

One peculiarity of the high selectivity should be noted. It is imperative to tune-in a signal with the B.F.O. at the same frequency as the crystal resonance. The signal should be tuned to zero beat, and then the B.F.O. adjusted to give the required beat note. If one tries to tune with the B.F.O. already offset, tuning will be confusing. It may be impossible to tune to zero beat, there will be one setting only of the tuning control at which the signal is audible and this may not coincide with the correct setting for maximum signal with the B.F.O. properly adjusted.

If there is any difficulty in setting the B.F.O. to the crystal frequency, tune-in some signal and adjust the B.F.O. control while rocking the tuning control slightly until the combination of settings giving the loudest beat note is found. The signal is then properly tuned to the crystal, and by turning the B.F.O. to zero beat it can also be set to this frequency. It is a good plan to mark the setting.

Unbalanced Filter

The balancing control, or phasing control as it is sometimes called, is a panel control because it is often useful to work with the bridge slightly unbalanced. The resonance curve is then asymmetrical, but has a very deep crevasse on one side. By tuning so that this crevasse falls on an interfering signal, it may often be eliminated. If interference is found, therefore, it is as well to try unbalancing the bridge slightly, and it will usually be possible to find a critical setting of C_2 at which the interference disappears. This is especially useful in telephony reception, for even a bad heterodyne whistle can be eliminated. On account of the unbalanced condition of the crystal, the frequency response is usually good enough for intelligible telephony. There is often some amplitude distortion, however, because the asymmetric resonance curve makes reception almost single-sideband.

Turning now to I.F. alignment, the important thing is to make sure that the I.F. circuits are so adjusted that the mid-band frequency is the same as the crystal resonance frequency. In all other respects it is entirely normal.

WIRELESS SERVICING MANUAL

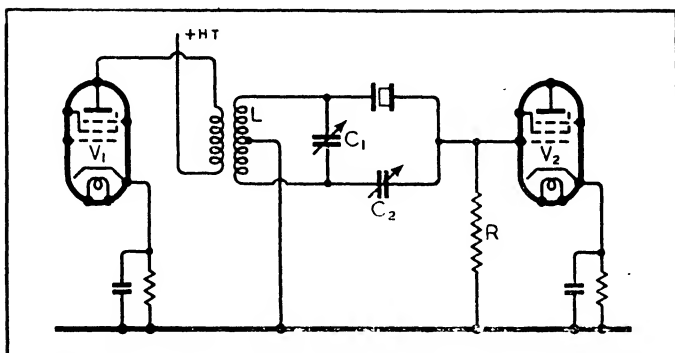

Fig. 89 : For extreme selectivity a quartz crystal is sometimes used. The capacity of its holder is neutralised by adjusting C_2

The nominal crystal frequency is usually known, and its actual frequency is unlikely to differ from it by more than 2 kc/s. It will, therefore, be within the pass-band of an I.F. amplifier adjusted to the nominal frequency. If the accuracy of calibration of the test oscillator can be relied upon to within 2 kc/s at the intermediate frequency, the best course is to align the I.F. amplifier roughly to it. Then bring the crystal into circuit, adjust the balancing condenser, and tune the test oscillator to the crystal. It will usually be necessary to use the test oscillator without modulation and to have the B.F.O. on when doing this. Nearly all test oscillators, and many expensive signal generators, have too much incidental frequency modulation for them to be of any use in the modulated condition with sharp crystal filters.

Having got the oscillator set to the crystal frequency, normal I.F. alignment procedure applies. Circuits associated with the crystal filter are usually adjusted simply for maximum output with the crystal in circuit and in the balanced condition.

There are other types of crystal filter to that shown in Fig. 89, but they are not often met. They are chiefly more complex structures designed to give a band-pass effect. Some of them are quite difficult to adjust and need special equipment. In view of their rarity, they need not be discussed here.

CHAPTER 18

SHORT-WAVE CONVERTERS

ALTHOUGH not commonly used now, short-wave converters were quite popular a few years ago and they are still met at times. A properly designed converter used with a good receiver is capable of giving a very fine performance indeed, but poor apparatus is naturally unsatisfactory. Unfortunately, a good converter is not cheap and many employ types which suffer from inherent defects which it is rarely possible to cure without radical alteration. When dealing with such apparatus, therefore, one must be careful to distinguish between those faults which are inherent to the design and those which are the result of a defective component. The latter are, of course, no different from those which may occur in other equipment and can be found by the application of the usual testing methods.

One of the commonest arrangements used in the older converters is a single valve, often a triode but sometimes a tetrode or pentode, connected to function as an oscillator. The only tuning control is the variable condenser controlling the oscillator frequency, so that the system has the advantage that no ganging is required.

From the performance point of view, however, the arrangement is not good, for there is no protection whatever against second-channel interference nor from any of the other forms of interference peculiar to the superheterodyne. Every station can be received at two different dial settings, in consequence. The efficiency is also generally of a low order and the signal to noise ratio not very high.

The greatest fault of all, however, and it is the greatest because it annoys not the owner but his neighbour, is the very serious degree of radiation from the aerial which occurs with converters of this type. The amount of interference which can occur on the medium waveband from an oscillating detector set is well known, but it is not generally realised that the autodyne converter is in no way better. Actually, it is often much worse, and serious interference with other short-wave receivers within a radius of ten miles or so may occur.

More modern types of converter often use a heptode, octode, or triode-hexode valve for frequency-changing. The triode section functions as the oscillator, but is separated from the aerial circuit by the internal screening of the valve. Provided

WIRELESS SERVICING MANUAL

that the construction of the apparatus is such that there is negligible stray coupling between the signal and oscillator circuits, therefore, radiation should be negligible.

Converters of this type thus offer a big improvement over the older ones, but the gain in the matter of performance is not so evident. The efficiency is usually higher, it is true, but there is still no protection against second-channel interference, for in many cases there is no signal-frequency tuning. Oscillator harmonics are also troublesome, and it is no uncommon thing for one station to be receivable at six different points in the tuning range, two points for the oscillator fundamental frequency and two each for the second and third harmonics.

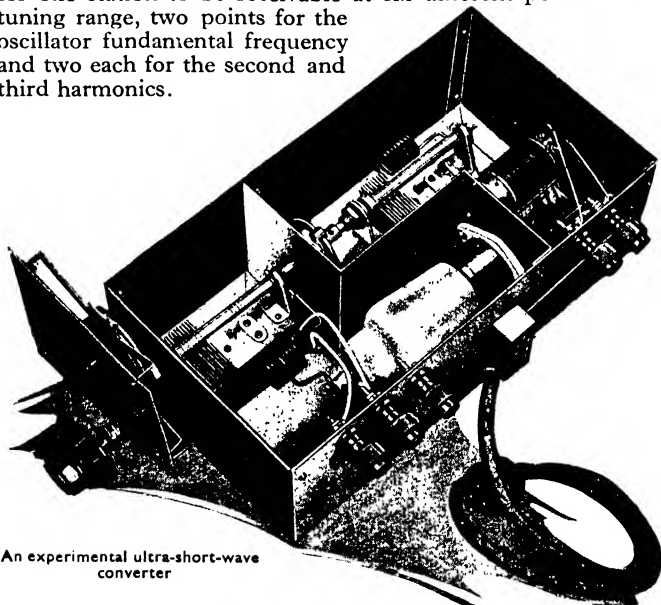

An experimental ultra-short-wave converter

If short-wave reception is to be anything more than a play-thing, it is essential for signal-frequency tuned circuits to be included, for only in this way can the interference troubles be avoided. The type of converter employing the triode-hexode, heptode, or octode and one signal-frequency tuned circuit is capable of a much better performance. The efficiency and the signal-noise ratio are both considerably increased; there is some discrimination against second-channel interference, but not a great deal. The selectivity of the signal circuit is great

SHORT-WAVE CONVERTERS

enough to remove most other sources of interference, however, so that in practice there is a big improvement.

Unfortunately, the addition of such a circuit considerably increases the cost of the converter, for not only have additional coils and a gang condenser to be provided, but the complications of ganging ensue. Nevertheless, for serious short-wave listening, signal-frequency tuning is essential and for the best results two tuned circuits are needed in addition to the oscillator. An R.F. valve is then included and there is a further very considerable gain in amplification and in signal-noise ratio. With two good tuned circuits, second-channel interference can be kept at a very low level provided that the intermediate frequency is not lower than 400 kc/s.

Parasitic Oscillation

The commonest troubles encountered in converters of this type are parasitic oscillation and pulling. Parasitic oscillation often occurs in the oscillator circuit and then the remedies described in pages 82-84 will usually effect a cure. It can occur in the hexode or heptode section of the valve, however, and the remedy is then to insert a resistance of about 50-100 ohms in the control grid lead. The remarks on pages 157-158 about the amplitude of the injected oscillator voltage should be borne in mind, however, for this is just as important in a converter as in a complete short-wave receiver.

Pulling is usually most evident when the signal and oscillator circuits are separately tuned and, as its name implies, the setting of the oscillator control becomes dependent on the setting of the other. With such interaction between the controls, tuning is difficult. It is not always possible completely to eliminate it; in fact, it is theoretically possible to avoid it only when the coupling to the oscillator is purely electronic and this is never completely achieved in practice.

In the author's experience there should be no noticeable pulling with the triode-hexode frequency-changer on wavelengths above some 10 metres and only slight traces down to 5 metres. With heptodes and octodes rather more pulling is likely to be experienced below 20 metres, and it is often serious on the ultra-short waveband.

Any pulling more serious than that indicated must be taken to mean that unwanted couplings exist between the signal and oscillator circuits external to the valve. Every endeavour should be taken to eliminate them, therefore, by careful attention to detail in screening, wiring and decoupling.

When all tuning controls are ganged the effects of pulling are

WIRELESS SERVICING MANUAL

not so evident, but they make the operations of ganging difficult to perform. Sometimes, however, pulling makes tuning troublesome by causing a curious effect. As the control is rotated across a station the strength of the signal increases in the usual way, but instead of reaching a maximum and gradually decreasing afterwards, a point is found beyond which the slightest further movement causes the strength to drop enormously. If then the control be turned back, the signal does not attain the same volume at the previous maximum but at a setting appreciably different.

The interaction between the tuned circuits is responsible because under certain conditions a very small change in the tuning of a signal-frequency circuit suddenly causes a much larger change in the tuning of the oscillator circuit. The effect is particularly serious where A.V.C. is used, because the A.V.C. voltage usually has a slight effect on the oscillator frequency. This should be too small to be noticeable, even at the high frequencies used in short-wave reception, but it will not be in the circumstances indicated.

Both pulling and oscillator stability become very important on short waves and if there is any serious degree of interaction between the tuned circuits or if the oscillator frequency wanders with changes in the voltages applied to the valves, A.V.C. is worse than useless. In the case of the oscillator some drift in frequency is to be expected for half-an-hour or so after the set is switched on ; in fact, until the valves have attained their normal operating temperature. Other factors affecting frequency-stability are dealt with on page 160.

Microphonic Howling

The most commonly encountered difficulty in short-wave reception, and particularly in ultra-short-wave reception is, howling due to microphony. This is dealt with on page 131 for the case of receivers covering only the medium and long wavebands, but it is much more common and more severe in sets or converters operating on short waves. It is often more troublesome in converters than in complete sets in which the relative positions of the loudspeaker and the S.W. equipment are fixed by the design. Although valves, coils, and even wiring can be responsible, the trouble is usually due to vibration of the plates of the variable condenser. Experience shows that it is imperative to use a flexible mounting for the condenser ; the degree of freedom necessary in any case, however, depends largely upon the rigidity of the vanes.

SHORT-WAVE CONVERTERS

It is not always essential that the condenser be mounted flexibly on the chassis, for when it is not the chassis itself can be mounted on blocks of sponge rubber. Owing to the greater weight of the chassis, however, it is difficult to obtain sufficient flexibility in this way to meet the requirements of short-wave reception. Probably the best course is to mount the condenser flexibly on the chassis and then to stand the chassis on sponge rubber, thus combining the advantages of both methods. It should be noted that individual isolation of the condenser is not always needed. Sometimes the condenser with tuning coils, waveband switching, and the early valves, are mounted on a sub-chassis which is joined to the main chassis by an absorbent mounting. As this sub-chassis is quite light, this scheme is usually successful.

Ultra-Short Waves

On ultra-short waves, below about 10 metres and extending into the television band, microphony becomes very serious, and extreme precautions are necessary for its avoidance. This is because at the higher frequencies involved a given movement of the condenser vanes causes a much larger change of frequency.

The way in which microphony increases with frequency is not difficult to understand. Suppose that the I.F. amplifier has a resonance curve like that of Fig. 90, this is an idealised curve with a flat top 10 kc/s in breadth. Now if the intermediate frequency is 465 kc/s and the set is tuned to receive a station on 1,000 kc/s, the oscillator is operating at 1,465 kc/s. Suppose, further, that acoustic feed-back causes the plates of the oscillator condenser to vibrate by an amount such that the oscillator frequency changes by $\pm 1,000$ c/s. The oscillator frequency then varies periodically between 1,464 kc/s and 1,466 kc/s, and the intermediate frequency varies between 464 kc/s and 466 kc/s. The intermediate frequency thus varies by ± 1 kc—the same amount as the oscillator—about the mean value.

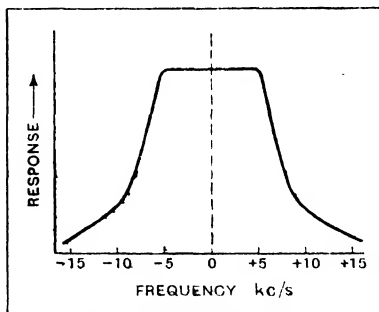

Fig. 90 : An idealised resonance curve of a superheterodyne I.F. amplifier

WIRELESS SERVICING MANUAL

Owing to the flat-topped resonance curve of Fig. 90, however, this causes little harm, for ignoring small effects due to the sidebands if the carrier is modulated, there is no variation in the detector input. Suppose, however, that we now tune in a station on 10 Mc/s (30 metres). The oscillator frequency will now be 10,465 kc/s, but the variation due to microphony will not be ± 1 kc/s, for the amount of vibration of the condenser plates will be the same as before. Assuming the same L/C ratio in the tuned circuit the percentage change of frequency will be the same; that is, the frequency will vary by 1 part in 1,465, or $10,465/1,465 = 7.15$ kc/s. The intermediate frequency will consequently sweep between 457.85 kc/s and 472.15 kc/s, and it will no longer remain within the limits of the flat top of the resonance curve, but will sweep over the sloping sides, causing the detector input to vary. This naturally varies the sound output from the speaker and hence the vibration of the condenser vanes.

Higher Frequency Drawbacks

At higher frequencies, matters are still worse. Thus, at 41.5 Mc/s (7.23 metres) the frequency used for the sound accompaniment to television, the oscillator frequency would be 41.965 Mc/s, and on the same basis as above the change in intermediate frequency would be no less than ± 28.74 kc/s.

In practice, of course, it is very doubtful whether the changes are actually as great as this, for there are various modifying factors which have been ignored for simplicity. Nevertheless, the broad fact emerges that the less selective the I.F. amplifier, the greater the freedom from feed-back effects. A certain degree of selectivity is needed for the avoidance of interference and one cannot avoid microphony with safety by adopting this means on the ordinary short wavebands.

It is, however, legitimate to do so on the ultra-short wavelengths, for here interference is not yet a problem, and the use of a wide band-width for the I.F. amplifier not only renders microphony of little importance but it enables really high-quality reproduction to be obtained, since the highest musical frequencies can be fully reproduced. For ultra-short-wave working, a special superheterodyne is thus needed for the best results, a band-width of 20-30 kc/s with an intermediate frequency of 5 Mc/s is satisfactory. A converter can be used with an ordinary broadcast set, but the average set is too selective to prevent some difficulty being experienced from microphony.

CHAPTER 19

THE LOUD SPEAKER

THE defects which can develop in a moving-coil loud speaker are quite numerous, and are often very difficult to trace. Fortunately, however, they occur comparatively rarely, for the modern speaker is a fairly robust instrument and will withstand a lot of misuse. Defects in the field winding, such as an open-circuit or short-circuit, are easily located by a resistance test and need not be further considered. The faults which are most difficult to trace occur in the cone and its suspension system, and they produce distortion which it is easy to mistake for that introduced by an overloaded valve.

One of the commonest faults is a dirty air-gap between the poles of the magnet. It must be remembered that the magnet is powerful, and in the course of time it collects stray iron filings and these accumulate in the gap, together with dust and dirt, and foul the moving-coil. Its movement is consequently impeded in an irregular manner and the quality of reproduction is affected, becoming "fuzzy" on loud passages. This trouble is rather more likely to occur with a permanent magnet speaker than with an energized model, since its magnetism is always present, whereas the full magnetism of the latter is only produced when the field is energized.

In order to clean the gap properly it is necessary to remove the cone and moving-coil assembly and to wipe the gap thoroughly with a piece of cloth wrapped round a thin sliver of wood. Thorough wiping is essential if all particles are to be removed, for the particles of magnetic materials have naturally a strong tendency to stick to the faces of the magnet, and it is a great help to smear the cloth with a little vaseline.

On replacing the cone assembly, it is necessary carefully to centre the coil in the gap so that it moves freely without coming into contact with the pole pieces. Centring is often needed even when the cone has not been removed, too, for the continual vibration to which a speaker is subject may in time loosen the centring screw or, more often, strain the spider.

When the air-gap is fairly wide, centring is quite easy and is best done by trial and error. A typical arrangement is shown in Fig. 91; the centring screw should be slackened and the coil allowed to take up its own position. Then tighten the screw with the fingers so that it only just holds the spider. If the cone is now moved gently in and out by grasping it at

WIRELESS SERVICING MANUAL

diametrically opposite points with the fingers, it is easy to tell whether it touches the magnet or not. If it does, determine which side it is touching and move the spider appropriately. When the central position has been found, the centring screw must be properly tightened.

It is very important that all screws and nuts on a loud speaker be thoroughly tight, otherwise they will rattle, usually on certain musical notes only. A similar effect, which varies from a rattle to a buzz, can be caused by an imperfect seam in a cone, or a poor joint of cone to spider, cone to moving coil, or cone to surround. In many cases such joints are made with overlapping paper cemented together; if the cement cracks the two edges will rattle against one another and cause distortion at certain frequencies and particularly at large volume. The remedy, of course, is to cement the surfaces together again, and this is readily done with a cement consisting of celluloid dissolved in amyl acetate.

Faults of this nature are not a common occurrence with the ordinary loud speaker and under normal conditions of use; they are most likely to occur when the amplifier has a large output stage. They are, however, very probable if the speaker be used for any length of time with an amplifier which is motor-boating, for the large amplitudes developed are a severe strain upon the cone suspension and the centring device.

There are, of course, many other defects which may be present in a loud speaker, such as a poor frequency response, or a non-linear motion of the cone. These, however, are by no means easy to remedy and are, in fact, often defects in the original design and not faults which have developed with use. There is consequently little which can be done to remedy them and the only certain method of deciding whether any fault is peculiar to a particular specimen, or whether it is common to all models of that type, is a comparative test of two specimens under the same conditions.

Even with the best speaker, the performance will not be good unless it is correctly used and the baffle or cabinet is a very important item, as is also the matching of the speaker to the output valve. From most points of view a flat baffle is the best and it should be constructed from rigid material if it is not itself to introduce resonances. Good results can be secured with a baffle 3 ft. square of 7-ply wood provided that it is braced and rigidly mounted. Theoretically, of course, a much larger baffle is necessary for the full reproduction of the lowest frequencies, but this is rarely practicable. It is sometimes

THE LOUD SPEAKER

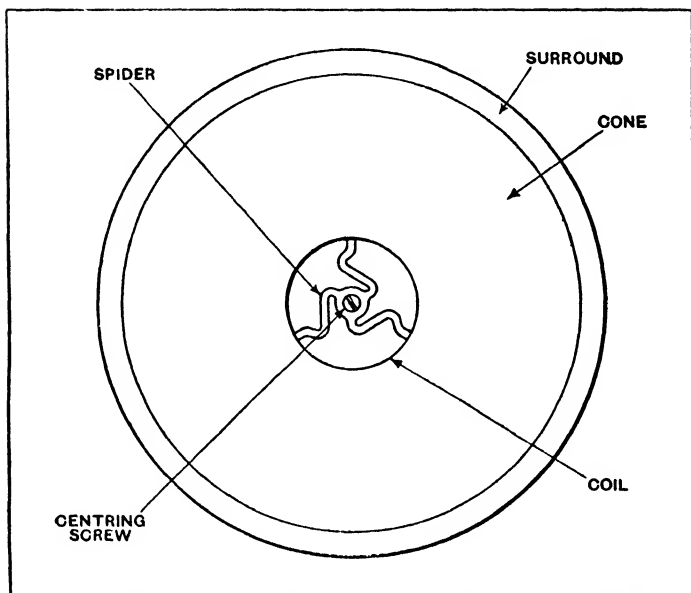

Fig. 91 : The moving-coil can readily be centred by slacking off the centring screw and moving the spider so that the coil can move freely

possible, however, to build a loud speaker into a wall between two rooms so that each room is served by one side only of the cone, and this constitutes an ideal baffle.

Cabinet Resonance

In most practical cases, however, the loud speaker must be used in a cabinet and great care must be taken to avoid resonances. These occur at low frequencies, and while they give a false bass which is not always objectionable on music, they often make the reproduction of speech unnatural and intolerably "boomy". The golden rules for the avoidance of box resonance are to use as wide and shallow a cabinet as possible and to construct it rigidly of heavy wood. In practice, however, it more often happens that one is confronted with a cabinet of light wood, sometimes ply-wood, having a depth nearly equal to the width and the problem is so to arrange matters that box resonance does not occur.

WIRELESS SERVICING MANUAL

This is naturally much more difficult, but it is a problem which often arises. In many cases no complete solution is possible, but some improvement can usually be made. If space permits, the best course is probably to line the cabinet with slag wool, but this is rarely possible when the receiver is contained in the same cabinet as the speaker, and the best course in these circumstances is usually to line the cabinet with some acoustically dead material, such as Celotex board.

If this cannot be done, or proves ineffective, it is advisable to relieve matters by cutting holes in the cabinet at appropriate points. As much of the bottom as possible should be removed, assuming that the cabinet has legs, so that the bottom is spaced from the floor, and if this proves insufficient holes can be cut in the sides and covered with gauze to prevent the entry of dust.

Such holes will naturally reduce the baffle area and so tend to reduce the bass response, but they are very effective in eliminating box-resonance and the net result is usually a considerable improvement in the quality of reproduction.

Even the best speaker and baffle will not give good results, however, if the matching to the output stage of the receiver is incorrect. Most valve makers publish a figure for the optimum load impedance required by an output valve, and figures for current types also appear in the *Wireless World* Valve Data Supplement. The speech-coil impedance of the loud speaker can be obtained from its makers and the transformer ratio is then easily calculated from the formula, $\text{ratio} = \sqrt{Z_L/Z_s}$, where Z_L is the load impedance required by the output stage and Z_s is the impedance of the speech coil. When Z_L is greater than Z_s , as it is in practically all cases, the ratio is a step-down from primary to secondary.

Load Impedance

In general, when two output valves are used in parallel in the output stage the load impedance required is one-half of that needed by one valve, while when they are in push-pull the load impedance should be twice the figure for one valve. It should be understood that the valve maker's figures for load impedance apply only when the valves are used under the rated conditions. Set designers often choose different operating conditions, particularly when a push-pull output stage is used, and the load impedance then required may differ from the valve makers' figure.

With triode output valves, the matching is not very critical and appreciable departures from the optimum conditions can

THE LOUD SPEAKER

be made without seriously affecting the performance. The use of a transformer of higher ratio than the optimum leads to some drop in sensitivity but may actually improve quality slightly. A lower ratio than the optimum, however, may give increased sensitivity but is likely to affect the quality seriously. With pentode output valves, however, Class "AB" and Class "B" types, very little mismatching can be tolerated from the point of view of quality, and serious distortion may occur if the load on the output stage is not kept quite close to the optimum figure.

The output transformer is important apart from its ratio, and if it is not to introduce distortion it must have a high primary inductance and a very low leakage inductance. These requirements are mutually opposing and a good transformer will consequently have a large core, many turns, and the primary and secondary windings will be in many interleaved sections. Except with small output stages, a large core is necessary to avoid amplitude distortion due to saturation of the core at low frequencies.

The important factor is the ratio of the primary reactance at the lowest frequency to the effective circuit resistance, which is the output resistance of the amplifier in parallel with the load resistance required by the amplifier.

For the best results with an output of 4 watts, the core section should not be less than 1.5 sq. in. using Stalloy laminations. This applies when the load impedance is 10,000 ohms, the amplifier output resistance is 1,500 ohms and the primary inductance 70 H. The use of a lower load impedance would permit a smaller core to be used or larger power to be handled by the same transformer.

When a transformer is to be selected for a large amplifier, therefore, care must be taken to obtain one with adequate inductance and core if the bass is to be properly reproduced without distortion, and of low leakage inductance if the higher frequencies are to be fully reproduced. On account of the high A.C. resistance of pentodes, the output transformer would have to be impossibly large if it were not for the fact that negative feed-back can be used to reduce the output resistance to any desired figure.

The High-Note Tweeter

With high quality equipment the moving-coil speaker is sometimes supplemented by a high-note tweeter. In general, the moving-coil speaker fails to maintain its output at the highest audible frequencies and an additional speaker, specially

WIRELESS SERVICING MANUAL

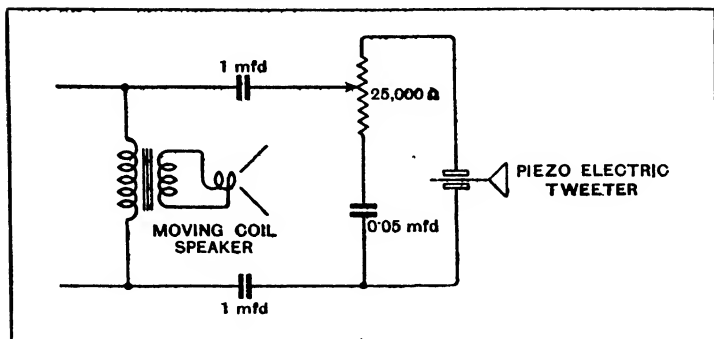

Fig. 92 : The method of connecting a piezo-electric tweeter and moving-coil speaker is shown here

designed to deal with these frequencies only, enables a considerable improvement in reproduction to be obtained. The use of a tweeter is, of course, only justified for high quality local reception, for the avoidance of interference necessitates the suppression of the highest frequencies when receiving other stations.

The piezo-electric principle is commonly employed for tweeters and the best method of connection is usually the one shown in Fig. 92. The potentiometer is included in order that the correct balance between the two speakers may be secured, for moving-coil types differ widely in their sensitivity. It is important to note that if the correct effect is to be secured the tweeter must be mounted close to the moving-coil speaker, and it is usually best just above it.

CHAPTER 20

EXTENSION LOUD SPEAKERS

TO everyone there comes at some time the problem of fitting one or more additional loud speakers to a receiver. Many modern receivers are, of course, arranged by the makers so that this is easy, and there is then nothing to do but follow their instructions. In the general case, however, it is necessary to exercise some care if satisfactory results are to be secured.

The correct solution to the problems involved may turn out to cost more than one at first expects, so that it is best to tackle the question from two different angles. One way is to consider the matter from the scientific point of view and find the arrangement which, regardless of cost, will give the best results. This will often be one the cost of which is only justifiable in a high quality permanent installation. The second method is to adopt a more commercial attitude and find the cheapest system which will enable reasonably good results to be obtained.

Considering this second method first, the usual procedure is to obtain an additional permanent magnet type speaker complete with output transformer and to connect the primary of this transformer in parallel with that of the existing output transformer. Since the extension leads will then usually be joined to positive H.T., it is a good plan to modify the system by inserting a 2 μ F condenser in series with each lead at the receiver end. An accidental short-circuit to earth from any point on the extension line will not then cause damage through short-circuiting the H.T. supply.

It is easy to see that the drawback of this simple scheme is that the operating conditions of the output valve are upset, for its load impedance is lowered. If the valve normally works into the correct impedance its load will be too low when both speakers are in use, and amplitude distortion will be increased. Furthermore, the extra speaker robs the other of power, so that the volume control must be turned up to maintain normal volume, and there is again the likelihood of an increase in distortion.

It often happens, however, that a much lower level of volume is required from the extra speaker, since in many cases it is used in a smaller room than the main one. It is then possible to improve matters considerably by deliberately mismatching the extra speaker. If the output valve requires a load impedance of 5,000 ohms, for instance, which is provided by the main

WIRELESS SERVICING MANUAL

speaker, then instead of using an extension speaker having a transformer to give this same value of load, provide it with one giving an impedance of, say, 20,000 ohms.

Advantage of Mismatching

Instead of the load on the valve decreasing from 5,000 ohms to 2,500 ohms, it will then only fall to $5,000 \times 20,000/25,000 = 4,000$ ohms, and the operating conditions will be much less affected. Furthermore, instead of the power being divided equally between the speakers, it will divide in inverse proportion to the transformer primary impedances. Thus, in the above case, the main speaker will take four-fifths of the power and the extra speaker one-fifth; the difference in volume between the two will consequently be 6 db. Ignoring any loss due to the change in load impedance on the output stage, the volume of the main speaker will drop by 1 db. only, instead of 3 db., when the extra loud speaker is connected. The volume from the extra speaker will be 3 db. below that given by equality of transformer primary impedances.

When this course is adopted it is possible to include a make-and-break switch in series with one of the extension leads to permit the extra speaker to be switched on and off at will, and the performance of the main speaker is hardly affected. Where a number of extra speakers is required, however, this arrangement is hardly practicable and it becomes necessary to adopt a more scientifically-designed arrangement.

To take the most general case, let there be a total of n speakers and let it be required to feed each with the same amount of power. If all speakers are identical their speech coils can all be in parallel, the extension leads then being in the output transformer secondary circuit. The ratio of this transformer is equal to $\sqrt{nZ_L/Z_s}$ when Z_L is the optimum load required by the valve and Z_s is the impedance of the speech coil of one speaker.

When the impedance connected to any one line is of the order of 50–500 ohms, this arrangement is satisfactory for lines of up to some 200 ft. By the impedance connected to the line is meant Z_s/n_1 where n_1 is the number of speakers connected to that line. Thus with $Z_s = 100$ ohms, it is possible to feed two speakers through one line quite safely, provided that heavy gauge conductors are used, but if there are more than two speakers extra lines should be used. When the line length is shorter, however, a lower impedance termination is possible and it is possible to use 30 ft. or so with Z_s no more than 15 ohms.

EXTENSION LOUD SPEAKERS

Secondary Extensions Inadvisable

Many speakers have lower impedances than this, however, and 2.5 ohms is a common value. It is then inadvisable to run extension leads in the secondary circuits and each speaker should be provided with its own transformer.

This must be done when the speakers have different values of Z_s and the ratio of each transformer should be $\sqrt{nZ_L/Z_s}$, Z_s being the speech coil impedance of the speaker under consideration. It will be seen that this gives the same ratio as before when n , Z_L and Z_s are the same. Generally, however, the transformers will not be the same.

With only a single transformer, the primary reactance should be twice Z_L at the lowest important frequency. When each speaker has its own transformer, however, the primary reactance of each should be equal to $2nZ_L$; that is, the primary inductance in the second case should be n times that in the first. It is not always possible to adhere to this rule.

The difficulty in fitting each speaker with its own transformer is that the lines cannot be very long before capacity effects upset the operation by removing most of the upper musical frequencies. The speech-coil impedance of the average speaker is too low to permit a long line in the transformer secondary circuit on account of the resistance and inductance of the wires, while the load impedance of the average output stage is too high to permit a long line being used in the primary of the output transformer on account of the capacity.

When Long Lines are Used

In cases where very long lines must be used, therefore, it becomes necessary to take the impedance of the line into account. Transmission line theory becomes quite complex in all but its simplest branches, and it will not be treated here. As applied to extension speakers, however, it involves the use of a transformer at each end of the line, one at the receiver to match the output stage to the line and another at the speaker to match the line to the speaker.

Where a number of speakers is used and matched correctly, the output of the amplifier is divided equally between the speakers. If the output is only sufficient for one speaker, therefore, it is necessary to redesign the output stage so that it will supply n times the power.

Not only is an extra loud speaker a common addition to a receiver, but either a microphone or a gramophone pick-up is often required. Most sets are arranged for the connection of a

WIRELESS SERVICING MANUAL

pick-up and it is necessary only to choose a model of adequate sensitivity for the particular receiver with which it is to be used and to connect it to the terminals fitted. Provided that the connecting leads are screened, trouble is rarely experienced, for the leads do not usually exceed about three feet in length.

It occasionally happens, however, that it is desired to operate the pick-up at a considerable distance from the receiver or amplifier and serious difficulties are then likely to be found. Pick-ups are normally designed for working into high impedances, 0.1–0.5 megohm, with the result that the capacity between any considerable length of connecting lead seriously affects the performance. The capacity is, in fact, very considerable, since screened leads are essential for the avoidance of hum pick-up.

With the conventional pick-up, there is only one remedy and this is to connect a step-down transformer between the pick-up and the leads connecting it to the receiver. With a suitable transformer, the effect on quality is negligible, but there is a loss in efficiency unless a step-up transformer is also used to connect the line to the receiver.

A better course is to employ a low-impedance pick-up which can be connected directly to the line; only the step-up transformer from line to amplifier is then needed. Pick-ups wound for an impedance of 600 ohms, however, are not generally obtainable, probably because a step-up transformer is essential in all circumstances if their efficiency is to compare with that of the more common types.

Microphones, too, bring their own problems and with nearly all types a transformer is needed having a step-up ratio between the microphone and receiver. The ratio is readily calculated and is equal to $\sqrt{Z_s/Z_p}$ where Z_s is the value of the resistance, usually a volume control, shunting the transformer secondary, and Z_p is the impedance of the microphone. With carbon type microphones the impedance is practically the same as the D.C. resistance at the normal operating voltage.

Unsatisfactory results are often secured when a microphone is connected to the pick-up terminals of an ordinary receiver, because the amplification is not always sufficient. The output of a carbon microphone is only about 0.1 volt and most modern receivers require an input of the order of 1 volt at the pick-up terminals. Other types of microphone give smaller outputs and in general the better the microphone from the quality viewpoint the smaller its output. It is, therefore, often necessary to connect an amplifier between the microphone and the pick-up terminals of the receiver if adequate volume is to be secured.

CHAPTER 21

THE AERIAL-EARTH SYSTEM

SINCE amplification was difficult to obtain in the early days of wireless, great attention was then paid to the aerial and earth system, for improving its efficiency was the most practicable method of increasing the range of reception and signal strength generally. With the common use of modern highly sensitive receivers, however, it is now all too often neglected ; the listener then pays the price not necessarily of an absence of signals, but of a poor signal-noise ratio.

Even with a complete absence of local interference there is a limit to the amplification which can usefully be employed. As explained on page 81 the receiver itself inevitably introduces a certain amount of noise and it is essential for the signal delivered to the set by the aerial to be stronger than this noise if satisfactory reception is to be secured. The noise level is fixed for any given receiver and there is very little which can be done to reduce it ; the level, however, depends on the type of set and, comparing types of equal sensitivity, will normally be greater in a superheterodyne in which the first valve is a frequency-changer than in one which includes an R.F. amplifier. A set of the latter kind is, in fact, the equal of the straight set as regards noise.

The actual noise level is not of much importance, however, if we can obtain an adequate signal-noise ratio. Obviously, it does not matter whether there is $1 \mu\text{V}$ of noise voltage on the grid of the first valve or $100 \mu\text{V}$, provided that when the receiver is delivering normal volume from a signal the noise is inaudible. It is always the signal-noise ratio which is important ; the signal level depends on the power and distance of the transmitter and upon the prevailing conditions. It also depends on the aerial system, whereas the noise depends only on the receiver. The signal-noise ratio thus depends on both receiver and aerial.

Suppose, for example, that two receivers A and B have the same sensitivity but noise levels of $1 \mu\text{V}$ and $10 \mu\text{V}$ respectively, then equal signal-noise ratios will be secured with signal inputs of, say, $10 \mu\text{V}$ and $100 \mu\text{V}$, and the noise, although audible, will not be serious. Now if the poorer receiver B is used with a good outdoor aerial noise will, in general, be negligible on the stronger Continental transmissions, for at night many of these provide signals of up to $1,000 \mu\text{V}$. If receiver A is used with

WIRELESS SERVICING MANUAL

a poor aerial, such as a small indoor aerial, however, the same signal may provide no more than one-hundredth the input. Under these particular conditions there will be a signal-noise ratio of 10 : 1 for receiver A and 1,000 : 1 for receiver B ; in other words, the poorer receiver gives ten times the signal-noise ratio.

In practice, of course, the difference is rarely as great as this, but the example emphasises the importance of the aerial. A good receiver will always give a better performance than a bad one when the comparison is made on similar aerials, but it is quite possible for the bad set with a good aerial to be better than a good set with a bad aerial. After all, a receiver can only work on the input with which it is supplied and it is the business of the aerial to supply this input.

Circumstances Governing the Aerial

Now the best type of aerial depends upon circumstances and there are many factors to be taken into account. In cases where local interference is present it will probably be necessary to adopt one of the special lead-in systems described in Chapter 9, and certain of these are now obtainable in a form suitable for all-wave reception. In general, anti-interference aerials are less efficient than ordinary types, so that their use leads to a lower signal-set noise ratio. The local interference, however, will be so much greater than the set noise in all cases where such an aerial system is used that the latter is negligible in comparison. There is no doubt whatever that when local interference is troublesome the use of a suitable type of anti-interference aerial will effect a great improvement, provided always that the aerial proper, as distinct from the lead-in, can be erected outside the field of interference. If this cannot be done, then the interference will still be present.

Importance of the Earth

In this connection it should not be forgotten that the earth may be as important as the aerial. Signals and interference can be picked up by the lead from the receiver to earth and *by the ground itself from the earth to a point below the aerial.* Little in the way of signals is picked up by this portion because of its low effective height, which reaches zero in the case of the ground. Severe interference may be picked up, however, sometimes even more than by the aerial lead-in. The interference is often severely local and the earth lead often passes through the most intense part of the field ; moreover, there

THE AERIAL-EARTH SYSTEM

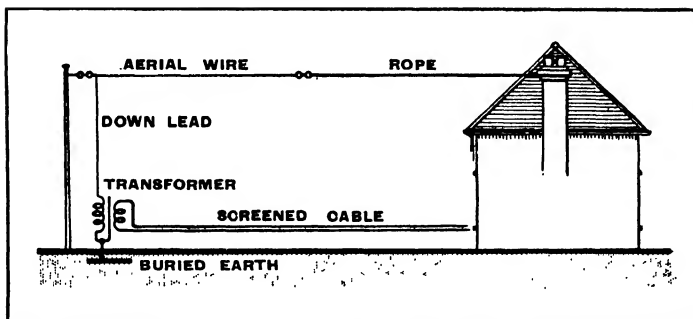

Fig. 93 : This sketch shows one method of erecting an aerial at a distance from a house in order to keep it out of the interference field

may be interference currents circulating in the ground. It must never be forgotten that the complete aerial circuit comprises the horizontal span of the aerial, the lead-in, the primary circuit of the receiver, the earth lead, the conductors (water-pipes, soil, etc.) from the point of connection of the earth lead to the area beneath the aerial, and the space between the horizontal span of the aerial and the ground beneath. At any point within this circuit interference can be picked up and there is little to be gained by screening the down-lead if the earthy path from receiver to the under-aerial ground passes through the interference zone. Disappointment with anti-interference aerials, when care has been taken to erect the aerial itself outside the field of interference, is most probably due to neglect of this point.

Theoretically, it is only possible to secure complete freedom from interference when the entire aerial-earth system is removed from the field of interference. This is not always as difficult to arrange as it sounds, and the scheme depicted in Fig. 93 can often be adopted. It will be seen that the aerial is erected well away from the house, and the down-lead and *earth* arranged at the end remote from the house. In normal circumstances this will give the minimum of interference, for the whole aerial-earth system is as far as possible from the house in which the interference is presumed to originate.

Since it is somewhat inconvenient to keep one's receiver at the bottom of the garden, it is necessary to take the signals picked up by the aerial to the receiver without interference being picked up en route. This is done by means of the step-down transformer and screened low-impedance cable. This

WIRELESS SERVICING MANUAL

latter can usually be readily disposed inconspicuously by burying it or cleating it to the garden fence.

The difficulties are greater, of course, where no garden is available, but even then they are not always insuperable. In the case of a modern building such as a block of offices or flats, the aerial must usually be erected on the flat roof and there is usually very severe interference generated within the building itself. If the receiver is on one of the lower stories the conventional screened down-lead and earth may prove satisfactory, but is unlikely to be so when the receiver is used on an upper floor, for quite a large portion of the building is then acting as an earth lead. The best results are then likely to be secured by using a counterpoise earth as shown in Fig. 94. The aerial should be erected as high as possible and a counterpoise, consisting of several parallel wires about a foot apart and connected at one end but otherwise insulated, erected beneath it and used as the local earth. The counterpoise can be about six feet above the roof. The importance of height

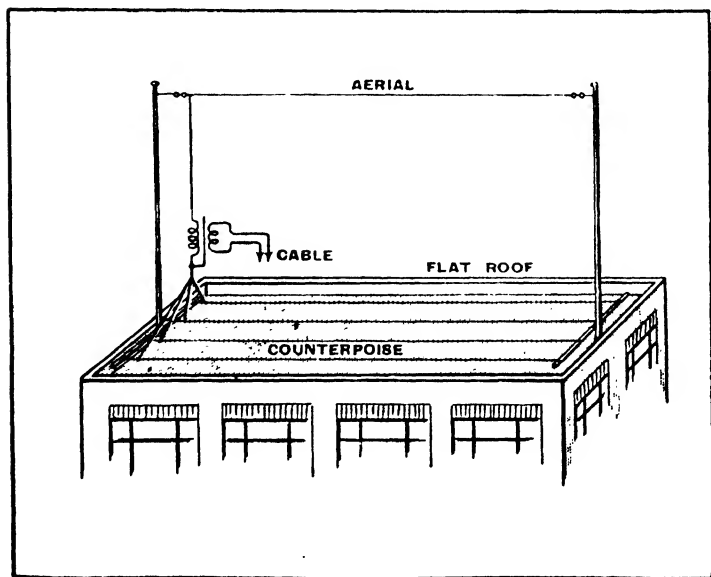

Fig. 94 : On a large building, a counterpoise may prove superior to an earth connection

THE AERIAL-EARTH SYSTEM

for the aerial will be realised when it is remembered that the effective height will not exceed the distance between aerial and counterpoise.

Arrangements such as these, however, are necessary only when local interference is present. In the domestic areas of rural and suburban districts local interference is probably negligible in most cases, and efficiency is the chief factor to be considered in the design of an aerial, and in the attainment of efficiency height is the most important factor. For general reception on all wavelengths experience shows that the ordinary inverted-L aerial is the best. It is very difficult to improve on this type for medium and long wave reception and in most cases it is the best for the short waves also. An exception occurs when reception is required on a particular wavelength or a narrow band of wavelengths only, for then some form of resonant aerial can be used with advantage.

The physical dimensions of resonant aerials are proportional to the wavelength and it is consequently only possible to erect types for the shorter wavelengths in the space available in the normal garden. Moreover, a resonant aerial must be joined to the receiver properly; with most types a simple lead-in wire is not good enough. It is necessary to use a properly terminated transmission line, which is more usually termed a feeder, and which if arranged correctly does not itself pick up signals. Such aerial systems are consequently also anti-interference aerials and a correctly arranged resonant aerial and feeder will give as much freedom from local interference as the usual anti-interference types. It will do this with high efficiency as long as it is only used for reception on wavelengths close to the resonant value; at other wavelengths the efficiency falls off, and the immunity from local interference is also reduced because with the change in the aerial impedance the feeder is no longer correctly terminated.

Use of a Resonant Aerial

In general, a resonant aerial is to be recommended when reception in a particular narrow band is desired. Anyone who is specially interested in 10-metre or 20-metre amateur reception, for instance, would be well advised to erect an aerial resonant to one of these wavelengths. Again, for some special reason, the best possible reception of some particular station, such as 2XAD, might be required, and here also an aerial resonant to this wavelength would be advisable. In this connection it should be pointed out that many resonant aerials

WIRELESS SERVICING MANUAL

are directional and should consequently be erected so that best reception is obtained from the desired stations. In working out the direction it is useless to calculate the direction from an ordinary atlas based on Mercator's Projection, as any rate for distances exceeding a few hundred miles. A globe must be used or else a map with a Great Circle Projection.

The simplest form of resonant aerial is a wire having a length which is definitely related to wavelength. The commonest are the $\lambda/2$ and $\lambda/4$ aerials ($\lambda =$ wavelength in metres); the $\lambda/4$ aerial, however, is not such a true resonant aerial, for it depends on the earth for its operation. The current distribution in such aerials is shown in Fig. 95, and is a maximum in the centre for the $\lambda/2$ type and at one end for the $\lambda/4$ type. The impedance of the aerial is lowest when the current is greatest and vice versa, and a half-wave aerial has a centre impedance of about 72 ohms. The end-impedance would ideally be infinite, but in practice is of the order of 2,500 ohms.

The aerial can have the feeder connected at the end or the centre, but the feeder must have the same impedance as the aerial at the point of connection. Now the feeder impedance depends upon the spacing of the two wires of which it consists and upon their diameter, and the values obtainable are severely limited in practice. Where the aerial and feeder impedances are not the same a matching device must be inserted between the two, and this often takes the form of a resonant line which has the property of acting as an impedance transformer.

Special feeder cable with an impedance of 72 ohms is now available, and can be connected directly to the centre of a half-wave aerial as shown in Fig. 96 (a). The feeder should be brought away from the aerial at right angles for a distance

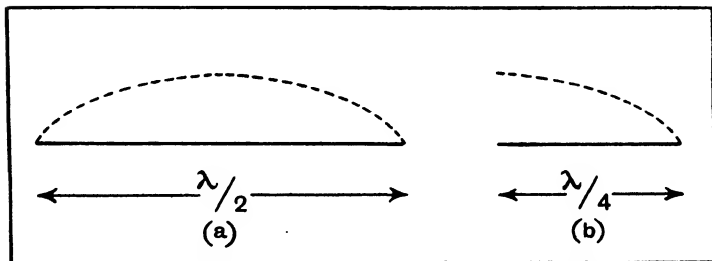

Fig. 95 : The dotted lines show the current distribution in resonant aerials

THE AERIAL-EARTH SYSTEM

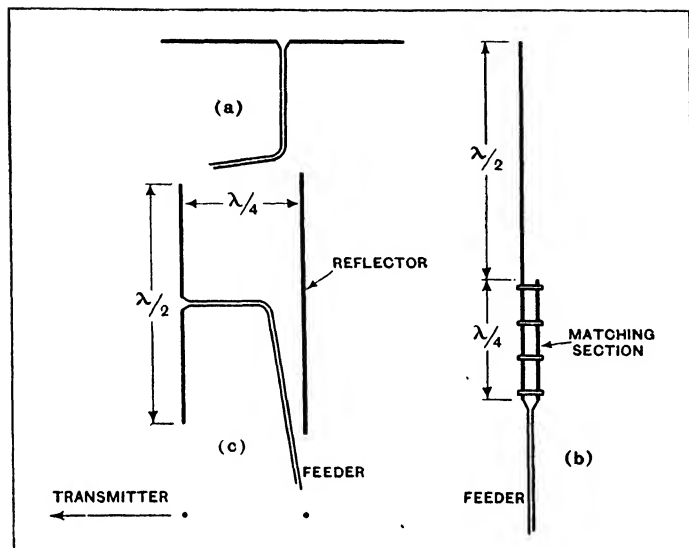

Fig. 96 : The general forms of a horizontal $\lambda/2$ dipole (a), a vertical $\lambda/2$ dipole with $\lambda/4$ matching section (b), and a vertical $\lambda/2$ centre-fed aerial with a reflector (c) are shown here

of at least a quarter-wavelength. This is easy when the aerial is horizontal, but troublesome when it is vertical.

The choice between vertical and horizontal aerials depends on which is used at the transmitter, for the aerials at both ends should be the same. In general, however, this is of little importance in long-distance reception, for the plane of polarisation of the wave-front gets twisted in its passage to the receiving aerial. It is usual, therefore, to adopt a horizontal aerial for ordinary short-wave reception since it is more convenient to erect. For television reception, however, a vertical aerial is necessary, since the transmitting aerials are vertical and the distance is normally short.

Owing to the mechanical difficulty of bringing the feeder out at right-angles from the centre of a vertical aerial, it is usually more convenient to feed it from the end. This necessitates the use of an impedance transforming section for matching the aerial to the feeder. Fortunately such a section is extremely simple to construct for it consists merely of two parallel wires

WIRELESS SERVICING MANUAL

$\lambda/4$ long, as shown in Fig. 96 (b). At the lower end the two wires of the feeder are joined to the two wires of the matching section ; at the upper end one wire is joined to the aerial and the other left free.

In practice, the aerial and matching section are built together and a single length of wire is used for the aerial and one limb of the matching section. The other limb is a length of the same wire spaced from the first by a number of spreaders. The spacing is important and depends on the wire diameter.

A third type of aerial is the centre-fed half-wave aerial with a reflector. This type of aerial gives increased efficiency and somewhat less pick-up of interference on account of its improved directional properties. It consists simply of a $\lambda/2$ aerial centre-fed as in Fig. 96 (c) but mounted vertically. Behind it is mounted another insulated wire of length $\lambda/2$ and spaced from the aerial by $\lambda/4$. In this case it is quite easy to bring out the feeder at right-angles to the aerial, for it can be supported by the framework which is needed for holding the reflector. This type of aerial is widely used for television reception.

The actual lengths of resonant aerials are always slightly shorter than the nominal lengths by which the types are known, for the diameter of the conductor and the method of supporting it affect the resonance frequency. The length of a $\lambda/2$ aerial is thus not exactly one-half wavelength, but must be about 0.94 $\lambda/2$. Full details regarding the calculation of aerial lengths and feeders are given in Appendix I.

It is worthy of note that resonant aerials of the $\lambda/2$ type do not depend upon earth to complete the circuit but are complete in themselves. The earlier remarks regarding the importance of the earth in interference elimination thus do not apply to these types. They are actually of an ideal form for the avoidance of local interference, but the aerial itself must naturally be erected outside its field of influence. Resonant aerials should always be erected as high as possible, for not only does the field strength rapidly increase with height at ultra-short wavelengths, but ignition interference from cars rapidly decreases.

CHAPTER 22

AUTOMATIC FREQUENCY CONTROL

QUITE a number of set makers have in the last few years produced receivers which include some form of automatic frequency control, or A.F.C. for short. (It is also sometimes less correctly known as automatic tuning control, or A.T.C.). It is, however, by no means common as yet, and because of its unfamiliarity its adjustment may prove somewhat troublesome and it may even complicate the ordinary processes of fault-finding. It is, therefore, desirable to treat it in rather great detail.

It is first necessary to be perfectly clear about what A.F.C. is and how it functions. The purpose of A.F.C. is to make it impossible for a receiver to be appreciably mistuned from a signal. In the case of a selective broadcast receiver quite a small amount of mistuning has a marked effect upon the quality of reproduction. In spite of this, many people seem incapable of tuning a receiver correctly and habitually leave it mistuned by amounts up to several kilocycles a second.

When A.F.C. is fitted it suffices if the tuning control is set within some 5 kc/s of the frequency of the desired signal. The set then tunes itself to the signal with quite a high degree of accuracy. It is obviously of great value in motor-driven push-button sets and is frequently included in them.

A.F.C. is applied only to the superheterodyne and it functions by varying the oscillator frequency so that the difference between the signal and oscillator frequencies is brought exceedingly close to the intermediate frequency. The signal-frequency circuits are not affected, so that if the tuning is not adjusted close to resonance by the manual control in the first place, the result is to leave the signal-frequency circuits mistuned. As a rule this is not very important because they are usually fairly flatly tuned.

An A.F.C. system consists of two main parts—the frequency-control stage and the discriminator. The former is a circuit arrangement which behaves as a reactance, the value of which depends upon the magnitude and polarity of an applied voltage, while the latter is a device for producing a voltage of value dependent upon the amount of mistuning and polarity dependent upon the direction of mistuning.

The frequency-control stage almost invariably employs a valve so connected that it behaves as a reactance, the value of

WIRELESS SERVICING MANUAL

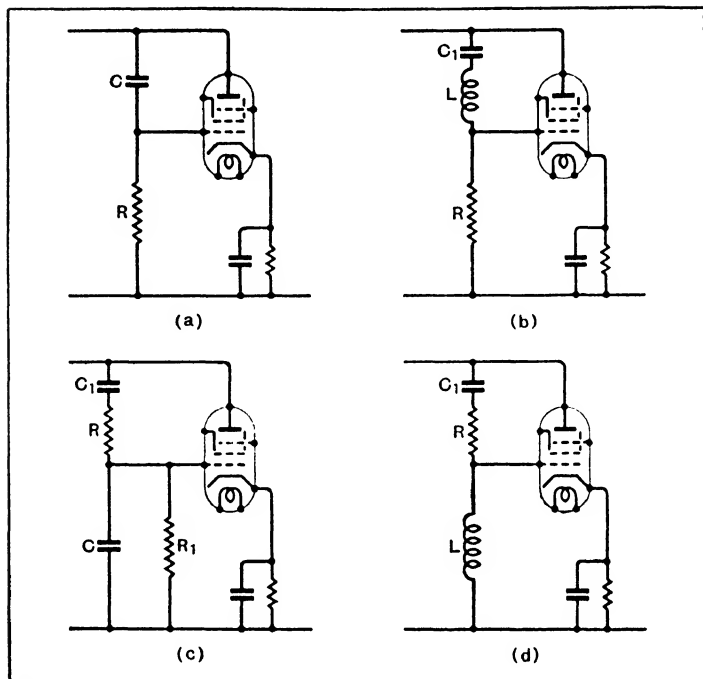

Fig. 97 : Four frequency-control circuits are shown here ; (a) and (d) are equivalent to a variable capacity and (b) and (c) to a variable inductance

which is controllable by varying the grid bias. There are many possible circuits and the chief ones are shown in Fig. 97.

Consider the circuit (a) and assume that the reactance of C at the operating frequency is very largely compared with the resistance R . Then the current through R and C leads the applied voltage by very nearly 90° and the grid voltage leads the applied voltage by the same amount, since it is developed by the passage of this current through R . The anode current of the valve is in phase with the grid voltage, and consequently leads the applied voltage by nearly 90° . A leading current, however, is that drawn by a condenser, consequently the circuit of Fig. 97 (a) behaves as a condenser, the value of which depends on the alternating anode current. This in turn depends

AUTOMATIC FREQUENCY CONTROL

on the mutual conductance of the valve, which can be altered by changing the grid bias. We thus find the circuit to be equivalent to a variable condenser. By similar reasoning, Fig. 97 (b) can be shown to be equivalent to a variable inductance. In this circuit C_1 is merely a blocking condenser and serves only to insulate the grid circuit from the H.T. supply.

An Electronic Inductance

The arrangement (c) is somewhat different. The basic components are R and C ; C_1 is only a blocking condenser and R_1 provides grid circuit continuity. In this case assume that the reactance of C is very small compared with the value of R . Then the current through R and C is nearly in phase with the applied voltage and the grid voltage, developed across C , is 90° lagging on the applied voltage. The anode current is in phase with the grid voltage and is consequently 90° lagging on the applied voltage. The circuit as a whole thus behaves as a variable inductance. By similar reasoning (d) can be shown to be equivalent to a variable condenser.

If the input terminals of any of these circuits are connected across the tuned circuit of the oscillator in the frequency-changer it is clear that the oscillator frequency can be varied by altering the grid bias of the control valve.

It should, of course, be understood that the circuits shown in Fig. 97 are not complete, but merely the basic arrangements. Also, the input impedance is not a pure reactance but always contains a resistive component which damps the oscillator circuit somewhat.

Any of these basic circuits can be used for frequency control, but both (b) and (d) are rarely found in practice. The use of an inductance for the reactive element in the circuit has two disadvantages; it must be screened to restrict its magnetic field and the self-capacity of the coil is liable to modify the action somewhat.

Of the two remaining circuits (c) is the one commonly used. It tends to have a higher input resistance than (a), which is its first point of advantage. Of greater importance, however, is the fact that it behaves as an inductance whereas (a) behaves as a capacity.

The use of a variable inductance effect is advisable because it only necessitates some increase of the oscillator coil inductance to give correct ganging. A variable capacity effect, on the other hand, means that the oscillator circuit capacity must be reduced and this is not always possible.

WIRELESS SERVICING MANUAL

This must be clearly understood if the action of the circuit is to be followed. Take the arrangement (a) acting as a variable capacity. It gives a range of capacity from $C_{\min.}$ to $C_{\max.}$ If the receiver is mistuned so that the oscillator frequency is too high the bias on the control valve is reduced to increase its mutual conductance and so increase its input capacity. On the other hand, if the receiver is mistuned the other way, so that the oscillator frequency is too low, the bias is increased and the mutual conductance and input capacity fall. In both cases the oscillator frequency is brought nearer to its correct value.

Now it is clear that the receiver must be initially ganged with the control valve giving an input capacity of about the mid-point of its range, for otherwise it would not be possible to obtain an equal increase or decrease of capacity for tuning correction. The ganging must be carried out with the control valve adding a capacity of about $\frac{C_{\min.} + C_{\max.}}{2}$ to the circuit.

Now this means that the normal oscillator circuit stray capacity must be reduced by the same amount to enable correct ganging to be secured. The circuit capacity is normally kept as small as possible, however, in order to secure a wide tuning range, and it is consequently often impossible to reduce it further by the requisite amount.

With the inductive input circuit (c) no change of oscillator circuit capacity is needed beyond a small reduction to compensate for the wiring capacity and the anode-cathode capacity of the control valve. This is relatively small and can usually be accomplished without undue difficulty.

The control valve has an inductance varying from $L_{\min.}$ to $L_{\max.}$ with a mean value of $\frac{L_{\min.} + L_{\max.}}{2}$. It is only necessary, therefore, to increase the oscillator inductance so that when it is in parallel with this value it has its original value. If this last is L , the new value L_1 must be $(L_{\min.} + L_{\max.}) / (L_{\min.} + L_{\max.} - 2L)$. This can always be done.

A typical control stage of this type is shown in Fig. 98 connected to a frequency-changer of the triode-hexode type. The oscillator circuit is quite conventional and the control circuit differs from that of Fig. 97 (c) only by the inclusion of the various feed components.

C_1 and C_2 are both blocking condensers and are necessary only to maintain the correct D.C. paths. They are of fairly large capacity, say $0.001 \mu F.$, but are in no way critical. R_2 is

AUTOMATIC FREQUENCY CONTROL

the resistance through which the control voltage is applied and is again not critical as long as it is large compared with the reactance of C_3 . R_4 and C_5 are the usual screen-feed components and R_3 and C_4 are for cathode bias. R_3 is chosen to give a standing bias towards the middle of the valve characteristic. It must not be too small, for the A.F.C. control voltage may be either positive or negative with respect to the earth line. The important components are R_1 and C_3 for they control the value of the input inductance of the stage.

The Discriminator

Now it will be clear that in order to effect the control of the oscillator frequency it is necessary to apply to the control valve a bias voltage the value of which depends upon how much the oscillator frequency differs from the correct value and the polarity of which depends upon whether its frequency is higher or lower than the correct value.

Since the intermediate frequency is dependent on the oscillator frequency this voltage can conveniently be derived from it and it is done by means of a circuit known as the discriminator. There are two main types of circuit—the older is much the simpler to understand, but is much more difficult to adjust. Consequently, it is not often used now. One form of this older circuit is shown in Fig. 99. V_1 is the last I.F.

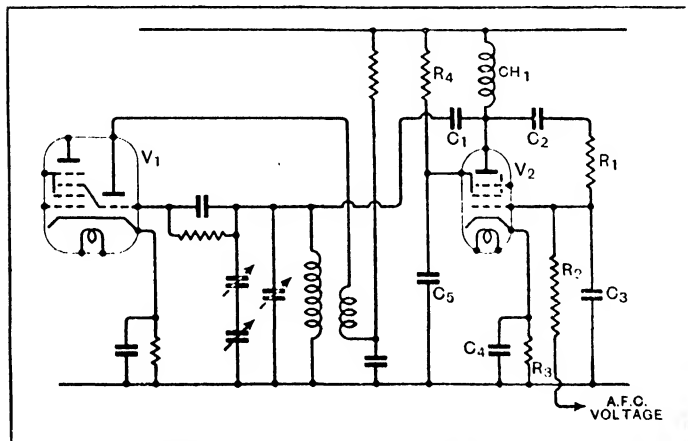

Fig. 98 : This diagram shows a typical arrangement of a frequency-control stage with the oscillator of the frequency-changer

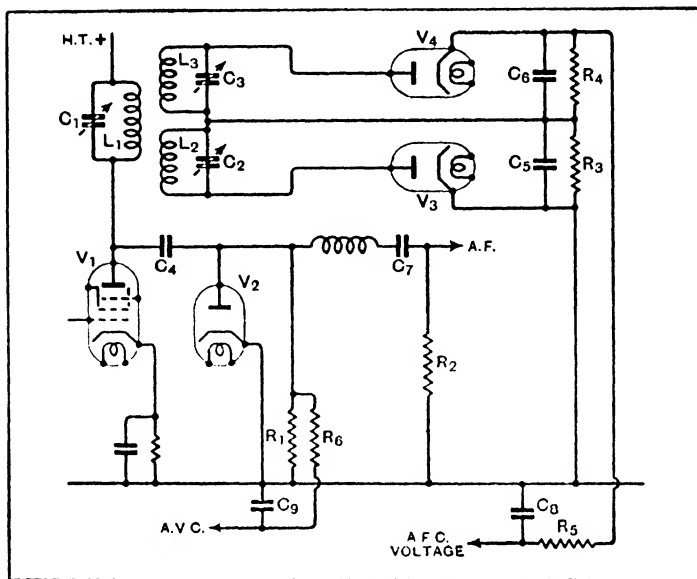

Fig. 99 : An early form of discriminator is shown in this drawing. L2 C2 and L3 C3 are mistuned one on each side of the intermediate frequency

stage and the circuit L_1C_1 is tuned to the desired intermediate frequency. It is fed to the diode V_2 through C_4 ; this diode acts as a detector and A.V.C. source—the A.F. signal being fed out in the usual way through C_7 and the A.V.C. voltage being taken off through the filter $R_6 C_9$.

All this is quite conventional. We now come to the A.F.C. circuits. These consist of the two diodes V_3 and V_4 fed from $L_2 C_2$ and $L_3 C_3$ and with load circuits $R_3 C_5$ and $R_4 C_6$ respectively. L_2 and L_3 are each coupled to L_1 by the same amount so that equal voltages are induced in each.

If these two circuits are tuned to the same frequency the I.F. voltages applied to V_3 and V_4 will always be equal, and if the load circuits are identical the output of each diode will be the same. It will be noted that the cathode of V_3 is joined to earth and the A.F.C. voltage is taken off through $R_5 C_8$ from the cathode of V_4 . The anode ends of the two load circuits are joined together.

The total output is thus the difference between the voltages

AUTOMATIC FREQUENCY CONTROL

across R_3 and R_4 . When they are equal the resultant is zero. Under the conditions given above— $L_2 C_2$ and $L_3 C_3$ tuned to the same frequency—both diodes give equal outputs and the resultant on the A.F.C. line is always zero.

In practice these circuits are not tuned to the same frequency. One is tuned above the intermediate frequency and the other below.

Both circuits must be carefully tuned precisely to the right frequencies. Using the control circuit of Fig. 97 (c) we have seen that if the oscillator is at too high a frequency we need an increase of inductance to correct it and that this necessitates a reduction of grid bias on the control valve.

This in turn means that the A.F.C. voltage must be positive so that the output of V_4 in Fig. 99 must predominate over that of V_3 . Now when the oscillator frequency is too high it means that the intermediate frequency is too high also—in the normal case when the oscillator frequency is higher than that of the signal—consequently, $L_3 C_3$ must be tuned above the intermediate frequency.

What happens is this—when the intermediate frequency is higher than it should be a greater voltage is set up across C_3 than across C_2 because $L_3 C_3$ is nearer resonance with it than is $L_2 C_2$. The output of V_4 exceeds that of V_3 and the A.F.C. voltage is the difference of the two, and positive.

This operates on the control valve to lower the oscillator frequency and reduce the intermediate frequency also. As the intermediate frequency comes nearer to the correct value, the voltage on V_4 decreases and on V_3 increases. Their outputs vary similarly and the difference decreases. An equilibrium condition is soon reached at which the amount of detuning is very small.

There must, of course, always be some degree of mistuning, otherwise no control voltage could appear. If the intermediate frequency is exactly right, the outputs of the two diodes are equal and the A.F.C. voltage is zero. A.F.C. can thus never produce perfect tuning; what it does is to make it impossible for the tuning errors to exceed a very small amount fixed by the designer and which is usually a few hundred cycles at most.

Initial Adjustments

When adjusting a system of this nature it is advisable to follow carefully the instructions appertaining to the particular receiver if they are available. If they are not, the following procedure will usually be satisfactory.

WIRELESS SERVICING MANUAL

Referring to Fig. 99, set C_3 to its minimum capacity and C_2 to its maximum, and short-circuit the discriminator output. This last is conveniently done by short-circuiting C_8 . Then adjust the I.F. circuits, including L_1 C_1 , and the ganging of the signal and oscillator circuits, in the usual way.

When satisfied that the performance of the set without A.F.C. is in every way correct it is time, and then only time, to adjust the A.F.C. circuits. If the frequencies to which the discriminator circuits should be tuned are known the adjustment is not difficult.

Connect a test oscillator to the I.F. amplifier in the same way as for I.F. alignment and a low-range milliammeter in series with R_4 . Set the test oscillator to the higher of the two A.F.C. circuit frequencies and adjust C_3 for maximum output.

Then set the test oscillator to the lower of the two frequencies and adjust C_2 for maximum output with the milliammeter joined in series with R_3 .

These adjustments may not be sufficiently precise for good results, since it is often impossible to set the test oscillator to the desired frequencies with sufficient accuracy. The next step, therefore, is to set the test oscillator to the intermediate frequency and connect a valve voltmeter across C_8 . The valve voltmeter must be capable of responding to a steady potential, so it must not have a condenser input circuit.

If the circuits are correctly adjusted no reading should be found on the voltmeter under these conditions and on detuning the test oscillator the voltage should rise with one polarity for mistuning one way and with the other polarity for mistuning the other. The magnitudes of the voltages for equal amounts of mistuning should be nearly the same.

It will probably be found that with the test oscillator at the intermediate frequency zero output is not obtained. C_2 or C_3 should then be adjusted to bring the output to zero. If equal outputs for equal degrees of mistuning are not then obtained the cause is probably unequal coupling between L_1 and L_2 on the one hand and L_1 and L_3 on the other, or else unequal effective Q values for the tuned circuits.

A.F.C. Circuit Frequencies

If the alignment frequencies for the A.F.C. circuits are unknown suitable ones will have to be found by trial. For a start it is satisfactory to take them as 5 kc/s above and below the intermediate frequency, and to adjust in the manner just described.

AUTOMATIC FREQUENCY CONTROL

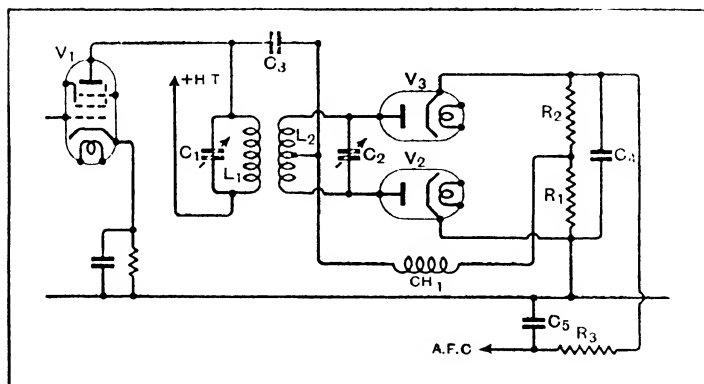

Fig. 100 : With a modern discriminator both tuned circuits are tuned to the intermediate frequency and the action depends on the phase difference of the primary and secondary voltages

If the frequencies related are too near the intermediate frequency the band over which the A.F.C. operates will be too small. In other words, A.F.C. will be capable of correcting for only a small degree of mistuning.

On the other hand, if the frequencies are too far from the intermediate frequency, A.F.C. will operate over too wide a band. If this happens, A.F.C. will prove most unsatisfactory, for it will be liable to be affected by signals on the adjacent channels to the wanted station.

It may then prove impossible to receive a weak signal with a fairly strong one on the next channel, for the set will be liable to tune itself to the stronger. This will be found particularly distressing when there are two fading signals on adjacent channels, for it is quite possible for the set to keep tuning itself from one to the other, keeping in tune with whichever fading makes the stronger for the moment.

The remedy for this state of affairs is to avoid too great an amount of detuning of the A.F.C. circuits and to keep the I.F. selectivity fairly high.

Largely owing to the difficulty of adjustment this particular A.F.C. system is not much used nowadays. A more common arrangement is one similar to that shown in Fig. 100. Here both I.F. circuits are tuned to the intermediate frequency, so that the adjustment is but little different from that of any ordinary amplifier.

WIRELESS SERVICING MANUAL

The circuit shows that there are, as before, two diodes V_2 and V_3 following the last I.F. stage V_1 . The diodes have the load resistances R_1 and R_2 so connected that the outputs oppose one another on the A.F.C. line, which is taken through the filter $R_3 C_5$.

The essential difference between the circuits lies in the method of obtaining the inputs to the diodes. Instead of using separate input circuits tuned to different frequencies, common circuits tuned to the intermediate frequency are adopted.

Phase-Variation System

The action depends upon the phase difference between the currents in L_1 and L_2 . The secondary L_2 is centre-tapped and one-half of the voltage across it is applied to one diode while the other half is applied to the other diode. These two voltages are 180° out of phase with each other relative to the centre point.

The voltage developed across the primary is also applied to the diodes via C_3 connected to the centre tap on the secondary. The total voltage applied to one diode is thus the primary voltage plus one-half the secondary voltage and that applied to the other diode is the primary voltage, minus one-half the secondary voltage. The addition and subtraction must be performed vectorially, however.

Now when both circuits are tuned to the same frequency the secondary current is 90° out of phase with the primary current at resonance. The voltages developed across primary and secondary are consequently also 90° out of phase. The input to one diode is thus the primary voltage plus a voltage leading it by 90° and to the other diode is the primary voltage plus a voltage lagging on it by 90° . These voltages add vectorially to equal magnitudes, so at resonance the diodes have equal inputs. The outputs are thus also equal and add to zero.

Away from resonance the primary and secondary voltages are still equal for the same degree of mistuning from resonance, but their relative phase angles are different. The voltage induced in the secondary is still 90° out of phase with the primary current, but away from resonance the secondary current is no longer in phase with this induced E.M.F.

Suppose the degree of mistuning is such that the secondary current is 30° out of phase with the induced E.M.F. Then the voltage applied to one diode consists of the primary voltage plus one-half secondary voltage at 60° to it, and to the other diode it is the primary voltage plus one-half secondary voltage

AUTOMATIC FREQUENCY CONTROL

at 120° to it. The two add up to different magnitudes and the diode inputs are consequently unequal.

The band of frequencies over which control is secured is governed by the Q of the tuned circuits and the coupling between them. The user, however, is less concerned with these than with the adjustment of the circuits. They must be adjusted for resonance at the intermediate frequency, and to a first approximation this may be done by trimming them for maximum output as indicated by a meter connected in series with R_1 .

With over-coupled circuits, however, this alone is not likely to be sufficient and it will generally be necessary to check the adjustment. The first step is to make sure that the diode inputs are equal at the intermediate frequency with the aid of a valve voltmeter across the A.F.C. line.

Having obtained a zero voltage across this line, check that equal degrees of mistuning on either side of resonance give approximately equal magnitude of A.F.C. voltage but of opposite polarity.

Faults which may develop in A.F.C. systems are of the same nature as those in other parts of the receiver and can be traced by normal testing methods. In general fault-finding on an A.F.C.-equipped receiver, of course, it is a wise plan to disconnect, or otherwise render inoperative, the frequency-control stage. The simplest and most satisfactory way is usually to short-circuit the A.F.C. line.

Fault-finding in the other parts of the receiver can then be done on the normal lines dealt with in the earlier parts of this book. Troubles which may develop in the A.F.C. system itself are usually of a fairly simple nature and probably the commonest is misalignment of its tuned circuits. This can have a very serious effect on the performance of the receiver, for instead of A.F.C. performing its proper function of keeping the receiver always tuned to the signal it will then consistently keep it mistuned from the signal.

When an A.F.C.-equipped receiver behaves as though it were always somewhat mistuned from a signal—and this is evident by its effect upon the quality of reproduction—it is almost certain that the trouble lies in the adjustment of the tuned circuits in the discriminator.

Other troubles, such as unequal outputs from the diodes and short-circuits, partial or complete, on the A.F.C. line are most easily detected with the aid of a D.C. valve voltmeter. An ordinary voltmeter is not of great assistance, for its resistance will be low compared with that of the circuit and its indications will consequently be misleading.

CHAPTER 23

PUSH-PULL AMPLIFIERS

MUCH confusion exists in regard to push-pull amplifiers, and defects are often suspected when none in fact exists. A common complaint is that the removal of one of the push-pull output valves causes a very small drop in volume and does not apparently introduce distortion. This is no indication of any defect and is an entirely normal result. It must be remembered that although the removal of one valve halves the output, this represents a drop in volume of only 3 db. which is by no means a large amount. Furthermore, distortion is not always apparent because the removal of one valve lightens the load on the mains equipment with the result that an abnormally high voltage is applied to the remaining one and its undistorted output is consequently increased.

Because of this rise in voltage, the practice of withdrawing one output valve must be considered unwise, and it is definitely dangerous to valve life to do so when both output valves have a common bias resistance. The remaining valve will then be grossly overrun and is unlikely to survive such treatment unharmed.

Another effect often found on removing one valve is that whereas the removal of one has little effect, the removal of the other instead results in motor-boating. Again this is no indication of a defect. One of the great advantages of push-pull is that less decoupling is needed for the avoidance of feed-back effects than if a straight amplifier were used. All the advantage of the push-pull connection is lost when one output valve is removed and it is consequently only natural that feed-back effects should manifest themselves. Since the phase is opposite on the two sides of the push-pull stage, it follows that on the removal of one valve the feed-back will be degenerative and have little audible effect, whereas on the removal of the other it will be regenerative and may cause motor-boating.

True defects in a push-pull stage are usually of a fairly simple nature and consist of widely dissimilar valves and defective input or output transformers which can be checked by normal methods.

There are, however, some important differences between transformer and resistance coupled amplifiers. In the form in which is it usually found the transformer-coupled amplifier is balanced in each stage individually, and it is balanced not only for the signal but for feed-back. The resistance-coupled

PUSH-PULL AMPLIFIERS

amplifier does not provide an individual stage balance, but a balance on the signal for the complete amplifier only, and in most cases it is not balanced against feed-back.

A typical transformer-coupled amplifier is shown in Fig. 101. The first push-pull stage consists of V_2 and V_3 and is fed from an unbalanced input stage V_1 . The output stage V_4 , V_5 is again push-pull. The main advantage of push-pull lies in the output stage, for if the valves are alike even-order harmonics distortion is balanced out, and only odd-order harmonics appear in the output. With triodes, second harmonic distortion becomes apparent well before third harmonic in individual valves, so that the output obtainable from two valves in push-pull is greater than that from the same two valves in parallel.

In addition to this, the anode current flows in opposite directions through the two half-primary windings of the output transformer T_3 , and its core is consequently relieved of the magnetization inherent with a single-ended stage. This is very important, for it is economically almost impossible to design a transformer with a wide frequency response and a low distortion level for a large output stage of the single-ended type, whereas it is relatively easy with push-pull.

A transformer-coupled push-pull output stage is usually fed from an unbalanced stage, and a push-pull penultimate stage like that of Fig. 101 is used only when a single valve will not give sufficient output to feed the output stage. In general, a double push-pull amplifier is used only when the output valves need a very large signal input—of the order of 100 volts per valve or more.

The most likely defect in a transformer-coupled push-pull stage is a serious disparity between the valves. It is not difficult to check the balance of a stage. The easiest way is to connect a pair of headphones, shunted by a 100-ohm resistance, in series with the lead to the output transformer centre-tap. Disconnect the centre-tap on the input transformer and connect across the secondary a potentiometer with its slider joined to the bias source. The potentiometer can well have a resistance of the order of 0.2 megohm.

Varying the setting of this new and temporary control alters the ratio of the inputs to the two valves. The procedure, therefore, is to apply an input to the amplifier, preferably at about 400–1,000 c/s, and adjust the potentiometer for zero output in the phones. If the input is too great a good zero will not be obtained, but there will be a balance point for the fundamental and the second harmonic alone will be audible.

WIRELESS SERVICING MANUAL

Now check the resistance between the slider of the potentiometer and each of its ends, disconnecting it from the transformer while doing so. If the two values are the same, or nearly so, the valves and output transformer are sufficiently well balanced. If they are markedly different, however, interchange the two valves, rebalance, and measure the two new resistance values. If they are the same as before, the valves are alike, and the unbalance is in the output transformer. If the resistance values are also inter-changed, however, the output transformer is in order but the valves are unlike. Of course, if the resistance values have neither stayed unchanged nor inter-changed, both valves and transformer are at fault.

The input transformer is less easy to check, and the best way is probably to measure the voltages across its two halves with a valve voltmeter. A rough check can be obtained, however, during the preceding tests with the potentiometer. Adjust the input level so that a fairly sharp balance on the control is obtained, then change over to the normal input connections without the potentiometer, and note whether the fundamental is still inaudible in the phones. If it is, the input transformer is probably satisfactory.

It will be noted that the bias resistances R_3 and R_4 are shown in Fig. 101 without by-pass condensers. This is good practice when the stages are Class "A", for the resistance gives a considerable degree of self-balancing action to the stage and makes inequalities in the valves of much less importance. It does tend, however, to increase the odd-order harmonic distortion in the output, but the increase is quite negligible for degrees of second harmonic distortion per valve up to some 10 per cent.

The omission of a by-pass condenser is permissible in all Class "A" stages and also in Class "AB" stages in which the non-linearity per valve is not large. It is not permissible in Class "B" stages, nor in Class "AB" stages having large non-linearity per valve. As a rough guide if on applying a signal giving full output the anode current for the stage rises above the value with no signal by more than about 10-15 per cent. a bias resistance by-pass condenser should be used.

It will be noted from Fig. 101 that each push-pull stage is balanced independently of the other. The input division and output combination is done in the transformers. Even the removal of a valve from the penultimate stage disturbs the balance of the output stage in no way.

The amplifier, too, is completely balanced as far as feed-back

PUSH-PULL AMPLIFIERS

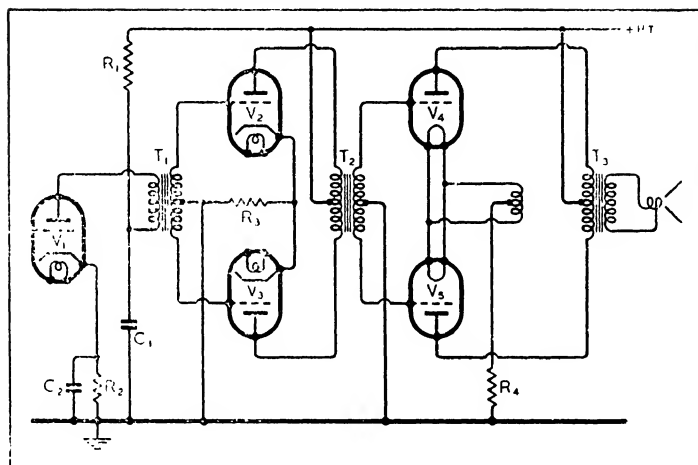

Fig. 101: A two-stage transformer-coupled push-pull amplifier takes the form shown in this diagram. The circuit is rarely used except in very large power amplifiers

effects from a common H.T. supply impedance are concerned. Imagine each push-pull stage to be perfectly balanced. Then in either stage any disturbance on the H.T. line will cause equal changes of anode current in the valves of a stage, and these will cancel in the transformer and induce no voltage in the secondary.

A disturbance in the H.T. supply to the first valve V_1 , however, will pass right through the amplifier, for it will act like an input signal and induce equal and opposite voltages in the two halves of the secondary. The anode currents of the following valves will change by equal and opposite amounts, so that there will be no change in the total current drawn by a push-pull stage.

Although a disturbance in the H.T. supply to the first valve may pass through the amplifier, because it does not affect the combined anode currents of the push-pull stages, it cannot produce a fresh disturbance on the H.T. line. Feed-back will not exist, and there is no need to decouple the first stage.

In practice, with a two-stage push-pull amplifier, it is usually wise to include some decoupling, because no practical amplifier ever is perfectly balanced. Moreover, distortion may occur at

WIRELESS SERVICING MANUAL

large outputs through harmonics of the signal being fed-back. This is more likely with Class "AB" than with Class "A". With only a single push-pull stage, it is rarely necessary to decouple the penultimate stage, but earlier stages must be decoupled.

Transformer coupling in push-pull stages is used chiefly with Class "AB₂" and Class "B₂" output stages, and resistance coupling is more common with Class "A" and Class "AB₁" stages. A resistance-coupled push-pull amplifier comprises four items—a phase-splitting input device, which may be a transformer or some valve arrangement, two identical R.C. amplifiers, and an output phase-combining device, which is

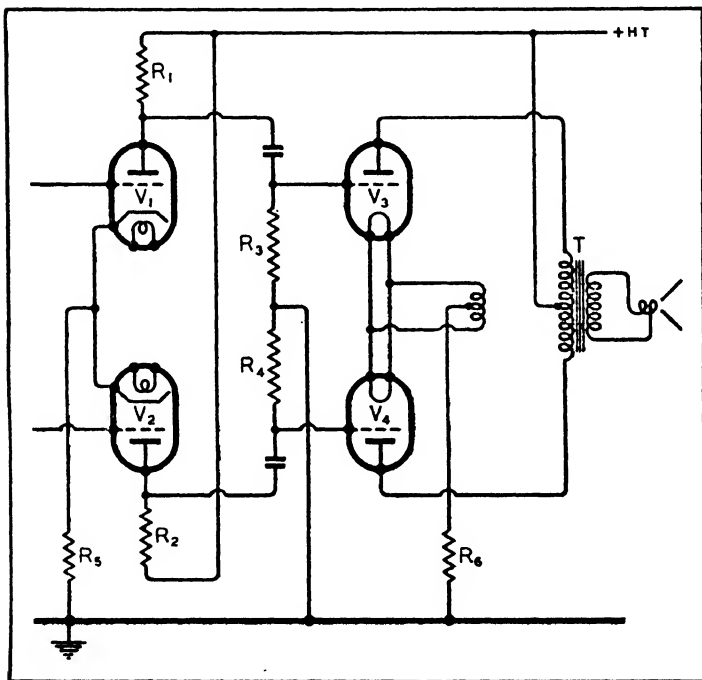

Fig. 102 : A two-stage resistance-coupled push-pull amplifier is frequently found in high quality equipment. In general, the bias resistances do not need by-pass condensers

PUSH-PULL AMPLIFIERS

invariably a transformer. In common parlance, the output stage consists of the last valve in each amplifier taken together, and the penultimate stage consists of the last but one in each amplifier. Thus, in Fig. 102, V_1 and V_3 form one of the R.C.

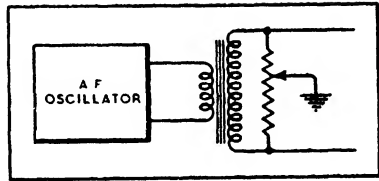

Fig. 103 : As explained in the text, the balance of a push-pull amplifier can be checked with this simple apparatus

amplifiers and V_2 and V_4 the other, but V_3 and V_4 form the output stage, and V_1 and V_2 the penultimate stage.

This diagram contains only three of the four items mentioned above, for the input circuit is not shown. This is because there are so many different types, and a selection of them is illustrated later in separate diagrams. Referring again to Fig. 102, the important thing to note is that the two stages are not independently balanced as in the case of transformer coupling. If V_3 and V_4 are identical but V_1 and V_2 are not, the whole amplifier is unbalanced and not merely the penultimate stage. Save for the bias resistances, the two amplifiers are completely independent between the input and output circuits.

If the individual sides of a stage are alike, and its valves have equal inputs in opposite phase, the alternating currents through the bias resistance are equal and opposite. Feed-back effects are then non-existent. If the sides of a stage are not identical, however, the bias resistance provides a self-balancing action just as in the case of transformer coupling. The omission of a by-pass condenser is equally, and under the same conditions, good practice.

In order to secure good balance it is not sufficient for the valves and their inputs to be alike; the coupling resistances must also be matched. In Fig. 102, for instance, R_1 and R_2 should have the same value, while R_3 should equal R_4 . A reasonable degree of equality would be within 5 per cent., but 2 per cent. is better, especially if there is no by-pass condenser across R_5 . This is because feed-back on R_5 accentuates unbalance caused by inequality of the coupling resistances, while reducing that produced by the valves. It is easier to match resistances than valves, so that the condenser is usually omitted.

The equality of the couplings is easily checked by measuring

WIRELESS SERVICING MANUAL

the resistance and capacity values. The first stage balance can then be checked by applying an input from an A.F. oscillator through the circuit of Fig. 103 and listening with a pair of headphones connected across R_5 . A condenser should be connected in series with the phones to avoid disturbing the bias.

The potentiometer is adjusted for zero fundamental component in the phones and the two halves of its resistance checked, exactly as described for transformer-coupled amplifier. When good balance has been obtained in the first stage, the second can be tackled in the same way, but this time listening with the phones connected across a low resistance in the lead to the output transformer centre-tap.

The phase-splitting arrangements for resistance-coupled push-pull amplifiers vary greatly, and some of the commonest arrangements are shown in Figs. 104-108. The first is that of Fig. 104 and it will be seen that it consists of a direct connection between the input and one side of the output, and a valve stage between the input and the other side of the output.

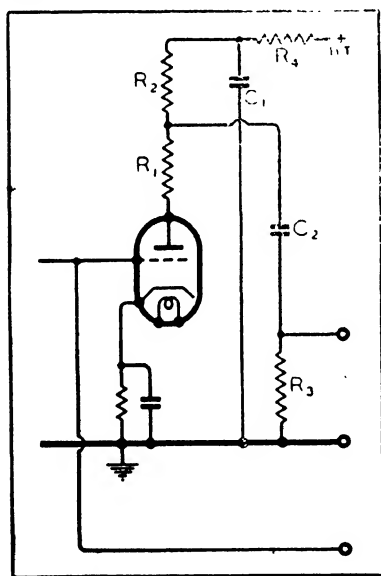

Fig. 104 : Phase-reversal for one push-pull input is obtained by an R.C. stage of unity amplification

There is a reversal of phase in this valve stage, and the correct output is secured when it gives unity amplification. The output is taken from the junction of R_1 and R_2 , which must be proportioned correctly. The balance condition is $\mu = 1 + (R_a + R_1)(R_2 + R_3)/R_2R_3$. Typical circuit values might be $\mu = 40$; $R_a = 15,000 \Omega$; $R_1 = 40,000 \Omega$; $R_3 = 0.25 \text{ M}\Omega$; and $R_2 = 1,400 \Omega$.

A modification of the circuit is shown in Fig. 105. This has the advantage of giving a slightly lower hum level and is more frequently used, particularly in American sets. The balance

PUSH-PULL AMPLIFIERS

condition is $\mu = (1 + R_a/R_1) (1 + R_3/R_4) + R_a/R_4$. Typical values are $\mu = 40$; $R_a = 15,000 \Omega$; $R_1 = 50,000 \Omega$; $R_3 = 0.25 \text{ M}\Omega$; and $R_4 = 8,800 \Omega$.

Another common circuit is shown in Fig. 106 (a). The two outputs are taken from the anode and cathode circuits and are consequently in opposite phase. They are equal in value if $R_3 = R_1 + R_2$ and $R_5 = R_6$. Bias is provided by R_2 which usually has a value of some 2,000 ohms, while R_1 and R_3 may be 48,000 ohms and 50,000 ohms respectively. Sometimes C_3 is joined directly to the junction of R_1 and R_2 , and sometimes R_2 is shunted by a large capacity; in

both these cases R_2 does not contribute to the output voltage and so the balance condition becomes $R_1 = R_3$. The circuit of Fig. 106 (b) is identical save for the method of obtaining grid bias. Instead of deriving it from the voltage drop across a resistance in the cathode circuit, it is taken from a tapping on a potentiometer R_4, R_5 across the H.T. supply. This variation of the circuit is not often found.

The main practical difficulty that may be encountered with this circuit is hum arising from poor heater-cathode insulation in the valve. There is usually little difficulty if one side of the valve heater is earthed, but there will undoubtedly be trouble if the heater is joined to cathode or left floating. Earthing the heater means that the cathode voltage appears across the heater-cathode insulation, but as it rarely exceeds 50 volts, most valves will withstand it without difficulty.

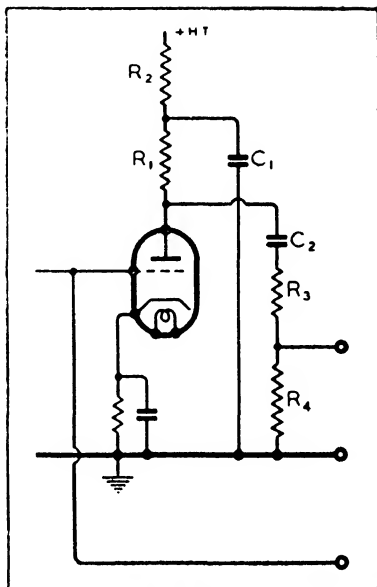

Fig. 105: This diagram is a modification of that of Fig. 104, the output being taken from a tapped grid leak R_3, R_4 instead of a tapped coupling resistance

WIRELESS SERVICING MANUAL

With some people this circuit has acquired a bad reputation for hum, but the author has used it extensively without any difficulty at all, and he considers it the most reliable and satisfactory of all the phase-splitting circuits. In one amplifier embodying it, the valve has had some 10,000 hours operation in the circuit and it still functions without hum.

It should be pointed out that the grid circuit of the valve is of unusually high impedance and so unusually sensitive to pick-up from the electric hum-field. The grid leak R_7 is usually about 2 megohms, but to any voltage applied between grid and earth its value is much more than this. The cathode voltage changes are nearly equal to the grid voltage changes, both with respect to earth, and only the difference between these voltages can drive alternating current through the grid leak. The effective value of the grid leak is some 15-20 times its actual value, and may well be 30-40 megohms. Because of this it is possible to make C_4 about one-twentieth of the normal value without a loss of bass response. If this is done, however, the effective impedance between the grid of the valve and

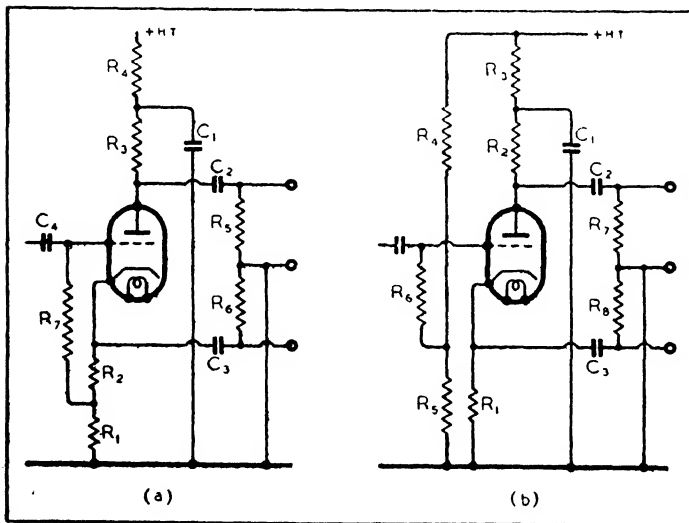

Fig. 106: The circuit (a) represents one of the most widely used phase-splitters. The arrangement (b), which differs only in the method of obtaining grid bias, is less commonly adopted

PUSH-PULL AMPLIFIERS

earth will be very high indeed, and the liability of the stage to hum pick-up will be about twenty times as great as that of a normal stage. If C_4 is given a normal value, however, the impedance at hum frequencies will be normal, and the stage will not be unduly sensitive to hum pick-up. Nevertheless, it is well to keep the leads between the grid and C_4 and R_7 very short, and well away from any mains equipment.

Another phase-splitting circuit occasionally employed is that of Fig. 107. One output is taken from the anode of V_1 and is in opposite phase to the input. The voltage across the cathode resistances R_3 and R_4 is applied to the cathode of V_2 ; this voltage is in the same phase as the input and produces an output at the anode of V_2 which is still in the same phase.

If R_1 and R_2 are equal, equal outputs demand equal alternating anode currents, but as the currents are in opposite phase, this would mean that there could be no alternating voltage across R_3 and R_4 . There would then be no input to V_2 , and there could be no output from it. The alternating currents in the two valves cannot, therefore, be equal.

The condition for equal outputs is that $\frac{R_2}{R_1} = 1 + \frac{R_2 + R_2}{(R_3 + R_4)(1 + \mu_2)}$ where μ_2 and R_{a2} are the amplification

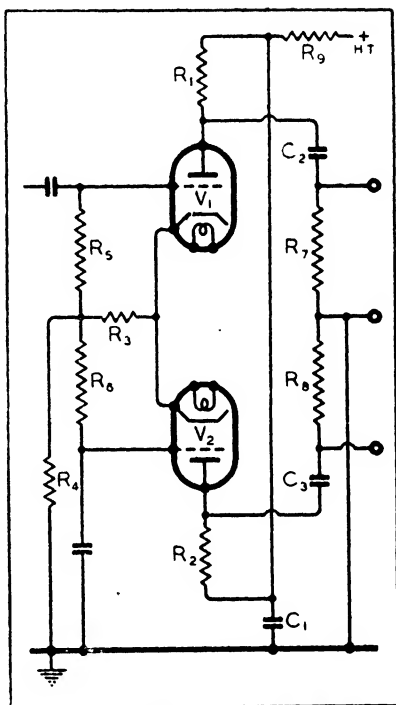

Fig. 107 : In this phase-splitter V_1 acts as a cathode-follower to feed a cathode-input stage V_2 , as well as providing an output from its anode circuit

WIRELESS SERVICING MANUAL

factor and A.C. resistance respectively of V_2 . The current unbalance is then $(R_2 - R_1)/(R_2 + R_1)$. The current unbalance should preferably be less than 5 per cent., which means

$$R_2 = 1.1R_1 \text{ and this in turn means } R_3 + R_4 = 10 \frac{(Ra_2 + R_2)}{(1 + \mu_2)}$$

Typical values are $\mu_1 = \mu_2 = 40$; $Ra_1 = Ra_2 = 15,000$ ohms; $R_1 = 50,000$ ohms; $R_2 = 55,000$ ohms; $R_3 + R_4 = 17,000$ ohms. For correct bias, R_3 would be about 1,000 ohms, making R_4 some 16,000 ohms.

One disadvantage of this circuit is the high positive cathode potential, for the steady anode currents of both valves flow through R_3 and R_4 . This particular phase-splitter is usually employed to feed an output stage directly, and then a current of 2 mA. or more per valve is needed. This makes the cathode potential 70 volts or more above earth. With some valves this is an excessive difference of heater-cathode potential, and yet the heater must be effectively earthed if hum is to be avoided. The difficulty can be got over by using a separate heater winding for V_1 and V_2 ; it can then be connected to earth through a large capacity condenser and to cathode through a high resistance. The heaters are then earthed for A.C., but connected to cathode for D.C. This same method of arranging the heater circuit can also be employed with the phase-splitter of Fig. 106. It is usually unnecessary, however, for as this valve usually precedes the penultimate stage it is possible to secure sufficient output without an excessive heater-cathode potential difference.

The next circuit is the paraphase arrangement of Fig. 108. Again this is usually employed immediately before the output stage, and it will be seen to consist of two R.C. stages in which one is fed from the junction of two resistances joining their anodes. Its advantage is that some self-balancing action is secured. The grid potential of V_2 depends on R_6 and R_7 , but also on the anode potentials of V_1 and V_2 . If the gain of V_2 falls for some reason the output of V_2 falls, and the current through R_6 and R_7 is less. Consequently the voltage drop across R_6 is reduced, and the grid potential of V_2 increased. This tends to increase the input of V_2 , and the result is that the fall in output of V_2 is not equal to the drop in the gain of this valve.

When the two valves are alike and when $R_4 = R_5$ and $R_8 = R_9$ the balance condition is given by

$$\mu \left(1 - \frac{R_6}{R_7} \right) = \frac{Ra}{R_7} \left(2 + \frac{R_6}{R_2} \right) + \left(1 + \frac{Ra}{R_{11}} \right) \left(1 + \frac{R_6}{R_9} + \frac{R_6}{R_2} \right)$$

PUSH-PULL AMPLIFIERS

$$\text{where } R_{11} = \frac{R_4 R_8}{R_4 + R_8} = \frac{R_5 R_9}{R_5 + R_9}$$

Typical conditions are $\mu = 40$; $R_a = 15,000 \Omega$; $R_2 = 0.5 M\Omega$; $R_3 = 1,000 \Omega$; $R_4 = R_5 = 50,000 \Omega$; $R_6 = 87,500 \Omega$; $R_7 = 100,000 \Omega$; $R_8 = R_9 = 0.25 M\Omega$.

It will be noted that in all these circuits H.T. decoupling is shown. This is essential, because none of them is balanced from the viewpoint of the H.T. line, and this is a disadvantage of R.C. push-pull as compared with transformer coupling. As an example, imagine the phase-splitter of Fig. 106 (a) connected in front of the amplifier of Fig. 102. A disturbance on the H.T. line—say, a rise of voltage—increases the anode current of the phase-splitter. Let the rise of voltage be E and the current i . Then if $R_3 = R_1 + R_2$ (Fig. 106 (a)) the output at the upper terminal is $E - iR_3$ and at the lower terminal it is iR_3 . These two outputs are in the same phase and unequal.

The grids of V_1 and V_2 of Fig. 102 are thus driven positively by unequal amounts, and consequently the grids of V_3 and V_4 are driven negatively by unequal amounts. The anode currents of V_3 and V_4 fall and as they both change in the same direction they are additive in the H.T. lead. The total anode current of the stage thus falls and also the drop across the impedance of the H.T. supply system, giving a rise of H.T. voltage. This is applied to the phase-splitter and as the original rise of voltage has caused a further rise, the action is regenerative. With an odd number of stages following the phase-splitter feed-back to it is degenerative, but with an even number it is regenerative.

The two sides of a resistance-coupled amplifier, even apart from the phase-splitter, operate in parallel as far as feed-back effects are concerned. Consequently, the advantage of being able to use little or no decoupling, which is found with transformer-coupled amplifiers, is absent.

However, negative feed-back caused by the H.T. source impedance does not necessarily affect the performance from the point of view of the signal. In a single-sided R.C. amplifier, it causes a drop in bass response, but in a push-pull R.C. amplifier it does not, because under linear conditions the two sides can operate in push-pull for the signal and in parallel for feed-back voltages without interaction between the two. Under non-linear conditions feed-back is liable to increase amplitude distortion somewhat.

Positive feed-back is similarly harmless unless it is sufficient to give rise to motor-boating. The valves are then driven

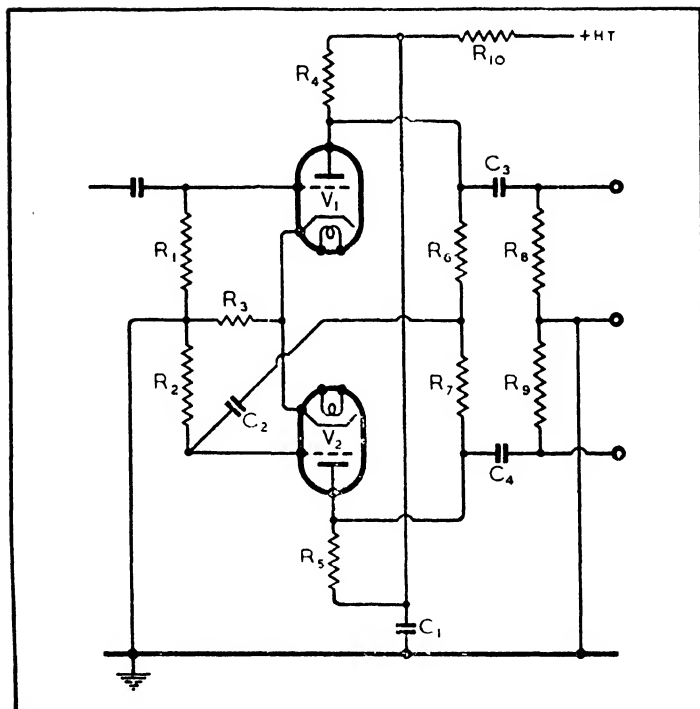

Fig. 108 : In the paraphase form of phase-splitting circuit, there is a considerable amount of self-balancing action

between current cut-off and grid current alternately and the signal path is seriously affected.

In general, with Class "A" and "small" Class "AB" output stages, it is satisfactory to omit decoupling in the penultimate stage, but the stage before that must be heavily decoupled. Thus, if Fig. 106 (a) precedes Fig. 102, the anode circuits of V_1 and V_2 in the latter need not be decoupled, but R_4 and C_1 in the former will have to be about 50,000 ohms and 8 μ F. respectively. With "heavy" Class "AB" and Class "B" stages the penultimate stage should be decoupled also in order to prevent distortion arising through harmonics of the signal being fed back.

PUSH-PULL AMPLIFIERS

Some phase-splitting circuits include a balancing adjustment. Thus, in Figs. 104 and 105, R_1 and R_2 in the former and R_3 and R_4 in the latter may be a potentiometer with the output taken from the slider. In Fig. 106 (a) R_1 or R_3 may be a variable resistance, and in (b) R_1 or R_2 may be variable. Similarly, in Fig. 107 R_1 or R_2 may be variable or they may be joined to the ends of a potentiometer, the slider of which is connected to H.T., while in Fig. 108 R_6 and R_7 are often a potentiometer.

The adjustment is easily carried out by feeding the amplifier from an oscillator, preferably at about 400-1,000 c/s, and adjusting the balance control for minimum output in a pair of phones connected across a low resistance in the lead to the centre-tap on the output transformer primary. As an alternative to this, adjust the input to give a convenient output in the loudspeaker and then change the connections of the output stage from (a) of Fig. 109 to (b); that is, transfer one of the "anode" connections on the output transformer to the other "anode" terminal. The balancing control can then be adjusted for minimum output. Ideally this would be zero but in practice a trace of the signal may remain.

If the input is large, it will be found that there is a considerable output at the balance point but the note is an octave higher than the input. This is because the output is the second harmonic of the input and, as the valves are not connected in push-pull, it is not balanced out. When the balance

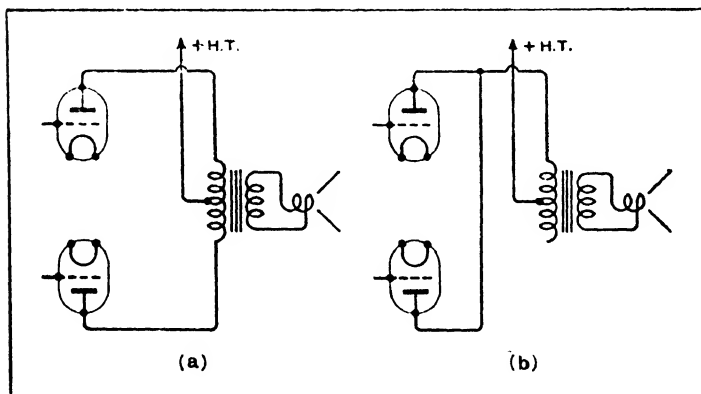

Fig. 109 : The change of connections shown at (b) is often useful when balancing a push-pull amplifier

WIRELESS SERVICING MANUAL

point has been determined, the connections to the transformer can be replaced to normal.

A difficulty which occasionally arises with resistance-coupled push-pull amplifiers is a lack of balance at very low frequencies, usually well below audibility. None of the circuits described is completely symmetrical. In Figs. 104, 105, 107 and 108 there is one more R.C. coupling in one side of the chain than in the other, and in Fig. 106 there is the impedance of the decoupling circuit on one side but not on the other.

By using suitable circuit values the lack of symmetry only becomes apparent at very low frequencies and does not affect the signal performance. It does sometimes, however, lead to motor-boating through feed-back to an I.F. or R.F. valve. Low-frequency voltages developed across the impedance of the H.T. supply can produce motor-boating, which occurs only when a signal is tuned-in, by modulating the carrier in an R.F. or I.F. valve. Fortunately, it is a rare defect.

The proper remedy is to decouple the H.T. supply to the R.F. and I.F. valves, but this is rarely possible on account of the heavy current which they draw. The best course, therefore, is to reduce the gain at very low frequencies by reducing the values of the coupling condensers and grid leaks as much as possible without appreciably affecting the bass response. When this is done the condensers and grid leaks in each stage should be matched as closely as possible. The odd coupling (C₂, R₃ in Fig. 104 and similar components in others) should be made as large as possible to preserve symmetry.

Parasitic Oscillation

None of the circuits illustrated includes grid or anode stopping resistances. It is customary to include such resistances in push-pull amplifiers to prevent parasitic oscillation. They are rarely needed anywhere but in the output stage, and not always there.

With transformer coupling parasitic oscillation at a low radio-frequency is theoretically possible with certain transformer characteristics. For it to occur it is necessary that the leakage inductances of the transformers and the various stray capacities to be correctly related, so that they form tuned grid and tuned anode circuits with fairly close resonance frequencies. If this occurs, the use of a grid stopper of some 0.1 megohm for each output valve would be an effective cure, but the author has never met a case.

PUSH-PULL AMPLIFIERS

Parasitic oscillation is usually at a very high radio-frequency and can occur with either transformer or resistance coupling. The valve and wiring capacities and inductances form resonant circuits and turn the stage into an U.S.W. oscillator. The best cure is to make the connections so short that at least one of the circuits is resonant at a frequency above any at which the valves will oscillate, and to make the frequencies of the others very widely different.

This is not usually difficult, for it is generally easy to lay out the apparatus so that all leads on the grid side of the output stage are very short, and it often happens that the leads to the output transformer are fairly long.

The second method of attack lies in damping the resonant circuit by means of grid and anode stopping resistances. To be effective they must be mounted directly on the valve holder with very short leads. If care be taken in the wiring, as described above and a 50-ohm stopper is connected in each anode lead, trouble is very unlikely. If parasitic oscillation is found in spite of these precautions, try 10,000-ohm grid stoppers as well.

With pentode output valves the screen circuits are equally or more important, and 50-ohm stoppers should normally be connected in the screen leads. The difficulties of parasitic oscillation are often greatly exaggerated, however, and if the layout is good, most amplifiers will work well without stopping resistances. The author usually includes them as a precaution rather than of necessity.

The symptoms of parasitic oscillation are distortion and low output. The anode currents will be markedly different from the correct ones in most cases. With transformer coupling the currents may be very high, and if the oscillation is allowed to persist the valves will have only a short life. With resistance coupling the currents are likely to be abnormally low. The effect on valve life may still be bad, however, for there will be grid current and some output valves are not built to withstand appreciable grid current.

CHAPTER 24

MISCELLANEOUS DEFECTS AND ADJUSTMENTS

THE chief defects encountered in wireless receivers, and the methods which are best adapted for tracing them, have been described in detail in the preceding chapters. By following the procedure laid down, the location of many faults becomes almost an automatic process. More obscure troubles, of course, may fail to submit to straightforward testing, but in the majority of cases little difficulty will be found in devising suitable tests and drawing the correct deductions from their results. There is, however, a number of faults which, although essentially simple in origin, prove puzzling to the tester, and before concluding it is felt that a few remarks on defects of this nature may prove helpful.

One of the simplest circuit arrangements is capable of providing symptoms which can be quite puzzling until one has learnt to recognize them. Small straight sets are usually fitted with reaction in order to obtain adequate sensitivity and selectivity, and it sometimes happens that although the receiver functions well on the medium waveband reaction fails to work properly on the long waveband, or only functions over a portion of the band. The disconcerting feature of this defect is that it is quite possible to make the detector oscillate by increasing the setting of the reaction control, but it fails to have any appreciable effect on sensitivity and the characteristic whistle is often absent when tuning through a station.

The trouble is only that the valve is oscillating at a frequency determined by the constants of the anode circuit instead of the grid circuit. It usually occurs with circuits similar to Fig. 110, when a single reaction coil does duty for both wavebands and only the tuning coil in the grid circuit of the valve is switched. On the long waveband, the reaction circuit sometimes takes control and an increase in reaction has no effect on the signals to which the grid circuit is tuned. When the reaction condenser is advanced sufficiently, oscillation commences, usually with a plop, but at a frequency determined by the reaction circuit. A further advance in the setting of the control may cause the oscillation to change over to the correct frequency of the grid circuit, and the normal heterodyne whistles will then be obtained.

The remedy for this state of affairs is usually very simple and consists of nothing more than the insertion of a resistance in

MISCELLANEOUS DEFECTS AND ADJUSTMENTS

series with the reaction coil, so that the reaction circuit is heavily damped and oscillation at any frequency determined by it is prevented. This resistance is shown at R in Fig. 110 and its value should be as high as possible consistent with proper reaction effects being obtained throughout the tuning range of the receiver.

It will generally be found that a resistance of 500 ohms will prove satisfactory, but in some cases it will have to be lower in order to obtain proper reaction effects, and in others it must be higher to prevent oscillation at the wrong frequency.

Apart from push-pull stages, balancing operations are not often required nowadays. Occasionally, however, neutralised R.F. amplifiers are met with in old receivers, and are likely to require rebalancing, particularly if new valves are fitted. When only one R.F. stage is used, it is possible to adjust the neutralising merely by setting the neutralising condenser to the point at which stability is maintained throughout the tuning range.

A more refined procedure is necessary when the amplifier includes more than a single stage, however, and is really advisable even when there is only one valve. The test oscillator should be set to about 1,200 kc/s and its output connected to the grid circuit of the stage preceding the one to be adjusted. The neutralising condenser should be set at minimum and the

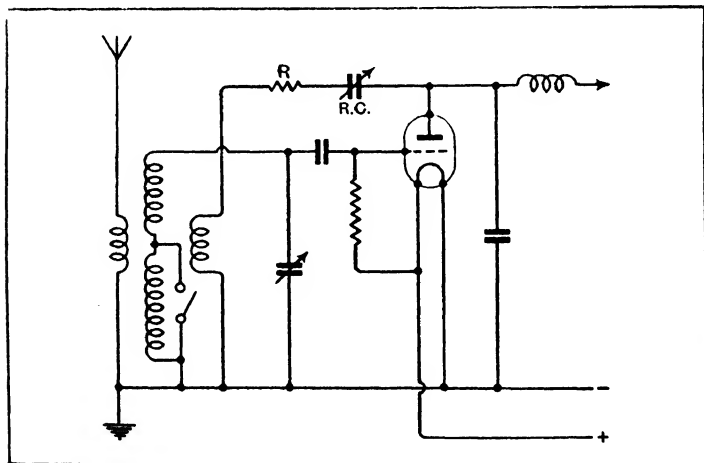

Fig. 110 : This diagram shows a typical reaction circuit

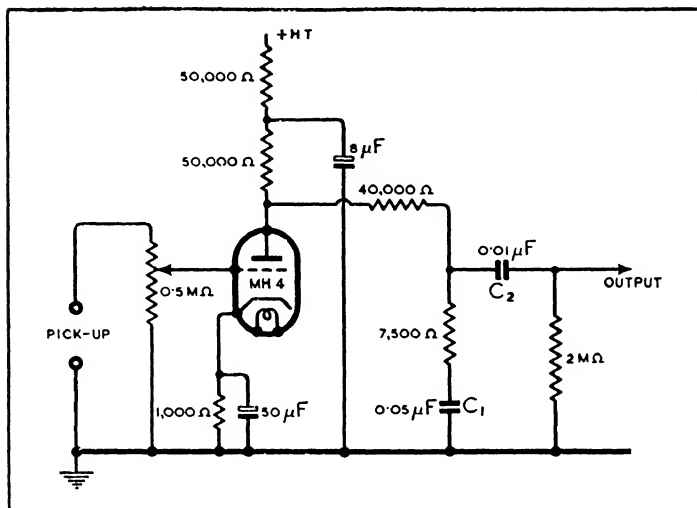

Fig. 111 : This diagram illustrates a simple bass boosting circuit designed to compensate for the recording deficiencies

positive L.T. lead to the valve concerned disconnected (in the case of indirectly heated valves, one of the heater leads). The signal from the test oscillator should then be accurately tuned in, and it will be found that sufficient energy will be passed by the valve capacity for this to be readily done in spite of the valve being inoperative.

The neutralising condenser should then be adjusted for minimum output, and this setting should be clearly defined. The filament or heater connections can then be replaced, and the stage should be found to give definite amplification and be quite stable.

The output of the oscillator can then be transferred to the preceding stage and the next earlier valve in the chain neutralised in the same way, the oscillator being finally connected to the aerial and earth terminals while the first R.F. stage is adjusted. The most widely used neutralised receivers were fitted with only a single R.F. stage and there should be little difficulty with any of these.

Two-R.F. sets were used fairly widely at one time, however, and sets with as many as five R.F. stages have been produced

MISCELLANEOUS DEFECTS AND ADJUSTMENTS

commercially. The difficulties of neutralisation are, of course, much greater with these, and it may be remarked that in some cases better neutralisation is secured when small resistances are inserted in series with the neutralising condensers. It should also be remembered that such circuits are often rather prone to parasitic oscillation, particularly those types embodying tapped tuned circuits.

Provision is made in most receivers for the connection of a gramophone pick-up, but this is usually no more than a switch which enables the pick-up terminals to be connected to the A.F. volume control in place of the detector output. Apart from a bad contact in the switch, therefore, there is nothing in the average receiver which is likely to prove faulty on gramophone but which does not show up also on radio.

Gramophone Pick-up

The pick-up itself, however, can develop faults which vary with the type of pick-up. Apart from such obvious defects as open-circuits in the windings and leads, which are readily found with an ohmmeter, the usual faults are mechanical rather than electrical. In most cases, the needle-holder and armature are mounted in rubber supports; in the course of time the rubber perishes, and the armature chatters against the pole pieces. When the rubber is badly perished, the armature may be found adhering to one of the pole pieces.

The remedy is, of course, to fit new rubber suspension, and it is not difficult to do this in most cases if a little ingenuity is exercised. It is necessary, however, to be careful to make the suspension free enough. The suspension should be as free as possible consistent with the needle's being able to support the pick-up head on the record without bringing the armature into contact with the pole pieces. Excessive stiffness means record wear and, probably, resonance within the audible range.

The same principles of avoiding stiffness in the needle mounting apply to other types of pick-up, such as the piezo-electric, but here, of course, there is no question of an armature and pole pieces. The needle-holder is linked to the crystal so that its movement stresses the crystal and it produces an output voltage by virtue of its piezo-electric property. Apart from the rubber bushing of the needle-holder, the most likely defects are in the mechanical linkage to the crystal and in the crystal itself. The latter usually means a new crystal.

It should be pointed out that it is of no use testing a crystal

WIRELESS SERVICING MANUAL

pick-up for continuity, for the crystal is of infinite D.C. resistance. One should, however, check the leads.

The tone arm itself should not be overlooked, for it can be responsible for low-frequency resonances, chatter, and heavy record wear. Special points to watch are joints and swivels. Some tone arms have a rotatable head for easy needle changing. This joint should be stiff to turn and when in the playing position free from any trace of wobble.

All tone arms have joints of some kind which enable the head to move both vertically and horizontally. Usually they are both placed together at the pick-up mounting, but sometimes there is only a rotating joint permitting horizontal movement at this point, and the vertical movement is provided by a joint where the pick-up head is attached to the tone arm.

Whatever the precise arrangement, the joints must be free from any looseness, but at the same time they must be completely free. Any appreciable friction will cause record wear.

Some pick-ups are designed to have a steadily rising frequency characteristic below about 500 c/s. This is done in order to correct for the falling characteristic used in recording. Such a pick-up characteristic is not an unmixed blessing, however,

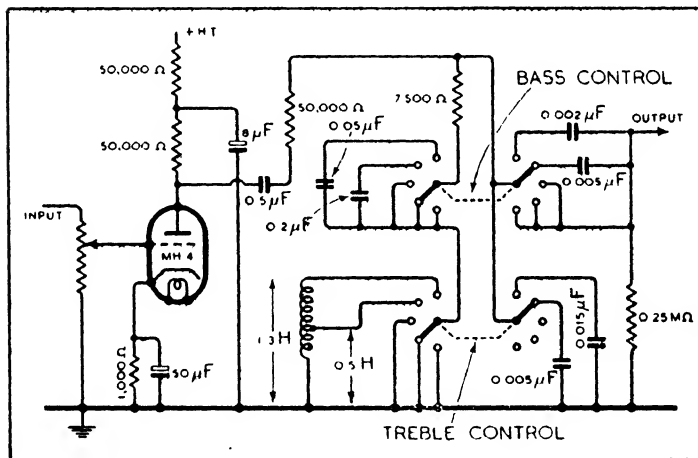

Fig. 112 : Independent bass and treble tone controls are obtainable with this circuit. Care must be taken in positioning the treble accentuation-choke, for it is very liable to pick-up hum

MISCELLANEOUS DEFECTS AND ADJUSTMENTS

for it is often achieved by the suitable placing of a bass resonance, and this usually means increased record wear. Often, too, the increasing bass is accompanied by non-linearity.

With the better quality pick-ups, therefore, a flat characteristic is aimed at, and it is then necessary to provide bass compensation in the amplifier. This is quite easily done and a first-stage A.F. amplifier like that shown in Fig. 111 is very satisfactory. The voltage amplification is about 3.8 times at medium and high frequencies, and rises steadily below some 500 c/s.

A very good tone control stage can be built on these lines by providing a switch to change the value of C_1 . Smaller capacities than that shown will make the bass rise begin at higher frequencies, and larger capacities will make it start at lower frequencies. Replacing the capacity by an inductance will give a flat bass, but rising treble characteristic; inductance values of 0.5–1.5 H. are suitable. Capacity and inductance in series will make the response rise at both bass and treble.

Bass cut is easily arranged by providing a switch to reduce C_2 , and treble-cut with another switch to shunt capacity across the coupling. The switches can be linked to give two controls providing independent bass and treble tone controls which have a negligible effect upon the gain. The arrangement is shown in Fig. 112 and five different degrees of bass response are obtainable in any combination with five different degrees of treble response. Twenty-five different frequency characteristics are provided, therefore.

CHAPTER 25

NEGATIVE FEED-BACK

THE presence or absence of deliberate negative feed-back in an A.F. amplifier makes very little difference in fault-finding and troubles in the feed-back circuit itself are confined almost entirely to such simple things as faulty resistances. Its use is becoming common in the better broadcast sets, and in a few cases it is bound up with tone control systems, so that it may be as well to describe some of the principle methods adopted.

There are two kinds of negative feed-back—current and voltage. The former occurs when the voltage fed back to the input is proportional to the output current and the latter when it is proportional to the output voltage. Current feed-back increases the apparent output resistance of a stage, while voltage feed-back reduces it.

There is only one kind of current feed-back in common use and this is the feed-back obtained from an unbypassed cathode-bias resistance. The omission of the condenser reduces the

stage gain by the factor $1 / \left[1 + \frac{R_c (1 + \mu)}{R_a + Z} \right]$ where R_c is the

cathode resistance, μ and R_a are the amplification factor and A.C. resistance of the valve, and Z is the anode circuit coupling impedance. Where R_a is very large compared with Z , as in pentode stages, the factor reduces approximately to $1/(1 + gR_c)$ where g is the mutual conductance.

The great advantage of the feed-back is that it improves the linearity of a stage and so reduces amplitude distortion. Distortion is usually quite low in early A.F. stages, however, and feed-back within such stages is rarely needed to reduce it. In general, current feed-back is incidental to other requirements. For instance, in one very common circuit to be described later the feed-back is over two stages, and is applied to the cathode of the first. This necessitates the cathode resistance of the first stage being unbypassed, and so there is incidental current feed-back from it.

If the gain of an A.F. amplifier is too great, but not so great that a stage can be omitted, one or more bias resistances in the early stages are sometimes left without bypass condensers. The current feed-back reduces the gain, the linearity is improved to some extent, and the condensers are saved.

NEGATIVE FEED-BACK

Heavy current feed-back occurs in the push-pull phase-splitting circuit of Fig. 106, and makes the stage extremely linear. The feed-back is so great that the voltage amplification between the input and either of the two outputs is a little less than unity.

In all these circuits the increase of apparent output resistance resulting from the feed-back is unimportant. This is not the case in the output stage. Here it is desirable to have a very low output resistance in order to reduce distortion in the output transformer. The use of current feed-back at this point, although it may reduce valve distortion, tends to increase transformer distortion. The bias resistance of the output stage, therefore, should always be shunted by a large capacity condenser, except when using push-pull or one of the circuits with which grid de-coupling is permissible.

Negative voltage feed-back reduces the stage gain and improves the linearity just as much as current feed-back, but it

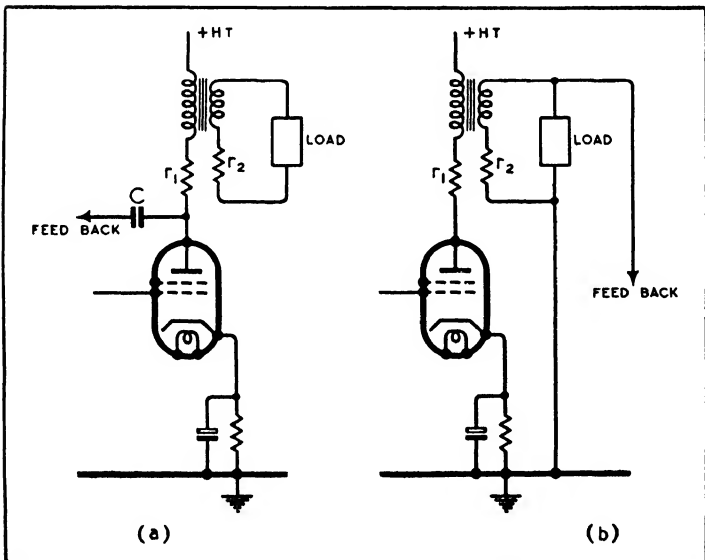

Fig. 113 : As explained in the text, it is usually better to feed-back from the transformer secondary, as at (b), rather than from the primary

WIRELESS SERVICING MANUAL

reduces the apparent output resistance of a stage. It is, therefore, almost invariably employed in the output stage.

The voltage to be fed-back is taken from one of two places—the anode of the output valve or the output transformer secondary. The latter alternative is adopted wherever possible and for two reasons; no isolating condenser is necessary in the feed-back path and the transformer winding resistances are reduced by the feed-back. This is shown in Fig. 113; the usual connections for feed-back from the valve anode are shown at (a) and an isolating condenser C is needed to keep the H.T. from the feed-back circuits. This is an additional component, and is disadvantageous because it introduces some phase-shift at low frequencies. The resistances r_1 and r_2 represent the transformer primary and secondary winding resistances. From the point of view of the transformer the effective resistance across its primary is $R_a + r_1$ without feed-back, and $R_a/k + r_1$ with feed-back.

With feed-back from the secondary as in (b), however, the effective resistance is $(R_a + r_1)/k$. If the transformer resistance is low, say under 200 ohms, and a moderate output resistance of perhaps 1,500 ohms is required, the difference between the two circuits is small. On the other hand, if the transformer resistance is at all large, and especially if a low effective resistance is

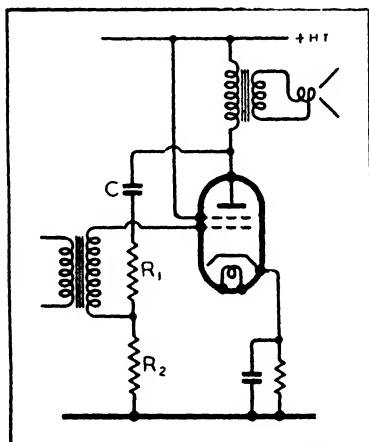

Fig. 114: With transformer coupling feed-back can be obtained over a single stage by using this circuit

needed, the difference can be quite big. Thus, suppose that the transformer resistance is 400 ohms and the effective resistance across the transformer primary is required to be 700 ohms, then with circuit (a) it is necessary to reduce by feed-back the valve resistance to 300 ohms only. With circuit (b), however, it is the valve resistance plus 400 ohms which must be reduced to 700 ohms; 400 ohms is still negligible compared with the valve resistance, so that virtually the valve resistance must be

NEGATIVE FEED-BACK

brought down to 700 ohms instead of to 300 ohms. Less feed-back will be needed, and the gain will be greater. In this case, for the same effective resistance on the transformer the gain will be $7/3$ times as great with circuit (b) as with circuit (a).

When feed-back takes place over the output stage alone, it is often necessary to feed-back from the valve anode because the voltage on the transformer secondary is not as a rule sufficient. The usual circuit for a transformer-coupled stage is shown in Fig. 114; the voltage amplification measured

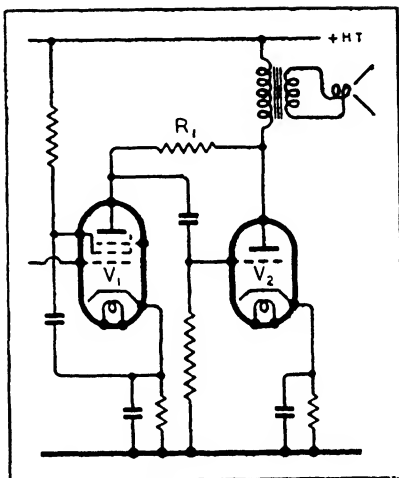

Fig. 115: This circuit is sometimes used and is very simple, but has certain disadvantages, as explained in the text

between the input transformer secondary and the output transformer primary is $A/(1 + A\beta)$ where A is the amplification without feed-back and β is the feed-back factor. In this case, $\beta = R_2/(R_1 + R_2)$ at frequencies for which the reactance of C is negligible. The output resistance $R_o = R_a/(1 + \mu\beta)$.

As an example, take a pentode with $g = 6\text{mA/V.}$ and an A.C. resistance of 60,000 ohms. Suppose that the load is 10,000 ohms, and that an output resistance of 1,000 ohms is required. Then $\mu\beta = 59$, and as $\mu = 360$, $\beta = 0.164$. The amplification without feed-back is 51.5 times, and with feed-back it is 5.45 times. Feed-back has reduced the output resistance to one-sixtieth of its normal value and the amplification to a little less than one-ninth.

For this amount of feed-back R_1 is 5.1 times R_2 , so that in practice, one would make R_2 about 30,000 ohms and R_1 some 150,000 ohms. A capacity C of 0.2-0.5 $\mu\text{F.}$ would be satisfactory.

A pentode of this type would normally need an input of perhaps 10 volts peak; with feed-back the voltage on the transformer secondary will be 51 volts peak. This must be supplied

WIRELESS SERVICING MANUAL

without distortion by the preceding valve. With transformer coupling, there is unlikely to be any difficulty in this, but the fact well illustrates a point which must be carefully watched in feed-back circuits. Feed-back reduces distortion in the circuits over which it is applied, but those circuits require a correspondingly larger input. The preceding circuits, therefore, must be designed to supply this larger voltage without distortion. If they are not, it is quite possible for the net effect of applying feed-back to be to increase distortion.

When resistance coupling is used the circuit of Fig. 115 is sometimes adopted and has the great merit of simplicity. The preceding valve is shown because the amount of feed-back is affected in some degree by its A.C. resistance. In general, this penultimate valve must be a pentode, because the effect of feed-back in this case is to make the apparent input resistance of the output stage very low. The load into which V_1 works is quite small, therefore, and this is a bad condition for a triode but a good one for a pentode. With any large amount of feed-back serious difficulty will be found in obtaining sufficient undistorted output from V_1 to drive the output stage. The circuit is normally only useful when small amounts of feed-back are wanted and it is not often used.

The most widely used of all feed-back circuits is that of Fig. 116. It is a conventional two-stage amplifier with the bypass condenser omitted from the bias resistance in the first stage, with one side of the output transformer secondary earthed, and the other side connected to the cathode of V_1 through R_3 . If R_3 is disconnected from the transformer and connected across R_2 the overall voltage amplification is A_1A_2 , where A_1 is the amplification of the first stage measured between its grid and anode and A_2 is the gain of the second stage similarly measured. There is internal current feed-back in V_1 from the cathode resistance comprising R_2 and R_3 in parallel. The gain A_1 is measured or calculated taking this into account.

When R_3 is connected to the transformer secondary as shown, the voltage amplification becomes $A_1A_2/(1 + A_1A_2n\beta)$ where $\beta = R_2/(R_3 + R_2)$ and n is the ratio of secondary/primary turns on the transformer. If the normal output resistance is R_a , the A.C. resistance of the output valve, with feed-back it becomes $R_o = R_a/(1 + A_1\mu n\beta)$.

As an example, take the same pentode as before and assume that $A_1 = 20$ and that $n = 1/40$. Since R_a is 60,000 ohms, μ is 360 and R_o is required to be 1,000 ohms, a simple sum shows that β is 0.327. The amplification A_2 is 51.5; therefore, the

NEGATIVE FEED-BACK

overall amplification with feed-back is 109.4 times. With the voltage feed-back removed it would be 1,030 times.

The values of R_2 and R_3 are chosen to fit two requirements simultaneously; they must be in the correct ratio to give the required value of β and their value in parallel must equal the bias resistance needed by V_1 . If R_c is this required value of bias resistance, then $R_3 = R_c/\beta$ and $R_2 = R_3/(1/\beta - 1)$. Continuing the above example, suppose R_c is 2,000 ohms; then R_3 must be 6,000 ohms and R_2 is 3,000 ohms, in round figures.

The first valve V_1 is often a pentode. When it is, its screen should be decoupled to cathode and not to earth, otherwise it will function as a pentode for the input voltage but a triode for the feed-back voltage. The action is complex and not readily amenable to calculation.

The frequency response of an amplifier such as that of Fig. 116 can readily be modified by including reactances in the feed-back circuit. Thus if a condenser be connected in series with R_3 its reactance will increase at low frequencies and reduce the feed-back; consequently the amplification will increase. An inductance in series with R_3 will give a rising treble characteristic.

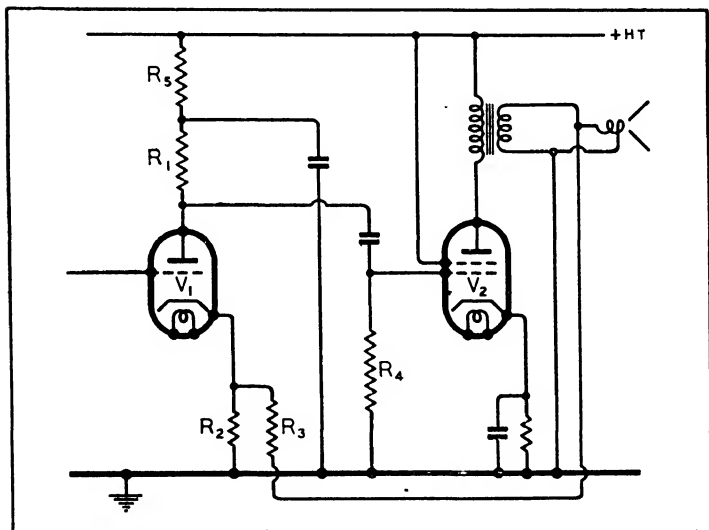

Fig. 116 : One of the most widely used feed-back circuits is shown here. It is simple and economical, and very reliable

WIRELESS SERVICING MANUAL

A condenser in shunt with R_3 will reduce its impedance at high frequencies and increase feed-back, giving a falling treble characteristic. Similarly an inductance in shunt with it will give a falling bass response.

Artifices of this nature are sometimes adopted, but they should not be used haphazardly, because the changes of gain which they cause are reflected in changes in the output impedance of the amplifier. There is always the possibility of some undesirable effects being caused thereby.

In all the circuits shown the output valve has been a pentode. This is because negative feed-back is most needed with pentodes owing to their high A.C. resistances. There is no reason why it should not be used with a triode output valve if an exceptionally low output resistance is required, but it is not usually necessary.

Roughly speaking, negative feed-back with a pentode turns it into the equivalent of a triode as far as amplification, output resistance and linearity are concerned. It may be said, therefore, why not use a triode in the first place? The answer is that the pentode does give certain advantages; in the first place, when feed-back is over two stages, the penultimate stage has to give a smaller voltage output and there is less risk of distortion at this point, and in the second place the pentode has a higher power efficiency. This means that it takes less power from the H.T. supply for a given output power.

This comparison is between an indirectly heated pentode and a directly heated triode. If the triode is indirectly heated also, as it would have to be for an AC/DC set, the pentode scores much more heavily. Indirectly heated triodes are not nearly as good as directly heated types for output valves, and the triode requires three to five times the grid bias of a pentode. In an AC/DC set the bias voltage is obtained at the expense of the anode voltage, for the H.T. voltage is fixed. A triode would therefore give a much smaller output than a pentode.

To sum up, in AC/DC sets a pentode output valve with negative feed-back is greatly superior to a triode. In A.C. sets, where there is little or no limitation on the H.T. supply there is very little to choose. The pentode with negative feed-back is slightly more efficient and has certain slight theoretical advantages, but the triode circuit is unquestionably simpler. With big A.C.-operated output stages, however, the power efficiency becomes important and then the pentode with negative feed-back is usually to be preferred. Such stages are usually push-pull, however, and usually Class "AB."

CHAPTER 26

TELEVISION RECEIVERS

WHEN television ceased at the start of the war the number of television receivers in use was small compared with the number of broadcast sets and any defects which developed were usually attended to by their makers. Nevertheless, the number of sets was increasing and when television starts again in the future the professional service-man will be called upon to tackle a new set of problems; the amateur also, in his experimental work, is liable to meet with defects which must be removed. It is felt, therefore, that some notes on the particular problems of television may be helpful, and the following remarks are based upon the author's experience with a wide variety of equipment.

Defects which may develop in equipment which has been working satisfactorily will be considered first. Their location and cure usually involve no great difficulty, for television equipment obeys the same general laws governing all wireless apparatus. Since the defects manifest themselves visually rather than aurally, however, diagnosis is rather more troublesome at first. The sound receiver needs no attention here, for any faults in it can be treated in the same way as in any other sound receiver. The vision receiver, too, is most easily attended to by connecting a pair of phones to its output, for then signals are audible and the results can be judged in the familiar way.

In general, the possible defects in the vision receiver are the same as those which may develop in any sound receiver and are treated in the same way. There are, however, certain faults which give rise to no audible sound but which have a marked effect on the picture. A fault which causes the appearance of a series of faint diagonal lines across the picture, for instance, gives rise to no audible effect in a pair of phones because the frequency of the output current responsible is well above audibility. This fault may occur in a superheterodyne and is normally due to harmonics of the intermediate frequency being fed back to the input circuits. The effect is, in fact, exactly the same as I.F. harmonic feed-back, which is dealt with in Chapter 14 for the case of broadcast receivers.

In the case of a new receiver which is being tried out, such feed-back is nearly always a sure indication that the screening is insufficient or that the filter after the detector is inadequate. The precise intermediate frequency used has also an important

WIRELESS SERVICING MANUAL

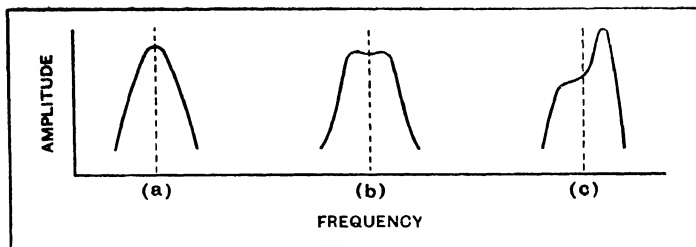

Fig. 117 : Resonance curves for different ways of tuning : (a) is for all circuits tuned to the same frequency, (b) is correct with the circuits staggered, and (c) shows incorrect adjustment

bearing on the magnitude of the effects. With a receiver which has been operating correctly, however, it may usually be taken that the appearance of this fault is a sign that a defect has developed in one of the components in the detector filter or, more likely, that a bad contact has made its appearance in some of the screening. Incidentally, it should be noted that parasitic oscillation in almost any valve is likely to give very similar symptoms.

Interference from Sound Transmitter

These diagonal lines should not be confused with the horizontal lines which may be produced by interference from the sound transmitter. This interference is usually readily distinguishable because it varies in intensity, and in the number and width of the lines, in sympathy with the sound modulation. The trouble is due to a lack of selectivity in the vision receiver or to cross-modulation in an early valve. The latter is generally caused by operating the apparatus with too large an input, but mis-alignment of the early tuned circuits towards the sound transmitter can also cause it. The defect is more likely to occur in apparatus in which the early stages are common to both sound and vision channels than in equipment having entirely separate sound and vision receivers.

The precise tuning of the R.F. and I.F. circuits as well as the setting of the oscillator condenser has a marked effect upon picture quality. With a straight set the circuits are usually very heavily damped by the input resistance of the valves, for at 45 Mc/s the electron transit time is important ; as a consequence tuning is very flat and has little effect upon the picture quality, unless a certain amount of regeneration is present. There is always some regeneration due to stray couplings, consequently

TELEVISION RECEIVERS

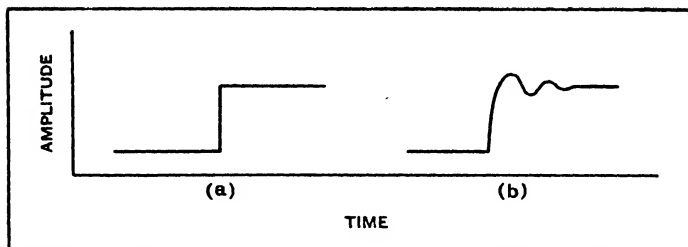

Fig. 118 : A waveform of the type shown at (a) can be distorted to the form of (b) by incorrectly-tuned circuits

one or more of the circuits may have a considerable effect upon the definition.

If the circuits are too sharp and are tuned to the same frequency, the definition will be spoiled and the picture will appear fuzzy. This effect should not be confused with the fuzziness caused by poor focusing of the light spot on the tube. In the former case the lines will be quite clear and sharp, but in the latter they too will be fuzzy or even indistinguishable.

When moderately sharp circuits are used, the usual practice is to mistune pairs of circuits slightly in opposite directions to broaden the resonance curve. When this is done, the precise settings of the trimmers are usually quite critical. It may happen, for instance, that with all circuits in tune the resonance curve has the form of Fig. 117 (a); by judicious mistuning of the circuits it can be brought to the more desirable shape shown at (b). If the mistuning is improperly carried out, however, the curve may take the form of (c), with rather a curious effect on the picture.

What is known as transient distortion usually occurs. A sudden change in current such as that shown in Fig. 118 (a) is not reproduced properly but is distorted to the form shown at (b). The visible effect is that immediately to the right of a white object there is a narrow black band followed by a white band, and then another black band and so on. The number of bands, their width and intensity, depend upon the characteristics of the receiver and upon the precise shape of the resonance curve. More than two bands are not common.

In a superheterodyne, incorrect adjustment of the R.F. or I.F. circuits will cause the same effects. The precise setting of the oscillator tuning condenser also has a considerable effect upon the picture quality, especially if the receiver is of the single-sideband type. When the control is set so that the

WIRELESS SERVICING MANUAL

carrier falls in the centre of the I.F. resonance curve the picture detail is below normal; as the control is rotated so that the carrier comes to one edge of the pass-band the definition improves and it is usually easy to find an optimum setting for picture quality. This setting usually gives about half the output obtained with the carrier on the peak of the resonance curve.

If the oscillator control is set so that the carrier falls well outside the pass-band, not only will there be a big loss of signal strength, but a peculiar form of distortion will appear. This is known as "plastic"; most of the light and shade of the picture disappears and objects acquire strong outlines, having the effect of being in relief. It is caused by an almost complete lack of the lower modulation frequencies coupled with strong reproduction of the higher frequencies.

In general, when plastic or multiple images occur in a receiver which has previously been free from these effects, it can be taken that the tuned circuits require re-alignment. It should be pointed out, however, that these effects may be caused by faults present in the signal path outside the receiver. Reflections can occur in an incorrectly terminated aerial feeder which cause similar distortion of the picture.

The trouble may also arise in the path of the signal between the transmitting and receiving aerials. The received signal may have travelled by several different paths; one may be direct, the others will be indirect and be present owing to reflection from buildings or other objects. The signals coming by the indirect paths take longer to reach the receiving aerial than those coming by a direct path and so give rise to multiple images.

The remedy lies in so arranging the aerial that it is responsive to the signal from one path only. A highly directive aerial is obviously required and it must be oriented experimentally to the optimum direction. In the author's experience, however, these external causes of multiple images do not cause much trouble at normal distances from the transmitter. It is, nevertheless, well to bear their possibility in mind when distortion is evident and it cannot be remedied by the adjustment of the receiver.

Unfamiliar Defects

The defects which, because of their unfamiliarity, are mostly likely to be troublesome, however, lie in the time-base and cathode-ray tube circuits, and here a distinction must be made between electric and electromagnetic deflection and

TELEVISION RECEIVERS

focusing, for the associated equipment is different in the two cases. With electric deflection four deflecting plates are built into the tube and deflection of the electron beam is obtained by applying voltages of saw-tooth wave-form to these plates. The horizontal plates have a voltage of 10,125 c/s applied, and the vertical deflection plates one of 50 c/s. The amplitude of the deflecting voltages is usually about 1,000 volts peak-to-peak.

If the whole illuminated area of the screen is to be evenly focused and if there is to be no interaction between the two sets of deflecting plates, it is necessary for the mean potential of each pair of plates to be constant and independent of the amplitude of the deflecting voltage. This necessitates the deflecting voltages being applied in push-pull to the plates. The conventional time-base for electric deflection thus consists of a gas-filled triode saw-tooth oscillator and a two-valve triode paraphase-type amplifier. An H.T. supply of about 1,000 volts is usually adopted.

Special Requirements

The circuits employed largely follow ordinary amplifier practice, but the frequency response and phase-shift requirements are different from those needed in a sound amplifier. The frame time-base amplifier must give negligible phase-shift over a frequency-band of about 50–500 c/s at least, while the line time-base amplifier must be good over the range of approximately 10,000–100,000 c/s. In practice the only difficulty encountered lies in obtaining an adequate response in the line amplifier, for stray capacities prove troublesome. The effect of an inadequate high frequency response is to make the fly-back time too slow and in the picture this can be seen as a cutting off of the left-hand side of the picture. In extreme cases, the left-hand side may be folded back on itself. The cause of a slow fly-back time does not necessarily lie in the time-base, but this is the first place to look and every endeavour should be made to keep the capacity of the connecting leads to the line deflecting plates at a minimum. The grid circuit of the paraphase valve is also important from this point of view. Trouble with a slow fly-back is rarely encountered in the frame deflecting circuit.

Other causes of a slow fly-back are a defective gas-triode, or more likely, serious deformation of the shape of the line synchronising pulse. This is normally due to excessive stray capacity in the circuits of the sync separator.

The output of the time-bases is coupled to the deflecting

WIRELESS SERVICING MANUAL

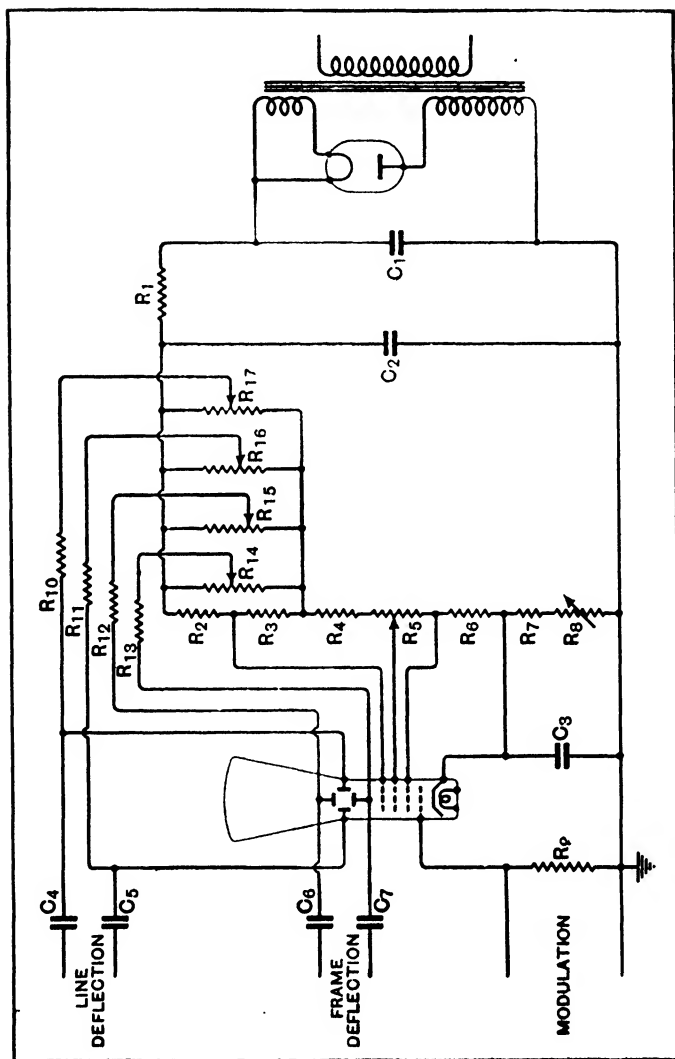

Fig. 119 : The arrangement of the high-voltage unit, focus R5, brilliance R8 and shift controls is shown here for a tube having electric focusing and deflection. R14, R15, R16 and R17 are the shift controls

TELEVISION RECEIVERS

plates by condensers and resistances exactly in the manner of an R.C. intervalve coupling. When the positive terminal of the high-voltage tube supply is earthed, the potential across these condensers is of the order of 600 volts only. When the negative terminal is earthed, however, it is some 3,000-4,000 volts.

Whatever the connections, a leak in one of these condensers will cause the position of the picture on the end of the tube to alter, for one of the plates will receive a bias voltage with respect to the one opposite it. A slight leak can be corrected by adjusting the appropriate shift control which is provided for centring the picture. Such controls operate by biasing the plates and if a leak develops its correction by this means will alter the mean potential of the deflecting plates. This will affect the focusing and it may not be possible to refocus properly by adjusting the second anode voltage. The correct thing to be done is to replace the defective condenser.

Intermittent Condenser Breakdown

Instead of, or as well as, developing a leak, a condenser may show an intermittent breakdown. When this occurs the picture will fly off the end of the tube and then come back again slowly.

A frame deflecting circuit condenser will cause a vertical movement of the picture and a line circuit condenser a horizontal movement. The speed of return of the picture depends upon the circuit values, but in the case of the frame deflection may be about 1 or 2 seconds.

The tube is usually operated at about 4,000 volts and a typical network is shown in Fig. 119. Here a half-wave rectifier valve is used with a reservoir condenser C_1 and a resistance-capacity smoothing circuit $R_1 C_2$. The condenser C_1 must be rated for working at the peak voltage of the transformer, that is, $\sqrt{2}$ times the R.M.S. transformer voltage, and the rating of C_2 should not be far short of this figure. A typical transformer may be wound for 3,000 volts, and the rating of C_1 must then be not less than 4,250 volts. During the non-conducting half-cycles the voltage across the valve may reach twice this figure, or 9,000 volts. This is the peak inverse voltage and is $2\sqrt{2}$ times the R.M.S. transformer voltage.

It is very important to notice that this voltage appears between the rectifier filament winding and one end of the high-voltage winding and a very high standard of insulation is necessary if a breakdown is to be avoided. Other arrangements of the rectifier are possible, but the peak inverse voltage always appears between some parts of the transformer with a valve

WIRELESS SERVICING MANUAL

rectifier and a negative earth to the high voltage supply. With a positive earth it is possible to avoid this voltage's appearing in the transformer, and with either a positive or negative earth it can be avoided with a metal rectifier.

After the smoothing, a potentiometer is connected across the H.T. supply and the various electrodes of the tube are fed from tappings on it. Measuring voltages with respect to cathode, the grid is made about 30–200 volts negative and the precise bias is adjustable by R8. This is the brilliancy control. The first anode is about 250–400 volts positive and the second anode about 1,000 volts positive; its potential is adjustable by R5 and is varied for focusing the light spot on the screen. The third anode potential is fixed and is some 3,000–4,000 volts positive.

The condensers and resistances C₄, C₅, C₆, C₇, R₁₀, R₁₁, R₁₂, R₁₃ are the coupling components from the time-bases to the deflecting plates. Each of the leaks is returned to a potentiometer (R₁₄, R₁₅, R₁₆, R₁₇) across the resistances R₂ and R₃ to the centre-point of which the third anode is returned. As a result, the potential of any deflector plate can be varied positively or negatively with respect to the third anode by perhaps 100–200 volts.

It is not usual to find four potentiometers connected in this way. Normally two only are used and the two other leaks are returned directly to the third anode. The two potentiometers then form the horizontal and vertical shift controls and enable the picture to be centred.

It has been found, however, that there is an optimum mean potential for each pair of plates and that this may be positive or negative with respect to the third anode. Much depends on the particular tube used, of course, but it is often possible considerably to improve the focusing, and hence the definition, by using the four controls shown in Fig. 119. In this diagram R₁₆ and R₁₇ are horizontal shift controls and R₁₄ and R₁₅ are the vertical shift controls. By altering R₁₄, the picture will move; an adjustment to R₁₅ will bring it back again to the centre. The position of the picture will then be the same as before, but the mean potential of the plates will be different and this will affect the focusing.

When adjusting a system of this type, first of all centre the raster on the tube and then focus as well as possible with R₅. The next step is to determine whether better focusing can be secured by an alteration in the mean potential of the plates and the adjustments should preferably be carried out on a picture

TELEVISION RECEIVERS

rather than with a blank raster. The reason for this is that with incorrect adjustments it is possible for the light spot to be drawn out into a line, and if this is horizontal, good focusing can be obtained as judged by the line width, but picture definition will be very poor.

Changing the Mean Plate Potential

To change the mean potential of the plates, shift the picture vertically two inches or so by R_{14} , centre it again by R_{15} , and then refocus by R_5 . If the definition has improved or the focus is more evenly maintained over the raster, try shifting the mean potential more in the same direction. On the other hand, if the results are worse it is clear that the mean potential is being changed in the wrong direction. When the best results have been obtained with R_{14} and R_{15} , the horizontal controls should be similarly treated. Do not forget to readjust R_5 every time one of the shift controls is altered.

This process is undoubtedly tedious, but it is well worth while, for it is often possible to secure a really big improvement in definition with careful adjustment.

When electromagnetic deflection and focusing are used the circuits are quite different. The tube usually contains only cathode, grid and anode, focusing and deflection being obtained by magnetic fields produced with the aid of external coils mounted around the neck of the tube. With correctly designed coils it is easier to obtain even focusing over the raster than with electric arrangements, but it is usually necessary for the focusing coil to be carefully centred so that its axis is coincident with the axis of the electrode assembly in the tube.

Focusing is accomplished by varying the current through the coil by a variable resistance. As the resistance of copper wire increases with temperature the current through the coil, and hence the focusing, tends to alter as the apparatus warms up. Normally this is not serious and if the adjustment is made with the gear at normal temperature, the correct focus is reached a few minutes after switching on.

Time-Base Output Requirement

In general, a time-base for magnetic deflection contains a saw-tooth oscillator and a pentode amplifier. The output required is in the form of a saw-tooth current wave; the valves are consequently operated at about 250 volts only but with a large standing anode current. In the case of the frame deflecting circuit, little difficulty arises, and an output valve taking

WIRELESS SERVICING MANUAL

30 mA or so can provide an adequate output to the deflecting coil, which is usually choke-capacity fed.

The line circuit is much more difficult and it is the general practice to use comparatively few turns on the deflecting coils and to feed them through a step-down transformer. Even then the output valve must take some 70 mA anode current if full deflection is to be secured.

When the input saw-tooth voltage to the line output valve has a rapid fly-back, the effect in the anode circuit is the same as if this circuit were interrupted. Consequently a high back E.M.F. is generated in the coils. Its value depends on the current and the speed of fly-back, but it can easily reach several thousand volts. This is one reason for using relatively few turns on the line deflector coils ; a moderate number of turns reduces the back E.M.F. on the coil and there is more space available for adequate insulation.

The back E.M.F. across the coil, however, is stepped up by the output transformer and a high peak voltage is applied to the anode of the output valve on the fly-back. A resistance-condenser combination is often connected across the primary of this transformer in order to limit the voltage, but even so it is necessary to watch the insulation of this circuit carefully.

In particular, the valvholder should be carefully chosen. The author met a case in which an arc developed between the anode and two other sockets ; at first it was evident only when the time-base was operating, but at length it became continuous with no input to the valve. Examination of the holder showed that a carbon track had appeared between the sockets ; it was, of course, deposited by the initial high-voltage arcing. If a fault of this nature occurs, the only thing to do is to replace the holder and to see that the new one is of a type giving a maximum clearance between the metal parts, especially the parts contacting with the surface of the insulating material.

The general arrangements of the tube circuits is shown in Fig. 120 and is obviously much simpler than the corresponding equipment for electric deflection. No smoothing is usually needed in the high voltage supply, a reservoir condenser C_1 being sufficient ; R_2 is the bias control for brilliancy. All the rest of the apparatus, including receiver and time-bases, can be run off a common supply of the order of 250-300 volts only.

Mains hum in television equipment varies in its visible effects according to its point of entry. With 50 c/s mains its effects are stationary because the frame scanning is at the same frequency. With an unsynchronised raster, however, the visible

TELEVISION RECEIVERS

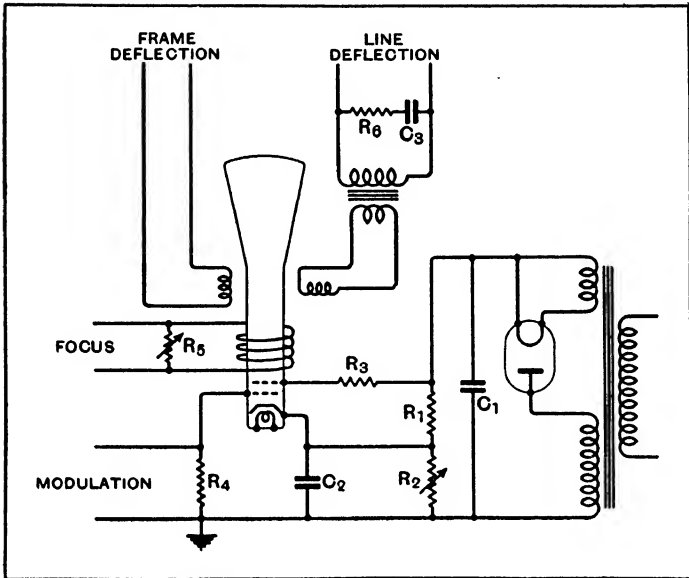

Fig. 120 : In this diagram is given a common arrangement for a tube with electromagnetic focusing and deflection. R2 is the brilliance control and R5 the focus. Shift controls are often omitted

effects of hum will be moving vertically. Excessive ripple on the H.T. supply of the line time-base causes the vertical edges of the picture to be wavy instead of straight. The effect is quite distinctive and its presence is proof that there is a ripple on the line scanning voltage or current ; the precise cause of the ripple must be found by searching in the appropriate circuits in the usual way. Hum in the frame time-base causes less distinctive visible effects ; usually, however, it upsets the interlacing. Its presence can often be detected by the possibility of locking the frame time-base at mains frequency without any sync pulse from the signal.

Hum in the tube voltage supplies or in the receiver does not affect the shape of the raster, but gives rise to a dark band across the picture. With severe hum the band may be black ; with slight hum it will be no more than a slight darkening of a portion of the picture. Hum in the receiver may also affect the frame synchronising, since it will get through the sync

WIRELESS SERVICING MANUAL

separator in some degree. Hum in the high-voltage supply, however, will rarely have any effect on the synchronising.

Synchronising troubles are not ones which are very likely to develop. When trying out an experimental receiver, of course, all sorts of faults may be found, but in equipment which has been operating correctly little is likely to go wrong. A complete failure of synchronising may occur, through the failure of the valve used for sync separation; this is easy to diagnose, but when checking its operating voltages do not forget that it is normal with some types of amplitude filter to operate a screen-grid valve with a normal screen voltage but some 6-10 volts only for the anode supply.

Those accustomed to high voltages will naturally be wary of handling the equipment when it is switched on and will remember that condensers can hold a charge for quite a long time. In the high-voltage circuits it is customary for the condensers to have high resistances across them, so that they will discharge if given time. Their discharge is quite slow, however, judged by broadcast receiver standards, and a nasty shock can be obtained if one puts one's fingers across the terminals even a minute or so after switching off. Always allow several minutes' interval before poking about in the high-voltage circuits.

High-Voltage Faults

The high-voltage supply can be responsible for some very elusive faults. The author had a case of a receiver which produced good results for some months and then started to give trouble occasionally. The trouble took the form of the appearance of bright spots on the picture, rather like car ignition interference, accompanied by poor synchronising. The trouble was intermittent, but gradually got worse, and the interior of the cabinet smelt strongly of ozone. This gave the main clue, for ozone is produced by sparking. No sign of trouble appeared in the high voltage unit, but it was at length noticed that faint sounds of sparking could be heard at the base of the tube.

Upon removing the base from the tube and switching on, the cause of the trouble was clear, for on looking into the base in the dark, bright blue spots were evident on the corners of the contacts. The trouble was caused largely by surface leakage across the bakelite and corrosion of the contacts, and these in turn were due to moisture in the atmosphere being deposited on the bakelite and metal and carrying with it various corrosive elements. The discharge, once started, made matters worse.

The remedy, of course, is to clean the tube base thoroughly

TELEVISION RECEIVERS

and to polish the contacts so that there are no sharp edges or rough parts on the metal. Any roughness greatly increases the likelihood of a discharge.

Corona may occur elsewhere in the high-voltage circuits and may persist for a long time without apparently doing any harm. Eventually, however, there is likely to be a breakdown, so that it is as well to trace the source of ozone whenever it is smelt. The most likely points of trouble are the rectifier, mains transformer, and the connections to these components; the trouble can arise in any part of the high-voltage circuits, however, where the insulation is poor or air-spacing is inadequate, especially if the metal parts are not polished and free from sharp edges.



Hunts Capacitance and Resistance Analyser

CHAPTER 27

THE USE OF CATHODE-RAY TEST GEAR

LITTLE stress has been laid on the use of the cathode-ray tube in receiver testing, for it is felt that even to-day it is not generally available. While it costs much less than it did some years ago, a good oscilloscope is still fairly expensive and it is supplementary to other apparatus. By using it one cannot escape the need for the ordinary test gear which has been frequently referred to in earlier chapters.

There is no doubt that the cathode-ray tube is essential to research and receiver design and it is almost essential to television servicing, but it is far less important for broadcast receiver servicing. This does not mean, however, that it cannot be of very great assistance in this connection. With suitable auxiliary apparatus it can be very valuable, and in cases where large numbers of receivers are dealt with its cost can readily be justified.

The main use of the oscilloscope in receiver servicing is with a "wobbly oscillator" for the visual alignment of the various tuned circuits. When I.F. transformers of the "over-coupled" variety are used this equipment provides the only simple method of adjusting them.

The usual commercial oscilloscope consists of a cathode-ray tube, amplifier, linear time-base and power supply. The output of the time-base is applied to the horizontal, or X, plates of the tube and it moves the spot steadily across the screen, usually from left to right. The fly-back is quite rapid and successive traversals of the screen coincide with one another.

The number of traversals a second is variable by the operator and the range provided is often from 2 or 3 a second to 5,000 or so. Above about ten a second the eye cannot follow the spot and there is the appearance of a line on the screen. Flicker disappears above some 30-40 traversals a second.

The waveform to be examined is applied to the vertical or Y deflecting plates. If its amplitude is insufficient for direct observation, as is often the case, an amplifier is used and is usually included within the case of the oscilloscope.

As it stands, the oscilloscope is useless for circuit alignment, for it requires certain associated equipment, but is quite suited for waveform examination. The waveform in all parts of an A.F. amplifier, for instance, can readily be examined.

The amplifier should be provided with an input of good sine waveform derived from some form of A.F. oscillator, and the

THE USE OF CATHODE-RAY TEST GEAR

input of the oscilloscope clipped in turn to each part of the amplifier which it is desired to investigate. The amplifier input should be kept constant while doing this and the desired size of trace on the tube obtained by suitably varying the gain of the oscilloscope amplifier.

If the trace departs noticeably from a sine waveform when it is known that the amplifier input is good it is a sign of serious amplitude distortion. The oscilloscope used in this way is not a very sensitive detector of amplitude distortion, and if the input is increased until the overload point of the amplifier is reached it will usually be found that audible and visible distortion occur together.

Where the oscilloscope scores over all other testing devices is the readiness with which certain types of parasitic oscillation can be detected. It sometimes happens that an amplifier may be quite stable with its normal voltages, but go into oscillation at a high frequency when the bias on one of the valves is reduced nearly to zero.

Now in operation at full output the valve is operated at this point every positive half-cycle of the input signal, with the result that parasitic oscillation occurs during part of every positive half-cycle on the valve responsible. Normally this fault is very difficult to detect, for often the only symptom is that distortion sets in at an abnormally low output.

With no input or only a small input, the amplifier will appear normal in all respects and even with full input the change of anode current is no more than would occur if the distortion were due to other causes. When an oscilloscope is used, however, the trouble is immediately evident, for instead of the trace of Fig. 121 (a) a picture such as that of (b) is obtained.

Here the valve starts to oscillate at radio-frequency when its

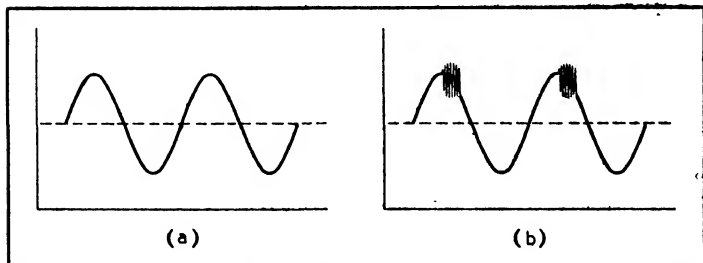

Fig. 121 : Two cycles of a sine wave are shown at (a), and at (b) the same cycles with an R.F. oscillation occurring over a portion of the positive half-cycles. This effect sometimes occurs in A.F. amplifiers

WIRELESS SERVICING MANUAL

grid potential swings to zero on the A.F. signal and continues to do so until the grid voltage falls to about half-way between zero and normal bias. Oscillation then ceases and the remainder of the A.F. cycle is dealt with properly.

When used with sine wave input voltages little difficulty is usually experienced in synchronising the time-base to give a steady image. In television work, however, difficulty is often experienced. The oscilloscope is used very largely for examining the waveform of the sync pulses in the various stages and the effectiveness of the amplitude filter. It is found in practice that sometimes there is no trouble with oscilloscope synchronising while at others there is.

The reason for this lies in the polarity of the signal applied to the oscilloscope. Most types need a voltage change in a positive direction to trigger the time-base, and when the oscilloscope is connected to a point in a television receiver at which the pulses are in this sense no difficulty is experienced. It is when the pulses are in the opposite sense that it becomes very troublesome to secure a stable trace on the tube.

It will be found, too, that the amplifier included in many oscilloscopes is not good enough for television and that it very seriously distorts line sync pulses, so that no useful results can be secured with it. The best course is to cut out the internal amplifier and to build an external one with a response up to at least 200,000 c/s and preferably higher.

Such an amplifier should be built on the lines of a television V.F. stage and television type R.F. pentodes can well be used. It is advisable also to include a phase-reversing stage so that the synchronising difficulty referred to above can readily be overcome.

A suggested arrangement is shown in Fig. 122. Here V_1 is a phase-reversing stage, for the switch S_1 permits the output to be taken from either its anode or its cathode. R_1 and R_2 should be equal and can well be 10,000 ohms when V_1 is a triode of about 4,000 ohms A.C. resistance. The gain is slightly below unity and when the output is taken from the cathode both input and output are in the same phase. Whatever the phase of the input, positive sync pulses can be applied to the oscilloscope time-base.

The valve V_2 is the amplifier and a gain of 20-30 times should be possible with a television-type R.F. pentode. Circuit values should be worked out in accordance with the usual television practice and depend largely upon the input capacity of the oscilloscope.

Every effort should be made to keep this capacity at a minimum, since for a given response R_3 is inversely proportional

THE USE OF CATHODE-RAY TEST GEAR

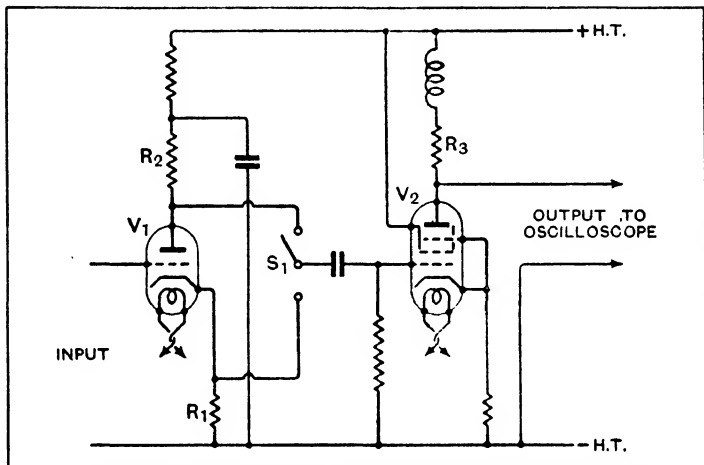

Fig. 122 : An oscilloscope amplifier suitable for television work is shown here ; V1 is a phase-reversing stage and V2 is the amplifier proper

to the total circuit capacity, and the gain and undistorted output of the amplifier are proportional to R_3 . Too high a capacity, therefore, means that R_3 must be too low for reasonable stage gain and output.

It is normally only for television servicing that such a special oscilloscope amplifier is necessary, and in the great majority of cases encountered with sound apparatus the ordinary amplifier is quite satisfactory. There is, however, one point of difficulty which is quite likely to arise when dealing with transformer-coupled A.F. amplifiers.

Most saw-tooth oscillators pass heavy grid current on the fly-back and this sets up a sharp voltage pulse at the sync input terminals. If these terminals are connected, in parallel with the deflector plates or amplifier input, to a transformer or choke in the amplifier under test this circuit will be kicked into oscillation at its natural frequency and the trace on the tube will be seriously distorted.

The effect will be absent only if the resonant circuit formed by the inductance of the transformer or choke and the circuit capacity is damped beyond a certain value. It will nearly always be found if the oscilloscope is connected to the secondary of an intervalve transformer unless that transformer has a damping resistance across its secondary.

The effect can easily be avoided, by feeding the sync terminals

WIRELESS SERVICING MANUAL

in parallel with the deflector plates from the output of the oscilloscope amplifier, so that this amplifier acts as a buffer stage between the circuit under test and the time-base. No trouble will then be encountered.

What is one of the most important uses of the oscilloscope in servicing must now be dealt with. This is its application to the visual alignment of tuned circuits. In addition to the oscilloscope a "wobbly oscillator" or "wobulator" as it is frequently termed, is needed. Actually, this is an R.F. oscillator frequency-modulated by the saw-tooth wave of the oscilloscope time-base.

The usual practice is to have an R.F. oscillator of any conventional type operating at a convenient fixed frequency—say 3 Mc/s. Across the tuned circuit of this oscillator is connected a frequency-control valve which functions in the same way as the control valve in an automatic frequency control system.

It is a valve connected so that its output impedance is chiefly a reactance, the value of which is a function of grid bias over an adequate range. By changing the bias on the valve its output reactance changes and hence the resonant frequency of the oscillator circuit with which it is in parallel. The oscillator frequency can thus be controlled by altering the grid voltage of the control valve.

This valve has applied to its grid a saw-tooth voltage wave taken from the oscilloscope time-base, so that the net result is that the oscillator frequency varies with the time-base voltage. The variation is usually about ± 30 kc/s from the mean value.

When the C.R. tube spot is on the left-hand side of the screen the oscillator frequency may be 2.97 Mc/s and it will rise steadily as the spot moves across the screen. In the middle it will be 3 Mc/s and when it has reached the right-hand side the frequency will have become 3.03 Mc/s. The fly-back then occurs; the spot rapidly goes back to the left-hand side and the frequency rapidly returns to 2.97 Mc/s. Distance horizontally becomes a measure of frequency.

If the output of this frequency-modulated oscillator is applied to the input of an amplifier tuned to the mean frequency, in this case 3 Mc/s, the D.C. detector output will vary in accordance with the gain of the amplifier at the frequency applied at any instant. It will, in fact, vary according to the overall resonance curve of the amplifier.

This direct current sets up a similarly varying voltage across the resistances of the detector circuit and if this is applied to the vertical deflector plates of the oscilloscope the position of the spot in the vertical direction will correspond to the gain of the

THE USE OF CATHODE-RAY TEST GEAR

amplifier at the frequency applied at that moment. The spot consequently traces out the resonance-curve of the amplifier.

If the process is repeated sufficiently rapidly, the resonance-curve becomes in appearance a solid line because of the retentivity of the eye, and the changes of direct voltage in the detector output can be passed through a resistance-capacity coupling. This is important, since it permits an amplifier to be used between the detector and the deflector plates, and so a reasonably large image can be secured.

As described so far, the oscillator has a fixed mean frequency and it cannot be varied directly without affecting the amount of the frequency modulation. To obtain an output at any desired mean frequency the superheterodyne principle of frequency changing is adopted.

Another unmodulated oscillator covering a wide range of frequencies is used and the outputs of the two oscillators are applied to a mixing stage—the difference frequency in the output being applied to the apparatus under test. Thus, if an output of 465 kc/s is wanted and the frequency-modulated oscillator has a mean output at 3 Mc/s, the additional oscillator is set at $3 \pm 0.465 = 2.535$ or 3.465 Mc/s.

As the “wobbly” oscillator and the horizontal sweep are both controlled from the time-base synchronism is inherent. It is, however, usually advisable to lock the time-base to the mains frequency, or a sub-multiple of it, to prevent any hum from causing a wobble on the image. In spite of the inherent synchronism the time-base frequency is quite important, and it must be chosen correctly if a distorted and misleading trace is not to be secured.

If the frequency is too high in relation to the selectivity of the amplifier serious distortion of the trace will result, the distortion occurring just beyond the peak of the resonance curve. The better the circuits used in the amplifier, the lower must be the time-base frequency and in no circumstances should it exceed 50 c/s.

The general practice is to use 25 c/s, but in some cases $12\frac{1}{2}$ c/s is better. Flicker of the image is then very noticeable, but is not a serious drawback.

If the frequency is too low in relation to the characteristics of the circuits between the detector and deflector plates, the resonance curve will again be distorted. This will take the form shown in Fig. 123 where the solid line curve indicates the correct trace of the true resonance curve and the dotted line shows the distorted trace.

This trouble is caused by an inadequate low-frequency

WIRELESS SERVICING MANUAL

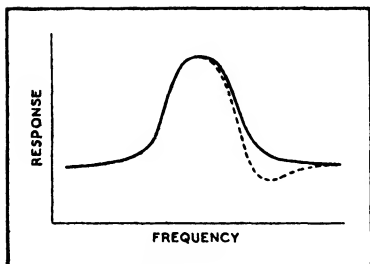

Fig. 123 : The dotted curve illustrates how the trace of a resonance curve can be distorted by an inadequate low-frequency response in the oscilloscope amplifier

response in the circuits coupling the detector to the deflector plates. When it is found it can be overcome by increasing the time-base frequency, but as this may introduce another form of distortion it is better to improve the circuits responsible.

The response in the oscilloscope circuits must be maintained down to the fundamental time-base frequency—25 c/s or 12.5 c/s,

whichever be adopted. This means that the oscilloscope amplifier must be a good one; large capacity coupling condensers must be used and particular attention paid to grid bias circuits.

Because of this effect it is rarely satisfactory to use the A.F. amplifier of the receiver and the input to the oscilloscope should be taken directly from the detector. As resistance-capacity coupling is used between the detector and the first A.F. stage in most modern sets, it is rarely necessary to disconnect anything in the receiver and it suffices to clip the oscilloscope input lead on to the detector output.

In some sets, however, choke or transformer coupling is used immediately after the detector and it is then imperative to disconnect this component if a very distorted trace is to be avoided.

When using this equipment A.V.C. should be rendered inoperative and this is usually easily done by short-circuiting one of the A.V.C. filter condensers by a lead with a crocodile clip at each end. With these precautions no difficulty should be experienced in obtaining a good trace.

Little need be said regarding the actual circuit adjustments when using cathode-ray equipment, for it is obvious that the various trimmers are adjusted for the desired shape of resonance curve combined with the maximum height of trace. It is thus quite easy to trim an amplifier with overcoupled tuned circuits, for the precise effect of every adjustment is clearly shown. In no other way can such circuits be so readily adjusted.

There are, of course, many applications of the oscilloscope beyond those mentioned here, but most of them belong more to measurement than to general servicing. Their discussion in this book would consequently be out of place.

APPENDIX I

Common Circuit Constants

Condensers

<i>Position</i>	<i>Circuit</i>	<i>Capacity</i>
Bias Resistance by-pass	R.F. or I.F.	0.1 μF
	A.F.	25-250 μF
	(old sets)	1-4 μF
Grid Circuit Decoupling	R.F. or I.F.	0.05-0.1 μF
	A.F.	0.5-1 μF
Screen-grid Circuit Decoupling	R.F. or I.F.	0.1 μF
	A.F.	0.5-4 μF
Anode Circuit Decoupling	R.F. or I.F.	0.1-1 μF
	A.F.	0.5-8 μF
Inter-stage Coupling	R.F.	100-1,000 $\mu\mu\text{F}$
	Grid Detector	100-300 $\mu\mu\text{F}$
	A.F.	0.01-0.1 μF
R.C.-fed Transformer Anode by-pass	A.F.	0.1-2 μF
	Grid Detector Anode Bend Detector	100-2,000 $\mu\mu\text{F}$ 100-200 $\mu\mu\text{F}$
Load Resistance by-pass	Diode Detector	100-300 $\mu\mu\text{F}$
R.F. Filter	Diode Detector	100-500 $\mu\mu\text{F}$
Output Feed	Choke Output	1-4 μF
Reservoir Condenser	A.C. Sets	4 μF
	Universal	4-32 μF
Smoothing Condensers	A.C. or D.C.	4-8 μF
Band-Pass Filter Coupling	" Bottom-End "	0.01-0.05 μF
	" Top-End "	0.5-2 $\mu\mu\text{F}$
Tuning	M.W. and L.W. bands	500 $\mu\mu\text{F}$
	All-wave	350 $\mu\mu\text{F}$
	Short-wave	100-200 $\mu\mu\text{F}$
Reaction	M.W. and L.W.	100-500 $\mu\mu\text{F}$
	All-wave	100-300 $\mu\mu\text{F}$
	Short-wave	100-200 $\mu\mu\text{F}$
Earth Lead Isolating Condensers	D.C. Sets	1-2 μF
	Universal	0.1 μF (max.)
Aerial Lead Isolating Condensers	D.C. Sets	0.001-0.1 μF
	Universal	0.001-0.01 μF (max.)
Mains Aerial	—	100-200 $\mu\mu\text{F}$
Mains to Earth	A.C. and Universal	0.001-0.01 μF (max.)
	D.C.	0.001-4 μF
Valve Heater to Earth	A.C. sets ; M.W. and L.W.	0.1 μF
	S.W.	0.01 μF

WIRELESS SERVICING MANUAL

Resistances

<i>Position</i>	<i>Circuit</i>	<i>Value</i>
Bias Resistance	S.G. or R.F. Pentode	50-500 Ω
	A.F. Triode	500-2,000 Ω
	Output Triode	500-1,000 Ω
	Output Pentode	145-500 Ω
	Anode Bend Detector	2,000-10,000 Ω
Grid-circuit Decoupling	R.F. or I.F.	20,000-500,000 Ω
	A.F.	50,000-250,000 Ω
Screen-circuit Decoupling	R.F. or I.F.	100-1,000 Ω
	A.F.	2,000-10,000 Ω
Anode Circuit Decoupling	R.F. or I.F.	500-10,000 Ω
	A.F.	5,000-100,000 Ω
Anode Coupling	A.F.	10,000-100,000 Ω
	Grid Detector	20,000-50,000 Ω
	Anode Bend Detector	0.1-0.25 M Ω
Grid Leak	R.F. or I.F.	1-2 M Ω
	Grid Detector	0.1-5 M Ω
	A.F.	0.1-1 M Ω
Load Resistance	Diode Detector	0.1-0.5 M Ω
Volume Control	Bias on V.M. Valve (1)	10,000-20,000 Ω
	A.F. Potentiometer	0.1-1 M Ω
Tone Control	A.F.	0.1-1 M Ω
Grid Stopping (Anti-Parasitic)	R.F.	20-200 Ω
	F.C.	20-500 Ω
	I.F.	100-500 Ω
	A.F.	1,000-10,000 Ω
Anode Stopping (Anti-Parasitic)	R.F. or I.F.	100-500 Ω
	A.F.	50-100 Ω

The D.C. Resistance of Coils and Chokes

<i>Component</i>	<i>Circuit</i>	<i>Resistance</i>	
Tuning Coil	M.W.	1-5 Ω	
	L.W.	5-50 Ω	
Transformers	I.F.	5-100 Ω	
	A.F., Primary	Secondary	500-2,000 Ω
		Class "B," Primary	2,000-20,000 Ω
	Secondary	Primary	500-2,000 Ω
		Secondary	100-500 Ω
	Output, Primary	Primary	200-500 Ω
Secondary		0.05-20 Ω	
Mains Transformers	Primary	20-150 Ω	
	H.T. Secondary	100-500 Ω	
Chokes	R.F.	200-1,000 Ω	
	R.F., S.W.	20-100 Ω	
	Smoothing, 1st Stage	1st Stage	100-300 Ω
		2nd Stage	200-1,000 Ω
Speaker Field	Series fed	1,000-2,500 Ω	
	Shunt fed	2,500-7,500 Ω	

STANDARD SYMBOLS

Standard Symbols

Capacity. Symbol C. Unit, farad.

μF or mfd. = microfarad = one-millionth of a farad.

$\mu\mu\text{F}$ or mmfd. = micro-microfarad = one-millionth of a microfarad, also pF (often pronounced "puff"!) = pico-farad = $\mu\mu\text{F}$. (Some Continental components have capacity expressed in centimetres. 1 cm. = 1.1 $\mu\mu\text{F}$.)

Inductance. Symbol L. Unit, henry.

H = henry.

mH = millihenry = one-thousandth of a henry.

μH = microhenry = one-millionth of a henry.

Resistance. Symbol R. Unit, ohm.

Ω = ohm.

k Ω = kilo-ohm = one thousand ohms.

M Ω = megohm = one million ohms.

Frequency. Symbol f. Unit, cycles per second

\sim or c/s = cycles per second.

kc/s = kilocycles per second (i.e. thousands of c/s).

Mc/s = megacycles per second (i.e. millions of c/s).

$\omega = 2\pi f = 6.28 f$.

Voltage, Current and Power

V = volt.

mV = millivolt = one-thousandth of a volt

μV = microvolt = one-millionth of a volt.

A = ampere.

mA = milliampere = one-thousandth of an ampere.

μA = microampere = one-millionth of an ampere.

W = watts = product of volts and amperes (in a resistive circuit).

mW = Milliwatt = one-thousandth of a watt.

μW = Microwatt = one-millionth of a watt.

Volt-Amp = product of volts and amperes (only equals power in a resistive circuit).

kVA (usually KVA) = kilo-volt-amperes.

Various

$Q = \omega L/R$ = ratio of reactance to resistance of a coil. It is a measure of its "goodness" and is sometimes called the magnification and denoted by the letter m.

$R_D = \omega^2 L^2/R = \omega LQ$ = dynamic resistance of a tuned circuit.

DB or db = decibel. It is defined as ten times the logarithm of the ratio of two powers, or twenty times the logarithm of the ratio of two voltages or currents, both voltages or currents appearing in the same value of resistance. It is also commonly used to express voltage amplification by taking twenty times the ratio of the output to input voltages irrespective of the circuit impedances. While this usage does not conform to the proper definition given above, it is common practice.

WIRELESS SERVICING MANUAL

Valves

μ or m = amplification factor = dV_a/dV_g ,

R_a = internal A.C. resistance (ohms) = dV_a/dI_a ,

g = mutual conductance (A/V) = $dI_a/dV_g = \mu/R_a$,

where dV_a , dV_g , dI_a are a change of anode volts, grid volts, and anode current respectively, and current is expressed in amperes.

Mutual conductance is usually measured in milliamperes per volt (written mA/V) or microamperes per volt (μ A/V). It is sometimes expressed in the conductance term mho (the mho is the reciprocal of the ohm). 1 micromho is equal to 1 μ A/V.

I_a = anode current.

V_a = anode voltage.

I_g = grid current.

V_g = grid voltage.

I_{sg} = screen current.

V_{sg} = screen voltage.

I_f = filament current.

V_f = filament voltage.

I_c = cathode current.

V_c = cathode voltage.

Reactance and Impedance. Units, ohms.

X = reactance.

X_L = inductive reactance.

X_C = capacitive reactance.

Z = impedance = combination of resistance and reactance.

Y = $1/Z$ = admittance.

G = $1/R$ = conductance.

S (sometimes B) = $1/X$ = susceptance.

Amplifiers

Class "A." Valves operated with a grid voltage about half-way between zero and the value needed to give anode current cut-off. No grid current flows during operation.

Class "AB" Push-pull stage with bias intermediate between the Class "A" and Class "B" conditions.

Class "B" Push pull stage with grid bias near the current cut-off point.

(Subscripts "1" and "2" are commonly used with the above designations; "1" indicates that grid current is not permitted, while "2" denotes that the stage is driven into grid current.)

Q.P.P. A Class "AB₁" or Class "B₁" stage.

Useful Formulae

Resonance frequency of any low-resistance circuit

$$f = 1/6.28 \sqrt{LC} \quad (L \text{ in } H, C \text{ in } F)$$

$$f = 1,000/6.28 \sqrt{LC} \quad (L \text{ in } \mu H, C \text{ in } \mu\mu F)$$

Wavelength $\lambda = 1,885 \sqrt{LC}$ (L in μH , C in μF)

and $f = 3 \times 10^8/\lambda$ (f in c/s, λ in metres)

$$f = 300/\lambda \quad (f \text{ in } Mc/s, \lambda \text{ in metres})$$

Ohm's Law $V = IR, I = V/R, R = V/I$

in volts, amperes and ohms.

USEFUL FORMULÆ

Reactance of a coil

$$X_L = \omega L = 6.28 fL$$

(f and L in c/s and H
or Mc/s and μH)

Reactance of a condenser

$$X_C = -1/\omega C = -1/6.28 fC$$

(f and C in c/s and F)

$$X_C = -10^6/6.28 fC \text{ (f and C in Mc/s and } \mu\mu F)$$

Resistances in Series

$$R_T = R_1 + R_2 + \dots$$

Resistances in Parallel

$$1/R_T = 1/R_1 + 1/R_2 + \dots$$

Sum of Reactance and Resistance

$$Z = \sqrt{R^2 + X^2}$$

Condensers in Series

$$1/C_T = 1/C_1 + 1/C_2 + \dots$$

Condensers in Parallel

$$C_T = C_1 + C_2 + \dots$$

The peak value of alternating voltage or current (of sine waveform) is $\sqrt{2} = 1.414$ times the R.M.S. value. In computing power or volt-amps, R.M.S. values must always be taken. Unless a voltage or current is definitely stated to be a peak value, an R.M.S. value should always be assumed. Thus in dealing with A.C. circuits, the statement that a valve heater, for instance, must be operated at 4 volts means 4 volts R.M.S., not 4 volts peak, for 4 volts peak is only 2.828 volts R.M.S.

The above ratio for peak to R.M.S. values is true only for sine waves, and is different for other waveforms. Thus, take the case of a modulated carrier. The carrier is usually expressed in R.M.S. volts and the modulation depth as a percentage. A carrier of 1 volt when unmodulated has a peak value of 1.414 volts and during 100 per cent. modulation it rises to 2.828 volts peak.

Valve Operating Conditions

Given the operating conditions for one anode voltage V_1 , to determine the correct conditions for a different voltage V_2 —

- (a) Multiply all voltages by the voltage factor (V_2/V_1)
- (b) Multiply all currents by the current factor $(V_2/V_1)^{3/2}$
- (c) Multiply mutual conductance by the factor $(V_2/V_1)^{1/2}$
- (d) Multiply the power output by the factor $(V_2/V_1)^{5/2}$

(This rule holds approximately for voltage changes not exceeding 2.5 : 1.)

WIRELESS SERVICING MANUAL

Superheterodyne Ganging

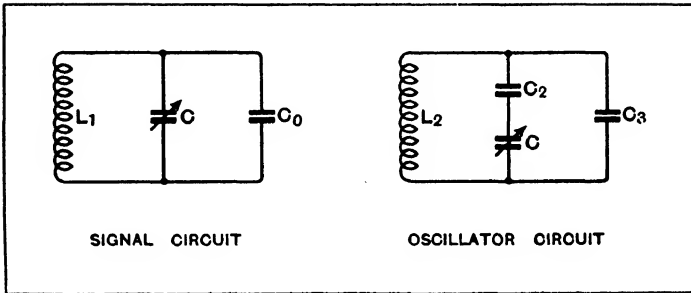

- C_0 = Signal circuit stray capacity including trimmer.
- L_1 = Signal circuit inductance.
- C_2 = Oscillator padding capacity.
- C_3 = Oscillator circuit stray capacity including trimmer.
- C_4 = Any shunt capacity across the oscillator variable condenser.
- L_2 = Oscillator circuit inductance.

Let f_{min} and f_{max} be the minimum and maximum signal frequencies to which it is required to tune and C_{min} and C_{max} be the minimum and maximum capacities of the tuning condenser.

Then

$$C_0 = C_{min} \frac{\frac{C_{max}}{C_{min}} - \frac{f_{max}^2}{f_{min}^2}}{\frac{f_{max}^2}{f_{min}^2} - 1} \quad (1)$$

$$L_1 = \frac{10^8}{\omega_{max}^2 (C_0 + C_{min})} = \frac{10^8}{\omega_{min}^2 (C_0 + C_{max})} \quad (2)$$

Next determine the three frequencies at which the ganging is to be perfect (i.e., the ganging frequencies) as follows:—

Let f' , f'' and f''' be these frequencies, and enumerate

$$F = f_{max} - f_{min} \quad (3)$$

$$f_2 = f_{min} + F/4 \quad (4)$$

$$f_3 = f_{max} - F/4 \quad (5)$$

Let f_1 = intermediate frequency.

SUPERHETERODYNE GANGING

Calculate

$$y_1 = F \frac{1.25 - \frac{1}{4} \cdot \frac{f_3 + f_1}{f_2 + f_1}}{10.66 \frac{f_2 + f_1}{f_{\min} + f_1} + 3.33} \quad (6)$$

$$y_3 = F \frac{0.75 + \frac{1}{4} \cdot \frac{f_3 + f_1}{f_2 + f_1}}{10.66 \frac{f_3 + f_1}{f_{\max} + f_1} + 3.33} \quad (7)$$

$$y_2 = \frac{F}{16} \cdot \frac{F}{f_2 + f_1} + \frac{y_3 - y_1}{3} \quad (8)$$

Then $f' = f_{\min} + y_1$ (9)

$$f'' = \frac{f_{\min} + f_{\max}}{2} - y_2 \quad (10)$$

$$f''' = f_{\max} - y_3 \quad (11)$$

The maximum ganging error is given by

$$\Delta f = f_1 \left(\frac{f_3 - f_2}{f_3 + f_2} \right)^3 \frac{1 + \frac{f_1}{f_2 + f_3}}{\left(1 + \frac{2f_1}{f_2 + f_3} \right)^2} \quad (12)$$

Now evaluate the oscillator frequencies corresponding to the signal frequencies :—

$$\left. \begin{aligned} f_o' &= f' + f_1 \\ f_o'' &= f'' + f_1 \\ f_o''' &= f''' + f_1 \end{aligned} \right\} (13)$$

Writing ω' for $6.28f'$, ω_o' for $6.28f_o'$, etc.

Evaluate

$$\left. \begin{aligned} \alpha &= 1/\omega'''^2 & \delta &= 1/\omega_o'''^2 \\ \beta &= 1/\omega''^2 & \epsilon &= 1/\omega_o''^2 \\ \gamma &= 1/\omega'^2 & \eta &= 1/\omega_o'^2 \end{aligned} \right\} (14)$$

$$\theta = \frac{\epsilon - \delta}{\eta - \epsilon} \quad (15)$$

WIRELESS SERVICING MANUAL

The next step is to evaluate the capacities in the tuning condenser corresponding to the ganging frequencies, and add on C_4 .

$$\left. \begin{aligned} C''' &= \frac{\alpha}{L_1} 10^8 - C_0 + C_4 \\ C'' &= \frac{\beta}{L_1} 10^8 - C_0 + C_4 \\ C' &= \frac{\gamma}{L_1} 10^8 - C_0 + C_4 \end{aligned} \right\} (16)$$

$$\text{Then } C_2 = \frac{C''(\theta C''' + C') - C' C'''(1 + \theta)}{C''' + \theta C' - C''(1 + \theta)} \quad (17)$$

$$L_2 = \frac{(C_2 + C')(C_2 + C''')(\eta - \delta)}{C_2^2(C' - C''')} 10^8 \quad (18)$$

$$C_3 = \frac{\delta}{L_2} 10^8 - \frac{C_2 C'''}{C_2 + C'''} \quad (19)$$

In these equations frequency is in Mc/s, inductance in μH and capacity in $\mu\mu\text{F}$.

NOTE.—When evaluating (17) slide-rule accuracy is not sufficient, for the denominator involves the difference of two quantities which are nearly equal.

As an example, suppose $f_{\min} = 0.55$ Mc/s, $f_{\max} = 1.5$ Mc/s, $f_1 = 0.45$ Mc/s, $C_{\min} = 15 \mu\mu\text{F}$ and $C_{\max} = 500 \mu\mu\text{F}$.

From (1)	$C_0 = 60.2 \mu\mu\text{F}$.	
(2)	$L_1 = 149.5 \mu\text{H}$.	
(3)	$F = 0.95$ Mc/s	
(4)	$f_2 = 0.7875$ Mc/s	
(5)	$f_3 = 1.2625$ Mc/s	
(6)	$y_1 = 0.052$ Mc/s	
(7)	$y_2 = 0.0822$ Mc/s	
(8)	$y_3 = 0.0556$ Mc/s	
(9)	$f' = 0.602$ Mc/s	
(10)	$f'' = 0.969$ Mc/s	} the ganging frequencies.
(11)	$f''' = 1.418$ Mc/s	
(12)	$\Delta f = 0.0033$ Mc/s = 3.3 kc/s., the maximum ganging error.	
(13)	$\left\{ \begin{aligned} f_0' &= 1.052 \text{ Mc/s} \\ f_0'' &= 1.419 \text{ Mc/s} \\ f_0''' &= 1.868 \text{ Mc/s} \end{aligned} \right.$	
(14)	$\left\{ \begin{aligned} \alpha &= 0.01265 \\ \beta &= 0.02755 \\ \gamma &= 0.07 \end{aligned} \right.$	$\delta = 0.00727$
(15)	$\theta = 0.52$	$\epsilon = 0.01264$ $\eta = 0.02295$

SHORT-WAVE AERIALS

$$\begin{aligned} \text{From (16)} \quad & \begin{cases} C''' = 24.3 \mu\mu\text{F.} \\ C'' = 123.8 \mu\mu\text{F.} \\ C' = 407.8 \mu\mu\text{F.} \end{cases} \\ (17) \quad & C_3 = 767 \mu\mu\text{F.} \\ (18) \quad & L_3 = 65 \mu\text{H.} \\ (19) \quad & C_3 = 88.45 \mu\mu\text{F.} \end{aligned}$$

If $C_4 = 10 \mu\mu\text{F.}$ then

$$\text{From (16)} \quad \begin{cases} C''' = 34.3 \mu\mu\text{F.} \\ C'' = 133.8 \mu\mu\text{F.} \\ C' = 417.8 \mu\mu\text{F.} \end{cases}$$

Short-Wave Aerials and Feeders

$$\begin{aligned} \text{Length of half-wave aerial in metres} &= 0.475 \lambda = 142.5/f \\ \text{in feet} &= 1.56 \lambda = 468/f \end{aligned}$$

Length of quarter-wave matching section is one-half of that of a half-wave aerial.

A reflector should be 0.485λ long and mounted 0.25λ behind the aerial.

$$\lambda = \text{wavelength (metres)} \quad f = \text{frequency (Mc/s)}$$

Impedance of twin wire feeder or $\lambda/4$ matching section

$$Z = 276 \log \frac{\text{wire radius}}{\text{wire spacing}}$$

Impedance of concentric feeder

$$Z = 138 \log \frac{\text{inside diameter of outer conductor}}{\text{outside diameter of inner conductor}}$$

A quarter-wave matching section must have an impedance

$$Z = \sqrt{Z_a Z_f}$$

where Z_a is the aerial impedance and Z_f is the feeder impedance.

WIRELESS SERVICING MANUAL

Copper Wire Tables

Bare Copper Wire

S.W.G.	Diameter	Section Area	Ohms per 1,000 yds.	Length per ohm	Weight per 1,000 yds.	Current Rating at 1,000 amps per sq. in.
	in.	sq. in.		yds.	lb.	amps.
10	0.128	0.02186	1.87	535	148.8	12.9
12	0.104	0.00840	2.83	353	98.2	8.5
14	0.08	0.00503	4.78	208	58.1	5.0
16	0.064	0.00322	7.46	135	37.2	3.2
18	0.048	0.00180	13.27	53	20.9	1.8
20	0.036	0.00102	23.6	42.4	11.8	1.0
22	0.028	0.000616	39.0	25.6	7.12	0.61
24	0.022	0.000380	63.2	15.8	4.4	0.38
26	0.018	0.000254	94.3	10.6	2.94	0.25
28	0.0148	0.000172	139.5	7.18	1.99	0.17
30	0.0124	0.000121	199	5.03	1.40	0.12
32	0.0108	0.000091	262	3.82	1.06	0.09
34	0.0092	0.000066	361	2.77	0.77	0.07
36	0.0076	0.000045	529	1.89	0.52	0.05
38	0.006	0.000028	849	1.18	0.33	0.03
40	0.0048	0.000018	1,326	27.15	3.35	18.0
42	0.0040	0.000012	1,910	18.87	2.32	12.6
44	0.0032	0.000008	2,985	10.77	1.49	8.0
45	0.0028	0.000006	3,899	9.24	1.14	6.0
46	0.0024	0.000004	5,307	6.78	0.83	4.5
47	0.0020	0.000003	7,642	4.71	0.581	3.1
48	0.0016	0.000002	11,041	3.02	0.372	2.0
49	0.0012	0.000001	21,230	1.70	0.209	1.1

Enamelled Copper				Eureka Wire	
S.W.G.	Turns per inch	Weight per 1,000 yds.	Yards per lb.	Ohms per 1,000 yds.	Ohms per lb.
		lb.			
16	14.8	37.8	26.4	209.4	5.63
18	19.7	21.3	46.9	371.8	17.76
20	26.1	12.0	83.3	661.3	56.18
22	33.3	7.3	137	1,093	153.51
24	42.1	4.52	221	1,770	403.00
26	50.6	3.03	330	2,645	899.05
28	61.4	2.05	488	3,014	1,068
30	73.3	1.44	694	5,575	3,085
32	87	1.09	915	7,350	6,940
34	98	0.832	1,202	10,128	13,174
36	116	0.543	1,840	14,840	28,272
38	143	0.340	2,810	23,808	72,764
		oz.	per oz.		
40	180	3.49	286		11,103
42	217	2.43	411		23,013
44	270	1.56	642		56,226
45	303	1.105	835		95,404
46	357	0.885	1,128		176,094
47		0.613	1,630		368,946

COPPER WIRE TABLES

Insulated Wire

Single Cotton Covered				Double Cotton Covered		
S.W.G.	Turns per inch	Weight per 1,000 yds.	Yards per lb.	Turns per inch	Weight per 1,000 yds.	Yards per lb.
		lb.			lb.	
16	14.1	38.3	26.1	13.3	38.9	25.6
18	18.3	21.6	46.3	17.3	22.0	45.4
20	24.1	12.24	81.7	21.7	12.6	79.2
22	29.8	7.48	134	26.3	7.76	129
24	37.0	4.57	219	31.3	4.92	203
26	43.5	3.21	311	35.7	3.40	294
28	50.5	2.21	452	40.2	2.37	422
30	57.5	1.58	634	44.7	1.70	587
32	63.3	1.20	835	50.5	1.32	755
34	70.5	0.781	1,280	54.9	0.977	1,024
36	86.2	0.619	1,610	64.1	0.677	1,477
38	100.0	0.392	2,550	71.4	0.437	2,287
40	112.5	0.255	3,910	78.1	0.290	3,456

Single Silk Covered				Double Silk Covered		
16	15	37.9	26.4	14.7	38.3	26.1
18	20	21.3	46.8	19.6	21.6	46.3
20	26.3	12.0	85.3	25.3	12.1	82.5
22	33.3	7.3	137	31.8	7.44	134
24	42.1	4.5	222	40	4.59	218
26	50.6	3.02	332	47.6	3.08	325
28	60.4	2.05	488	56.2	2.09	478
30	72.0	1.44	695	67.1	1.48	675
32	81.3	1.10	912	75.2	1.13	887
34	93.4	0.80	1,250	85.5	0.82	1,220
36	110	0.551	1,815	102	0.57	1,730
38	133	0.348	2,871	121	0.37	2,760
		oz.	per oz.		oz.	per oz.
40	159	3.62	276	142	3.88	258
42	192	2.58	387	161	2.80	358
44	227	1.67	599	185	1.86	536
45	250	1.33	752	200	1.48	675
46	278	1.00	1,000	217	1.15	871
47	312	0.727	1,375	238	0.845	1,190

APPENDIX II

British Colour Codes

NOTE: The standards tabulated in this section are those recommended by the Radio Component Manufacturers' Federation.

Resistance Colour Code

Figure	Colour	Figure	Colour
0	Black	5	Green
1	Brown	6	Blue
2	Red	7	Violet
3	Orange	8	Grey
4	Yellow	9	White

Tolerance Code

± 5 per cent.	Gold
± 10 per cent.	Silver
± 20 per cent.	No colour

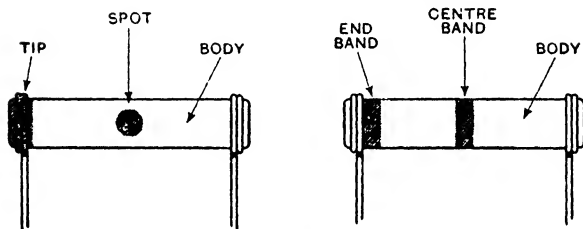

Two distinct systems of marking are used. In the older system illustrated above, the colour of the body represents the first figure of the resistance value, and the colour of the tip or end-band represents the second figure. The colour of the spot or centre-band indicates the number of ciphers following the first two figures.

In the new method illustrated below there are four bands placed towards one end of the resistance. The colours of bands 1 and 2 gives respectively the first and second figures of the resistance value, and band 3 indicates the number of ciphers following them. Band 4 represents the resistance tolerance.



Examples :

Old system. Red body, green tip, yellow spot = 250,000 ohms.

New system. Red (1), green (2), yellow (3) = 250,000 ohms.

COLOUR CODES

Colour Code for Wander Plugs (Batteries)

Highest positive H.T.	Red
2nd highest ,,	Yellow
3rd ,,	Green
4th ,,	Blue
L.T. positive	Pink
Negative (- L.T., - H.T., + G.B.)	Black
Maximum G.B. negative	Brown
2nd	Grey
3rd	White

Any additional battery lead is Violet, and any centre-tap White.

Colour Code for Fuses

60 mA	Black	1 Amp.	Dark Blue
100 mA	Grey	1.5 Amp.	Light Blue
150 mA	Red	2 Amp.	Purple
250 mA	Brown	3 Amp.	White
500 mA	Yellow	5 Amp.	Black and White
750 mA	Green		

Fixed Condenser Markings

Connecting leads for multiple blocks

Highest capacity, positive	Red
2nd highest capacity, ,,	Yellow
3rd ,,	Green
4th ,,	Blue
5th ,,	Violet
Principal negative lead	Black
2nd	Brown
3rd	Grey
Centre lead of voltage doubler condensers	White

Where two capacities are of the same value, the one of higher voltage rating has the higher colour in the table.

Common positive junctions are marked	+
Common negative junctions are marked	-
Series connections are marked	±
Unconnected sections are marked	&

Thus

8 + 8	denotes two 8 μ F condensers with common positive terminal
8 - 8 negative ..
8 ± 8 a series voltage-doubler connection
8 & 8 two isolated 8 μ F condensers

WIRELESS SERVICING MANUAL

Mains Transformer Colour Code

The leads for the high voltage secondary in the case of a Westinghouse metal rectifier or a valve half-wave rectifier are coloured red and red-yellow.

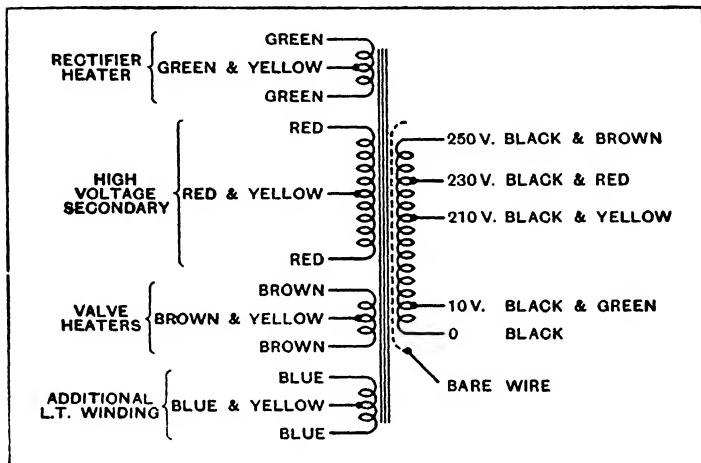

American Colour Codes

Resistances. Same as British Code.

Fixed Condensers

The code is similar to that for resistances, the figures represented by the colours being the same. Capacity is expressed in micro-microfarads ($\mu\mu\text{F}$) and three coloured dots appear on the trademark side of the condenser case. They are read from left to right, the first dot representing the first figure, the second dot the second figure, and the third the number of cyphers. Thus, three dots in order red, black, brown, represents $200 \mu\mu\text{F} = 0.0002 \mu\text{F}$, and brown, black, red, represents $1,000 \mu\mu\text{F} = 0.001 \mu\text{F}$.

When three significant figures are required to express the capacity, only the first two dots on the trademark side are coloured, the third being left blank, and the remainder of the code appears on the reverse side. The left-hand dot on the reverse side indicates the third figure and the right-hand dot the number of cyphers. Thus, a condenser having brown and violet on the trademark side, with green and brown on the other, would have a capacity of $1,750 \mu\mu\text{F} = 0.00175 \mu\text{F}$.

COLOUR CODES

Colour Code for Battery Connections

Highest positive H.T.	(+ B max.)	Red
2nd highest positive H.T.	(+ B int.)	Maroon and Red
3rd " " "	(+ B det.)	Maroon
Negative H.T.	(- B)	Black with Red tracer
Positive L.T.	(+ A)	Yellow
Negative L.T.	(- A)	Black with Yellow tracer
Positive G.B.	(+ C)	Green
Maximum negative G.B.	(- C max.)	Black with Green tracer
2nd negative G.B.	(- C low)	Black and Green
Loudspeaker (high potential lead)		Brown
" (low " ")		Black with Brown tracer

Moving-Coil Loud Speakers

Outside of output transformer primary	..	Green
Inside " " "	..	Brown
Centre-tap on " " "	..	Red
Outside of " " secondary		White
Inside " " "	..	Maroon
Outside of 1st field winding	..	Yellow
Inside " " "	..	Black
Tap on " " "	..	Grey
Outside of 2nd " " "	..	Grey
Inside " " "	..	Blue

NOTE.—Of the colour codes listed in this Appendix, that for resistances is almost universally employed. The condenser code is less widely used. The fuse code is used, but there are exceptions, particularly with fuses not intended primarily for radio purposes.

The codes for wander plugs, battery connections, mains transformers and loudspeakers are rarely used, and unless one knows that it is a given manufacturer's practice to employ them, they should not be relied upon for identifying leads.

APPENDIX III

Capacity and Resistance Bridge

A Wireless World Wide-Range Testing Set

THERE is no doubt that the best method of measuring capacity is by means of a bridge. This is a comparison method by which the unknown condenser is compared with another of known value, and the accuracy depends upon how closely the relative values of the two can be determined and upon how accurately the capacity of the standard is known. The basic circuit is shown in Fig. 1, and it is easy to see that if the reactances of C_1 and C_2 are the same and R_1 equals R_2 there will be no current through the telephones. If R_1 does not equal R_2 , however, there will be a difference of potential between the two sides of the phones and, consequently, an audible note in them. As the slider of the potentiometer is moved, therefore, the strength of the sound in the phones will vary and at the exact balance point when R_1 equals R_2 will disappear.

It is not, of course, necessary for the two capacities to be equal, but if they are not equal the balance point will be different. The balance point is connected with the relative values of the condensers by a very simple relation: $R_1 : 1/\omega C_2 :: R_2 : 1/\omega C_1$. Consequently $R_1/R_2 = C_1/C_2$. If one of the condensers, say C_2 , has an accurately known value, and the resistances can be accurately measured each time a balance has been obtained, the unknown capacity is readily calculated and is $C_1 = R_1 C_2/R_2$. This is naturally inconvenient for general use, but it is easily possible to provide a scale giving a direct calibration in capacity, and the operation of measuring capacity then becomes no more than connecting the condenser to the terminals, adjusting the control knob to give the balance, and reading off the capacity directly from the scale.

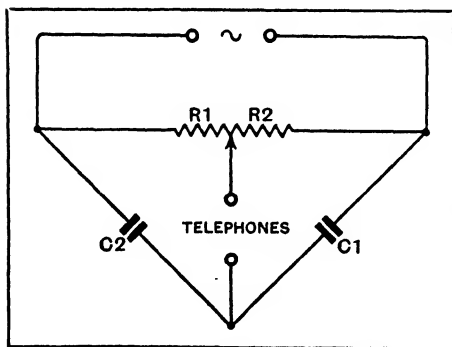

Fig. 1 : The basic circuit of a capacity bridge

In theory it is possible to measure all capacities from zero to infinity in a single range, but this is hardly possible in practice with ordinary potentiometers, for the scale would become extremely cramped at the ends. With only two ranges, however, it is easy to measure any capacity between $10 \mu\mu\text{F}$ and $10 \mu\text{F}$.

The same bridge may be used also for

CAPACITY AND RESISTANCE BRIDGE

the measurement of resistance if the standard condenser be replaced by a standard resistance, and if the values be suitably chosen the same scale and calibration hold for both resistance and capacity measurement. This has been done in the bridge described in this article, and two ranges are provided. On one range resistances of 10 ohms to 100,000 ohms can be measured, and capacities of $10 \mu\mu\text{F}$ to $100,000 \mu\mu\text{F}$ ($0.1 \mu\text{F}$), while on the other scale the reading is multiplied by 100 and so gives a range of 1,000 ohms to 10,000,000 ohms ($10 \text{ M}\Omega$) or $1,000 \mu\mu\text{F}$ ($0.001 \mu\text{F}$) to $10,000,000 \mu\mu\text{F}$ ($10 \mu\text{F}$).

The complete circuit diagram of the bridge is shown in Fig. 2, and it will be seen that the control consists of a 20,000-ohm potentiometer R_5 . The switch S_3 changes over the connections for capacity or resistance measurements, and the switch S_2 changes the range. There are two resistance standards, R_3 and R_4 , of 1,000 ohms and 100,000 ohms respectively, and two capacity standards, C_4 and C_3 , of $0.001 \mu\text{F}$ and $0.1 \mu\text{F}$ respectively. The values of these com-

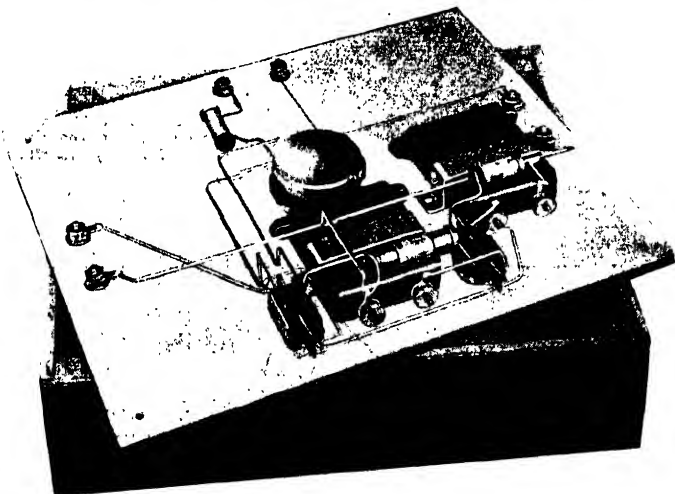

An under view of the bridge. All components are mounted on the panel which forms the lid of the box

ponents must be accurately known, and if the bridge is to have any pretensions to accuracy and reliability good quality components having values within ± 1 per cent. of their ratings must be used.

The total value of the balancing potentiometer R_5 has no effect on the accuracy, and it is only necessary that the ratio of the two halves be the same in different potentiometers for all positions of the slider in order to permit a printed scale to be used. This requirement is met quite well when a uniformly wire-wound potentiometer is used,

WIRELESS SERVICING MANUAL

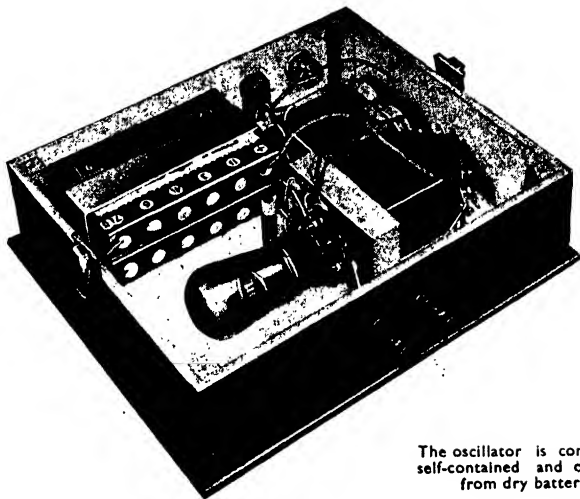

The oscillator is completely self-contained and operated from dry batteries

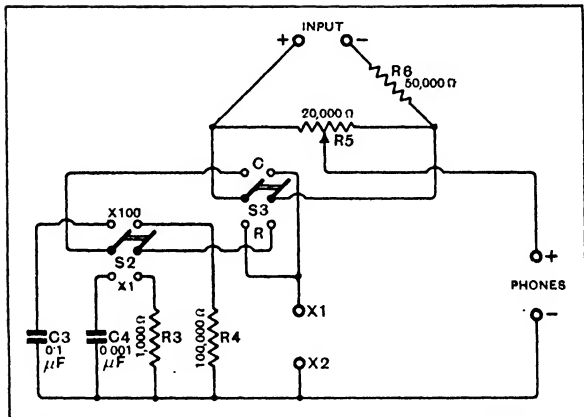

Fig. 2 : The complete circuit diagram of the bridge, showing the switching arrangements

CAPACITY AND RESISTANCE BRIDGE

and although the accuracy may suffer slightly through the absence of individual calibration, this is the inevitable price which must be paid for avoiding the trouble of calibration.

Constructionally, the components are all secured to a wooden panel which forms the lid of a shallow box, and to which the scale printed in Fig. 4* may be pasted. The only non-standard part employed is the pointer, which is best cut from a strip of brass and screwed to the control knob by two 8BA screws. Holes must be drilled and tapped in the knob to receive these screws, and some care is needed in carrying out this operation, for the bakelite is apt to crumble somewhat.

A source of alternating current is necessary to energise the bridge. A.C. mains are not suitable, and the simplest arrangement is to use a buzzer, connecting the input terminals of the bridge across the coil of the buzzer. The writer must confess, however, to a dislike of buzzers on account of their unreliability and their mechanical noise. Cheap buzzers are very troublesome, being difficult to start buzzing properly and liable at any moment to cease work. Good reliable buzzers usually cost as much as a valve oscillator and suffer from the disadvantage that the direct noise often renders it difficult to distinguish the exact balance point in the phones.

In the writer's experience a valve oscillator is the best, since it is both reliable and silent, and it is not unduly expensive. The circuit of a suitable oscillator is given in Fig. 3, and it is recommended that it be built as a separate unit so that it is available for other purposes, such as energising a bridge of different type, testing A.F. amplifiers, and modulating an R.F. oscillator. A single valve is used as a Hartley oscillator with a 3H choke tuned by a 0.01 μ F condenser C1. Two dry cells are provided for L.T. and operate the valve through a 10-ohm resistance R2. With new batteries the voltage on the valve does not exceed 2.2 volts, which is no more than would be obtained with a freshly charged accumulator applied directly to the filament. Experiment has shown that the valve will continue to oscillate until the filament potential falls to about 1.5 volts, so that there is a wide latitude for falling battery voltage, and an adjustable resistance is unnecessary. The H.T. supply is provided by two 9-volt batteries, and as negative H.T. is connected to positive L.T., the filament battery is effective in increasing the H.T. supply. With new batteries rather more than 21 volts H.T. is available, and oscillation continues until the H.T. falls below some 15 volts, so that here, also, ample allowance has been made for falling battery voltage. An on-off switch has been provided, and a pilot lamp to give warning that the oscillator is on and so remind one to switch it off when it is no longer being used.

In order to reduce the load of the bridge on the oscillator and prevent wide variations in frequency and amplitude with different capacities, a 50,000-ohm resistance, R6, is joined in one of the bridge input leads. If a buzzer be used for energising the bridge it may

* For Fig. 4 see folded inset facing page 328

WIRELESS SERVICING MANUAL

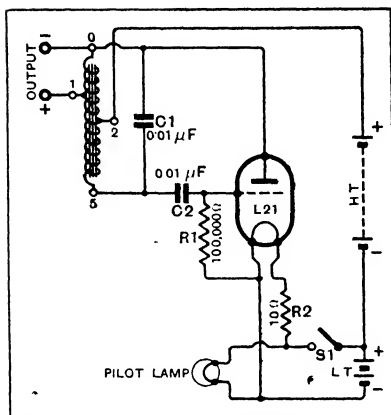
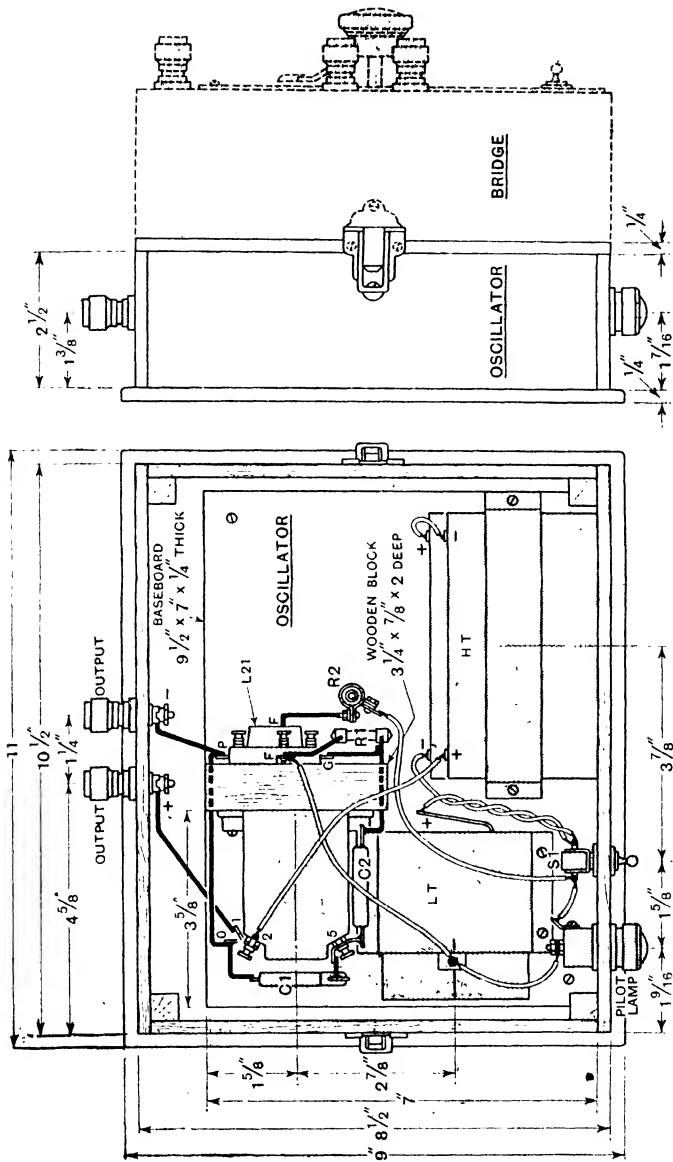

Fig. 3 : The oscillator is of simple type and economical in operation

prove necessary to short-circuit this resistance. A pair of high-resistance phones must be used, and with nothing connected to the "X" terminals the oscillator note should be quite loud. The condenser or resistance to be measured should be connected to the "X" terminals and the switch set appropriately to "C" or "R." In most cases the value will be approximately known and the range switch can then be set appropriately. The balance point will be found to be quite definite, although complete extinction of the note may not

always be obtained. The minimum, however, is so definite that it cannot be mistaken; it is not obscured by oscillator harmonics.

The reason why a null-point is not always obtained is that no provision is made for balancing out the effect of any resistance in the condenser being tested nor for balancing out the effect of capacity in the resistance being measured. Normally, these effects are small with good components, and the extra complication to the bridge and its operation is not worth while. If it be found, therefore, that with a particular component a bad balance is secured, it is possible that, if a condenser, it has a bad power factor, or if a resistance, it has a high self-capacity.



The oscillator section of the capacity and resistance bridge described in Appendix III

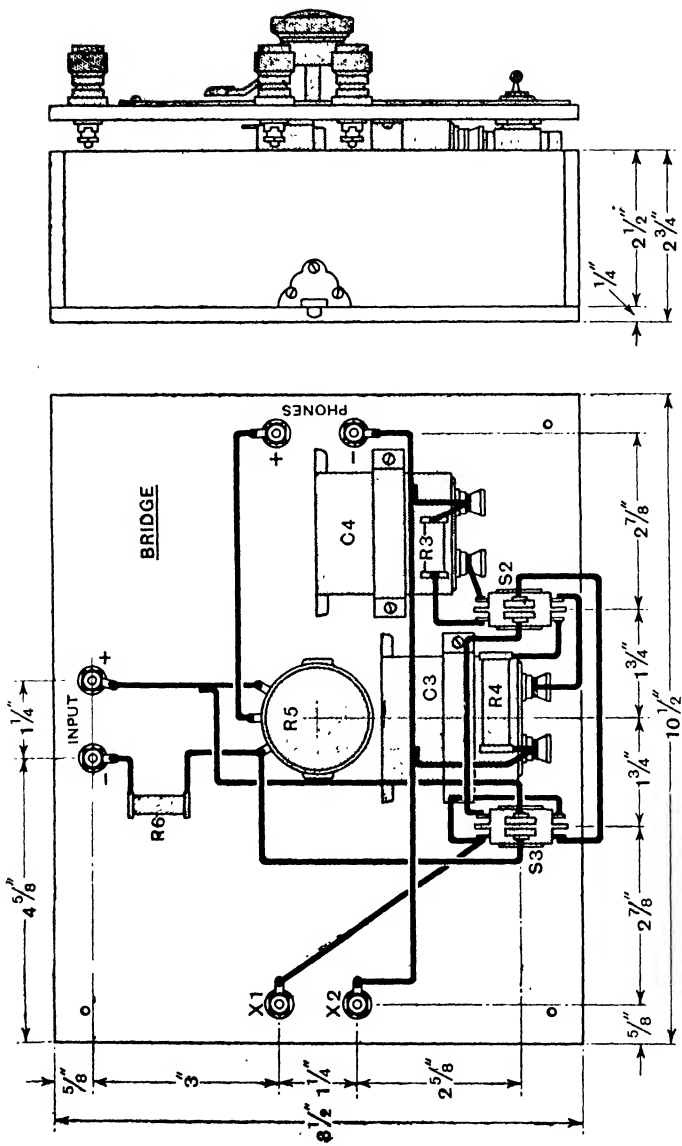

Layout and wiring of the capacity and resistance bridge described in Appendix III

CAPACITY AND RESISTANCE BRIDGE

It must be remembered that the reading of capacity obtained includes the self-capacity of the bridge and connecting leads. This can readily be determined by balancing the bridge for capacity with nothing connected to the "X" terminals, and was about $30 \mu\mu\text{F}$ for the original instrument. In order to obtain the true capacity of a condenser, therefore, this figure must be deducted from the reading obtained. This correction is unimportant for capacities higher than $1,000 \mu\mu\text{F}$.

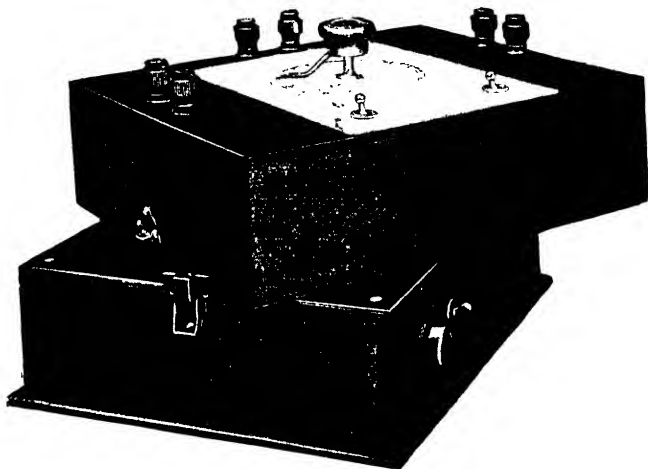

The bridge is arranged to fit over the oscillator and is held in place by spring clips. A view of the complete unit is on page 7

Even when no attempt at individual calibration is made, and the printed scale is used, care must be taken to set the pointer correctly. This may, of course, be done by the end marks which indicate the limits of travel of the pointer, but for the greatest accuracy it would be wise to obtain a 1,000 ohms resistance within ± 1 per cent. (such resistances are not expensive) and to balance the bridge with this resistance connected to the "X" terminals. Leaving the bridge balanced, set the pointer to read exactly 1,000.

It may be remarked that no earth connection must be used on any point of the bridge or oscillator. The condenser or resistance under test must be disconnected from other gear, otherwise appreciable errors may be introduced.

WIRELESS SERVICING MANUAL

WIRELESS WORLD CAPACITY AND RESISTANCE BRIDGE

LIST OF PARTS

BRIDGE

- 1 Wire wound potentiometer, 20,000 ohms non-taper, R5
Reliance "TW"
- 1 Resistance, 50,000 ohms, 1 watt, R6
Bulgin
- 1 Resistance, 1,000 ohms, accuracy ± 1 per cent., 1 watt R3
Bulgin
- 1 Resistance, 100,000 ohms, accuracy ± 1 per cent., 1 watt R4
Bulgin
- 1 Fixed condenser, mica 0.1 μ F., accuracy ± 1 per cent., C3
Muirhead M71
- 1 Fixed condenser, mica 0.001 μ F., accuracy ± 1 per cent., C4
Muirhead M71
- 2 Switches, DPDT, S2, S3
Bulgin S98
- 1 Knob
Bulgin K12
- 6 Ebonite shrouded terminals, "phones" (2), "input" (2),
"X1," "X2"
Belling-Lee "B"
- Wood, wire, screws, etc.

OSCILLATOR

- 1 Valve holder, 4-pin
WB Baseboard type
- 1 Tapped choke, 3 henries
Varley DP18
- 1 Resistance, 100 000 ohms, $\frac{1}{2}$ watt, R1
Bulgin HW25
- 1 Resistance, 10 ohms, R2
Bulgin AR10
- 2 Fixed condensers, 0.01 μ F., C1, C2
Dubilier 670
- 1 Switch on/off, S1
Bulgin S80T
- 1 Flush signal lamp with 12mm. 60 mA. bulb
Bulgin D9
- 1 3-volt battery
Ever Ready, Large
Twin 2-cell 800
- 2 Grid bias batteries, 9 volts
Ealex
- 4 Wander plugs
Belling-Lee "B"
- 2 Ebonite shrouded terminals, "output"
Osram or Marconi
- 1 Valve, L21
Wood, wire, screws, etc.

APPENDIX IV

Valve Testing Bridge

A simple method of measuring valve constants has been a long-felt want. The construction of inexpensive gear for the measurement of mutual conductance is here described in detail, and it enables all types of valves other than diodes to be tested

THE measurement of valve constants normally demands quite elaborate apparatus, and this is especially the case when a high degree of accuracy is required. It is because of this that the usual valve-tester operates merely as an emission tester combined with a very rough check on mutual conductance. The required voltages are applied to the valve and the anode current noted; the grid bias is then increased by a known amount and the new value of anode current recorded. The change in anode current divided by the change in grid voltage gives a figure representing mutual conductance, while the values of anode current themselves give an indication of the state of emission.

The results are only of value if it is known what the figures should be for the particular valve under test. The change of grid bias, for instance, used in estimating mutual conductance must necessarily be too large for the valve constants to be the same at both voltages, for it must never be forgotten that the so-called valve constants are not constant. They depend upon the construction of the valve, it is true, but also to a very large degree upon the voltages applied to the valve. With a triode the amplification factor (μ) usually varies very little with the operating conditions, but the anode AC resistance (R_a) varies enormously. The ratio μ/R_a , which is called the mutual conductance (g) naturally varies also.

The most accurate method of measuring the constants is by means of a suitable A.C. bridge, and all three constants can be measured directly. The apparatus becomes quite expensive, however, when it is required to determine all three with accuracy over the wide ranges of values encountered in practice. The A.C. resistance of modern valves ranges from 500 ohms for an output triode

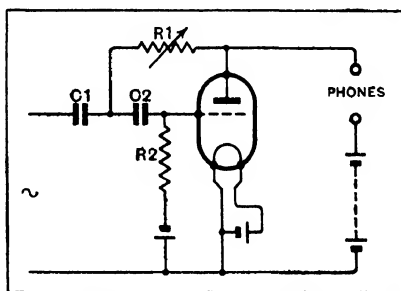
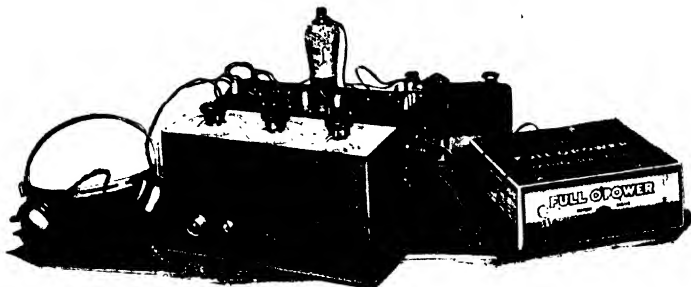

Fig. 1: The basic circuit of the mutual conductance bridge

WIRELESS SERVICING MANUAL



The bridge wired up, with a valve inserted for test

to 10 megohms or more for an R.F. pentode at a high grid bias, while the amplification factor may be as low as 2.0 or as high as 10,000. Mutual conductance covers an equally wide range, from 0.001 mA/V to 10.0 mA/V.

Were we concerned only with triodes of ordinary design, it would be as easy to measure one constant as another, but when extreme values are encountered this is not always the case. In general, it is easier to measure mutual conductance than either of the other constants, and the A.C. resistance is the most troublesome. The most valuable single constant is mutual conductance, for it reveals more about the condition of a valve than either amplification factor or A.C. resistance alone.

There are several methods of measuring mutual conductance, and the simplest, from the point of view of calibrating the apparatus, is that shown in Fig. 1. The condenser C_1 serves merely to prevent the H.T. supply being short-circuited through the source of alternating current, and ideally the combination of C_2 and R_2 , which are included merely to isolate the grid of the valve from the H.T. supply, would cause no attenuation and no phase shift. Given these conditions, the input voltage is applied to the grid of the valve directly and to the anode through R_1 . Owing to the reversal of phase which takes place in the valve, two voltages of opposing phase appear in the anode circuit, and when they are exactly equal in magnitude no sound can be heard in the telephones. The magnitude of the voltage which comes via the valve depends upon the mutual conductance and the magnitude of the opposing voltage upon the value of R_1 .

In practice the value of R_1 is varied until silence is obtained in the telephones, and it can be shown that the mutual conductance in milliamperes per volt is equal to $1,000/R_1$ where R_1 is in ohms. In order to measure mutual conductance over the range of 10.0 mA/V to 0.01 mA/V, therefore, R_1 must be variable from 100 ohms to 100,000 ohms.

The condenser C_2 and resistance R_2 will introduce an error if they cause the voltage actually applied to the grid of the valve to be

VALVE TESTING BRIDGE

appreciably less than that fed to R_1 . The error can be made negligibly small, however, by assigning large enough values to these components. Of greater importance is the phase shift which they introduce. When the grid and anode voltages are not in exactly the same phase, no silent point can be found when adjusting R_1 for balance, but only a minimum. This makes the adjustment difficult and liable to error. Minimum phase change and the best balance are secured by using large values for C_2 and R_2 , so that the requirement is the same as for avoiding attenuation; it is, however, much more severe.

At first sight it would seem that one could use for these components the values customarily employed in a resistance-coupled amplifier. It is, however, often required to take measurements of valves operating with zero grid bias, for the makers' figures for mutual conductance are usually quoted for this condition. The valve may then pass grid current, and if there is a resistance in the grid circuit the bias will no longer be zero but slightly negative. In order to make the discrepancy negligible it is necessary to make R_2 quite low, and a value of 2,000 ohms has been found satisfactory. With this low value of resistance it is necessary to give C_2 a capacity of $8 \mu\text{F}$ to maintain the phase change at a satisfactorily low degree.

Using these values a very good balance is secured over the wide range of 0.1 - 10.0 mA/V ; although complete silence is not secured, the balance point is very sharp and definite. For lower values of mutual conductance the balance deteriorates somewhat, but is reasonably accurate down to 0.01 mA/V .

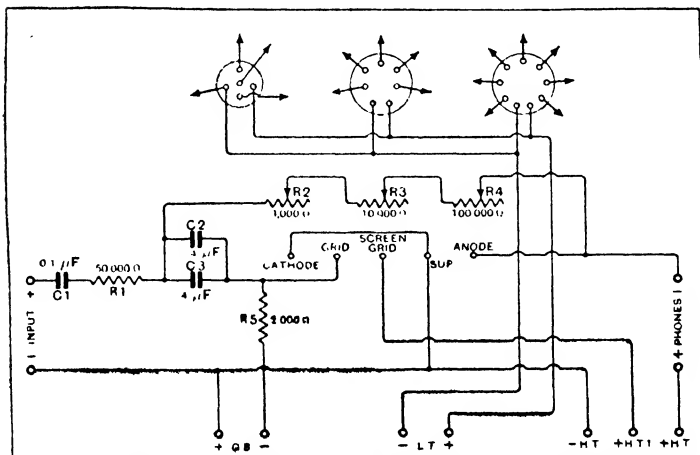
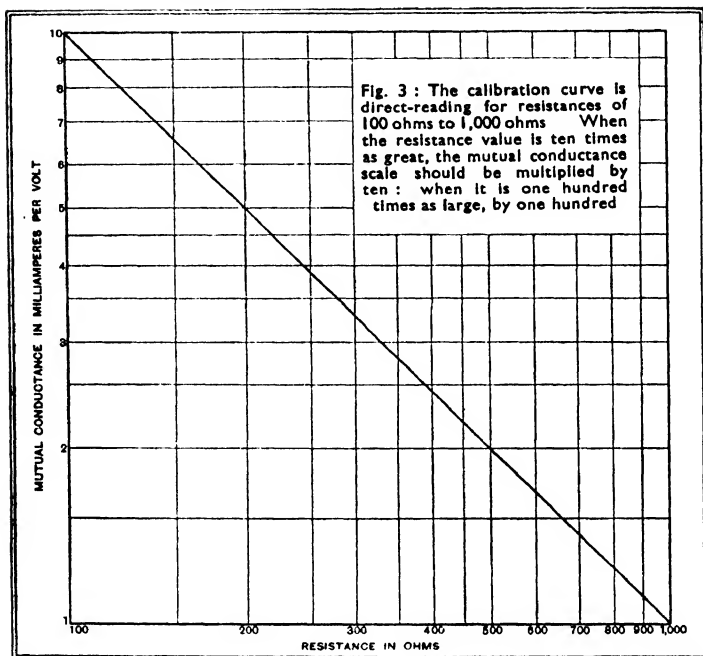

Fig. 2 : Complete circuit of the apparatus. Flex leads, fitted to the valve holders and terminating in wander plugs, enable any valve to be accommodated

WIRELESS SERVICING MANUAL



Since the mutual conductance is proportional to the reciprocal of resistance, the scale cannot satisfactorily be made direct reading. In order to obtain a reasonably open scale it would be necessary to have a tapered resistance with an extraordinarily high degree of taper—probably too great to manufacture. The scale is consequently calibrated in resistance values, and to obtain the mutual conductance it is necessary either to work out the reciprocal or refer to the conversion curve given in Fig. 3

The photographs and drawings clearly show the construction of the gear which is designed to work with the oscillator, which is described in Appendix III, for a Capacity and Resistance Bridge. The complete circuit diagram appears in Fig. 2, and it will be seen that three variable resistances are employed for balancing. This is done in order that a high degree of accuracy may be obtained over a wide range. The resistance R_2 has a maximum value of 1,000 ohms, R_3 10,000 ohms, and R_4 100,000 ohms. For mutual conductances higher than 1 mA/V only the 1,000 ohms resistance R_2 should be used, R_3 and R_4 being set at zero. The 10,000 ohms resistance R_3 should be employed for mutual conductances between 1 mA/V and

VALVE TESTING BRIDGE

0.1 mA/V. while the third resistance R_4 is for values down to 0.01 mA/V. Whichever resistance is being used, the other two must be set at zero. It is, of course, possible to employ the three resistances in the manner of a decade box, setting the high values only at tenths of the maximum values. This is somewhat more troublesome, but is slightly more accurate at high values of resistance.

Three valve holders are embodied but any number of additional ones can be fitted. The filament sockets are all wired in parallel and connected to the L.T. terminals. For battery valves a 2-volt accumulator should be joined to these, but for A.C. valves either a 4-volt accumulator or the 4-volt winding of a mains transformer. The remaining sockets of the valve holders cannot be permanently wired, for the connections required depend upon the particular valve to be tested. A flex lead terminating in a wander plug is therefore attached to each socket, and a row of five sockets is provided for them. When not in use the plugs are kept tidy by being placed in holes drilled in the wooden panel. Only a few of the plugs are in use at any one time.

For directly heated valves the filament plug is inserted in the cathode socket, but for indirectly heated types the cathode plug is

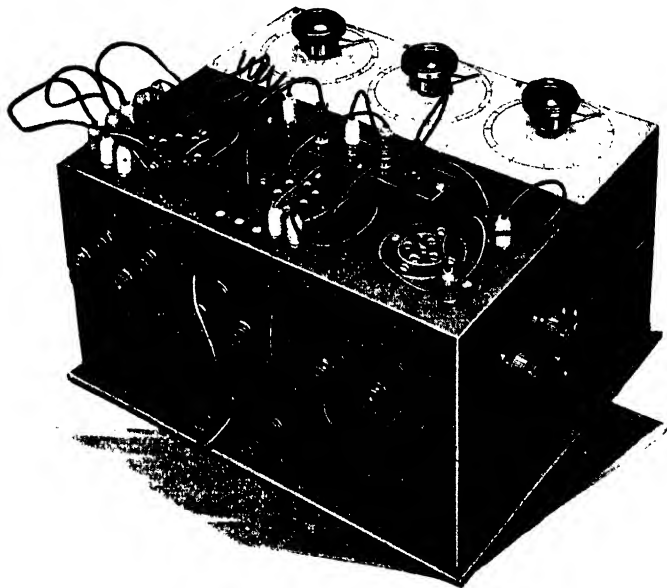

The bridge on top of the oscillator used for energising It. Full details of this oscillator are given in Appendix III

WIRELESS SERVICING MANUAL

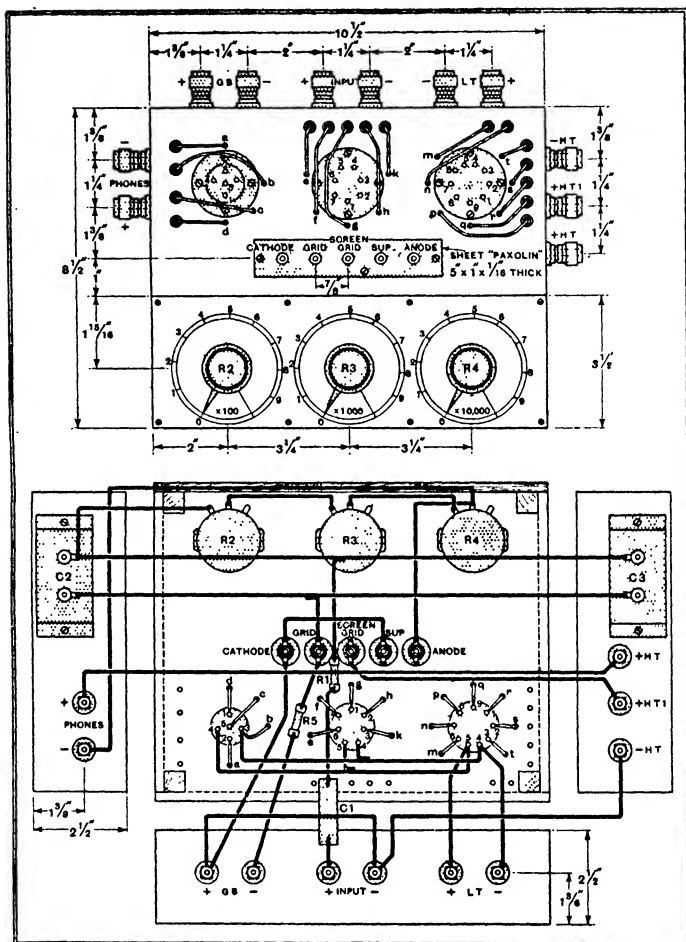

Full constructional and wiring details of the bridge. A list of parts is given on page 307

VALVE TESTING BRIDGE

WIRELESS WORLD VALVE TESTING BRIDGE

LIST OF PARTS

- 1 Valve holder, 5-pin (without terminals) Clix Chassis Mounting Type V₁
- 1 Valve holder, 7-pin (without terminals) Clix Chassis Mounting Type V₂
- 1 Valve holder, 9-pin (without terminals) Clix Chassis Mounting Type V₂
- 2 Fixed condensers, 4 μ F. 500 volts DC test, C₂, C₃ Dubilier B₅
- 1 Fixed condenser, 0.1 μ F. tubular, C₁ Dubilier 4513
- 1 Resistance, 50,000 ohms $\frac{1}{2}$ watt, R₁ Bulgin HW23
- 1 Resistance, 2,000 ohms $\frac{1}{2}$ watt, R₅ Bulgin HW5
- 1 Potentiometer, wire wound, non-taper, 1,000 ohms, R₂ Reliance S/W₁₀
- 1 Potentiometer wire wound, non-taper, 10,000 ohms, R₃ S/W₁₁
- 1 Potentiometer, wire wound, non-taper, 100,000 ohms, R₄ Reliance S/W₁₂
- 3 Knobs Bulgin K₁₂
- 11 Ebonite shrouded terminals, input +, input -, phones +, phones -, grid +, grid -, LT +, LT -, HT +, HT + 1, HT - Belling-Lee "B"
- 17 Wander plugs Ealex
- 5 Sockets Ealex
- Wood, systoflex, wire, screws, etc.

used and the filament plug left free. Whichever valve sockets they may be, the grid, screen grid, suppressor grid, and anode must always be joined to the appropriate sockets in the centre by the flex leads. If the valve has a top cap or side terminal this must be joined to the appropriate socket by a separate lead terminating in a plug. Any other pins of normal valves need not be connected, for metallising and diode anodes can be left free.

Terminals are provided for the grid bias and H.T. batteries. For normal tests when the results will be compared with the valve makers' figures the grid bias terminals will be short-circuited, and for triodes 100 volts H.T. should be used. Actually the anode potential should be 100 volts, and it will be less than the battery voltage by the drop in the telephones. Strictly speaking, therefore, the battery voltage should be adjusted so that the voltage measured between the cathode and anode sockets on the panel is 100 volts with the valve in place and operative. When power valves are being measured the current may be quite large and the voltage drop across a pair of phones will be high. In order to avoid this and to protect the phones it is best

WIRELESS SERVICING MANUAL

to use an output transformer with a low primary resistance. Alternatively, the phones can be shunted by a choke of low D.C. resistance ; the inductance need not be high, for 2H or 3H is sufficient. Measurements of anode current can, of course, be made by connecting a suitable milliammeter in the positive lead to the high-tension battery.

Little more need be said about the uses of the instrument or the method of connecting it up for different valves, for these are obvious. The question of calibration must receive attention, however, and this is easily done with the aid of the resistance bridge already referred to. A sheet of white paper, or, better, ivorine, should be fastened to the panel to receive the scale, and the two extreme ends of the three resistances used for balancing joined to the resistance bridge. Set R₃ and R₄ to zero and the resistance bridge to 100 ohms. Adjust R₂ for silence, and mark off the scale for 100 ohms. Then set the bridge to 200 ohms, and repeat. As many intervening values as are required can be marked off, and when this resistance has been done, R₃ can be tackled. Here both R₂ and R₄ must be at zero and this is calibrated in 1,000-ohm steps with suitable intermediate steps. Lastly, R₄ is calibrated in 10,000-ohm steps with R₂ and R₃ at zero. The process is quite easy, which is fortunate, for it is not possible to rely on variable resistances being sufficiently consistent for a printed scale to be used.

- Distortion, Amplitude, 69
 —, Detector, 75
 —, Frequency, 65
 —, R.F. and I.F., 79
- Earth, 210
 Electric deflection, 261
 Electromagnetic deflection, 265
 Extension loud speaker, 205
- Feed-back, Acoustic, 131, 196
 — from A.F. circuits 61
 — I.F. harmonic, 138, 143
 — in television apparatus, 257
 — modulation by A.F., 53
- Feeders, Aerial, 214
 Filters, Crystal, 189
 Fly-back, 261, 266
 Focus, Television, 264
 Formulæ, Useful, 280
 Frequency-changers, 148
 —, Heptode, 152
 —, Octode, 152
 —, One-valve, 149
 —, Triode-heptode, 152
 —, Triode-hexode, 152
 —, Two-valve, 148
- Frequency, Control circuit, 218
 — Distortion, 65
 — modulated oscillator, 274
 — stability, 154, 159
- Ganging, Straight Sets, 91
 — Defects, 97
 — with capacity and inductance trimmers, 101
 — on long waves, 94
 — on medium waves, 93
- Ganging, Superheterodynes, 115
 — — with capacity and inductance trimmers, 124
 — — adding system, 117
 — — shaped-plate condenser, 123
 — — I.F. amplifier, 104
- Gramophone pick-up, 207, 247
 Grid detectors, 75
- Harmonics, I.F., 137, 143
 — Oscillator, 138
- Heater, Circuits, 64
 — -Cathode insulation, 21, 25
- Heptode, 152
 Hexode, 152
 Howl, Threshold, 184
 Hum in A.C./D.C. sets, 42
 — in A.F. stage, 37
 —, Electric pick-up, 38, 39
 —, Filament supply, 34
 —, Gramophone, 40, 41
 —, Grid bias, 34
 —, Loud speaker, 31
 —, Modulation, 43
 —, Output stage, 33
 —, Pick-up in A.F. transformer, 36
 —, Quick tests for, 40
 —, in R.F. stage, 39
 —, Screen supply, 35
 —, Television, 266
 —, Valve 37
- I.F. amplifier adjustments, 104
 — A.V.C. system, 112
 — Estimating value of, 146
 — harmonic feed-back, 138
 — harmonic interference, 137, 143
 — over-coupled circuits, 108
 — pick-up, 142
 — variable selectivity, 117
- Image interference, 136
 Impedance matching, 202, 215
 Inductance, Bridge, 5
 — trimmers, 101, 124
- Instability, Capacity couplings, 56, 58
 — Heater circuits, 64
 — Impedance coupling, 56
 Instability, Magnetic coupling, 57
 — R.F. in A.F. circuits, 61
 — Sources of, 55
 — Stabilising, 59
 — Variation with tuning, 55
- Insulation, Valve heater-cathode, 21, 25
- Interference, Beat, 137
 — from sound transmitter, 258
 — I.F. harmonic, 137
 — I.F. pick-up, 142

INDEX

- Interference, Image, 136
 — Local, 84
 — Man-made static, 84
 — Noise, 81
 — Oscillator harmonic, 138
 — Parasitic oscillation, 82
 — Screened lead-in, 87
 — Second channel, 136
 — Silencing electric motors, 89
 — Superheterodyne whistles, 136
 — Suppressors, 89
 — Thermal agitation, 81
 — Thermostats, 89
 — Whistles, 129, 136
- Leaky coupling condenser, 21
 Local-Distance switch, 79
 Local interference, 84
 Loose connection, 81
 Loud speakers, 199
 — Baffles, 200
 — Box resonance, 201
 — Centring cones, 199
 Loud speakers, Colour code, 288
 — Extension, 205
 — Mains hum in, 31
 — Matching to valve, 202
- Magnetic coupling, Instability due to, 57
 Mains equipment, 17
 — hum, see Hum
 — Transformer, Colour code, 290
 Man-made static, 84
 Matching ganged condensers, 100
 — Impedance, 202, 215
 — Speaker and valve, 202
 Measurements, Capacity, 292
 — Continuity, 4
 — Current, 13
 — Inductance, 5
 — Mutual conductance, 27, 301
 — Resistance, 292
 — Voltage, 9
 Metal rectifiers, A.V.C. with, 177
 Meter-readings, Interpretation of, 16
 — Tests, A.C. voltages, 17
 — Low mains voltage, 16
- Meter-readings, Low volts, high current, 18
 — Low volts, low current, 18
 Meters, Constructing, 1
 — Ohmmeter, 4
 — Milliammeter, 3
 — Voltmeter, 2
 Microphones, 207
 Microphony, 25, 131, 196
 Milliammeter, 3
 — as tuning indicator, 95
 — Constructing a multi-range, 3
 — Using the, 13
 Mixers, 148
 Modulation hum, 43
 Motor-boating, A.F., 47
 — A.V.C., 53
 — modulation, 53
 — R.F., 53
 Motors, Silencing, 89
 Muting, 177
 Mutual conductance, 27
- Negative feed-back, 250
 Neutralising, 245
 Noise, Hiss, 81
 — Local interference, 84
 — Loose connections, 81
 — Man-made static, 84
 — Parasitic oscillation, 82
 — Thermal agitation, 81
 — Valve, 81
- Octode, 152
 Ohmmeter, 4
 Oscillation, see Instability
 — Parasitic, 82
 Oscillators, 154
 — Amplitude of, 156
 — beat frequency, 187
 — coil connections, 156
 — frequency stability, 159
 — test, 5
 Output meter, 7
 — transformer, 203
 Ozone, 268
- Paraphase amplifiers, 238, 261
 Parasitic oscillation
 — in A.F. stages, 73

INDEX

- Parasitic oscillation in oscillators, 83
 -- in push-pull, 242
 -- in R.F. stages, 82
 Pentode, R.C. coupled, 71
 "Plastic," 260
 Pulling, 195
 Push-pull amplifiers, 228
 -- Bias in, 230
 -- Decoupling in, 231, 239
 -- Parasitic oscillation, 242
 -- Phase-splitters, 234
 -- Resistance-coupled, 232
 -- Transformer-coupled, 229
- Q.A.V.C., 177
 Q.P.P., 71
- Reactance valve, 218
 Reaction, 244
 -- in S.W. sets, 183
 Resistance bridge, 5
 -- colour code, 288
 -- testing, 22
 Resonance, Box, 201
 Resonant aerials, 213, 285
- Screen currents, 22
 Screened lead-in, 87
 Second-channel interference, 136
 Selectivity, Variable, 109
 Short-wave Aerials, 213, 285
 -- Conditions, 180
 -- Converters, 193
 -- Cross-modulation, 186
 -- Dead spots, 185
 -- Receivers, 180
 -- Sets, Choosing a detector, 182
 -- Threshold howl, 184
 Signal generators, 7
 Signal-noise ratio, 209
 Silencing electric motors, 89
 Sound transmitter, Interference from, 258
 Stabilising receivers, 58
 Standard symbols, 279
 Superheterodyne, ganging, 115
 -- Whistles, 136
 Switching, Waveband, 23
 Synchronisation, 268
- Television, 257
 -- electric deflection, 261
 -- electromagnetic deflection, 265
 -- focus, 264
 -- Intermittent condenser breakdown, 263
 -- Tube-base sparking, 268
 -- Voltage supplies, 267
 Test oscillators, 5
 Thermal agitation, 81
 Thermostats, 89
 Threshold howl, 184
 Tone control, 68, 248
 Tools, 1
 Transformers,
 -- colour code, 290
 -- distortion, 203
 -- ratio, 202
 Transposed feeder, 88
 Trimming I.F. amplifiers, 104
 Triode-heptode, 152
 Triode-hexode, 152
 Tuning control, A.F.C., 217
 Tweeters, 203
- Ultra short waves, 197
 Useful formulae, 280
- Valve adaptors, 14
 -- Bridge, 301
 -- Data, 309
 -- heater-cathode insulation, 21, 25
 -- Hum, 37
 -- Mutual conductance, 301
 -- Noise, 25, 81
 -- Testing, 301
 -- Variable-mu, 11
 Variable selectivity, 109
 Ventilation, 161
 Vibrating condenser vanes, 131, 196
 Visual circuit alignment, 274
 Voltage measurements, 9
 Voltmeter, 1
 -- Constructing a multi-range, 2
- Waveband switching, 23
 Wavemeter, Absorption, 139
 Wavetraps, Adjusting, 126

I N D E X

- Whistles, A.F., 129
 - Filters, 132
 - Fixed, 129
 - Inter-station, 132
 - Microphonic, 131
 - Superheterodyne, 136
 - Variable intensity, 132
- Variable pitch, 136
- Wire tables, 286
- Wireless World capacity and resistance bridge, 292
 - — valve testing bridge, 301
- Wobblers, 274

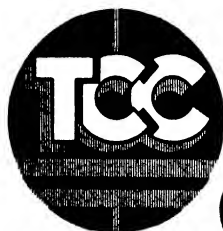
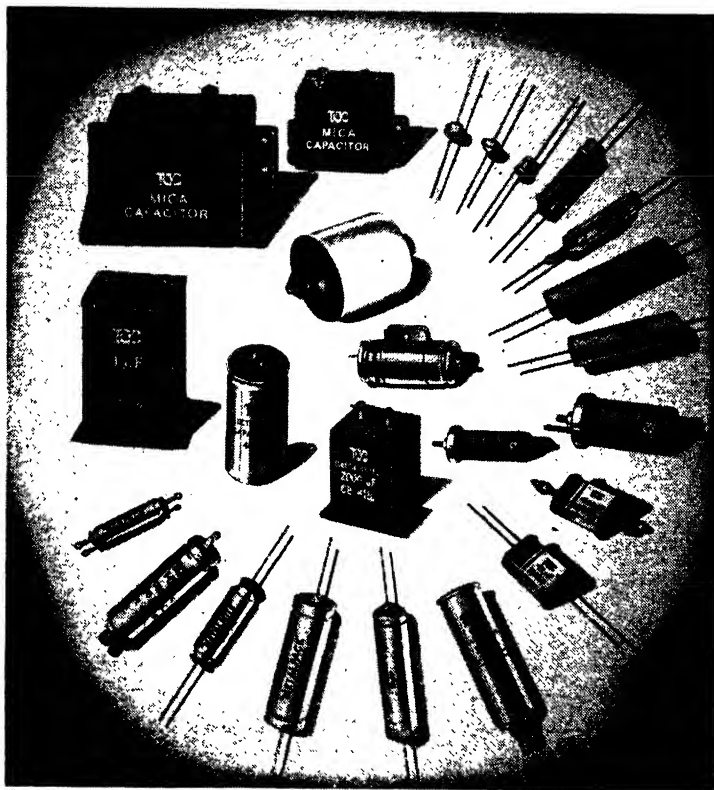

ELECTROLYTIC (WET AND DRY), PAPER, MICA AND
 CERAMIC CAPACITORS FOR RADIO RECEIVERS AND
 TRANSMITTERS • TELEGRAPHY AND TELEPHONY •
 ELECTRONIC EQUIPMENT AND INTERFERENCE SUPPRESSION

CAPACITORS

THE TELEGRAPH CONDENSER CO. LTD. (RADIO DIVISION), NORTH ACTON, LONDON, W.3

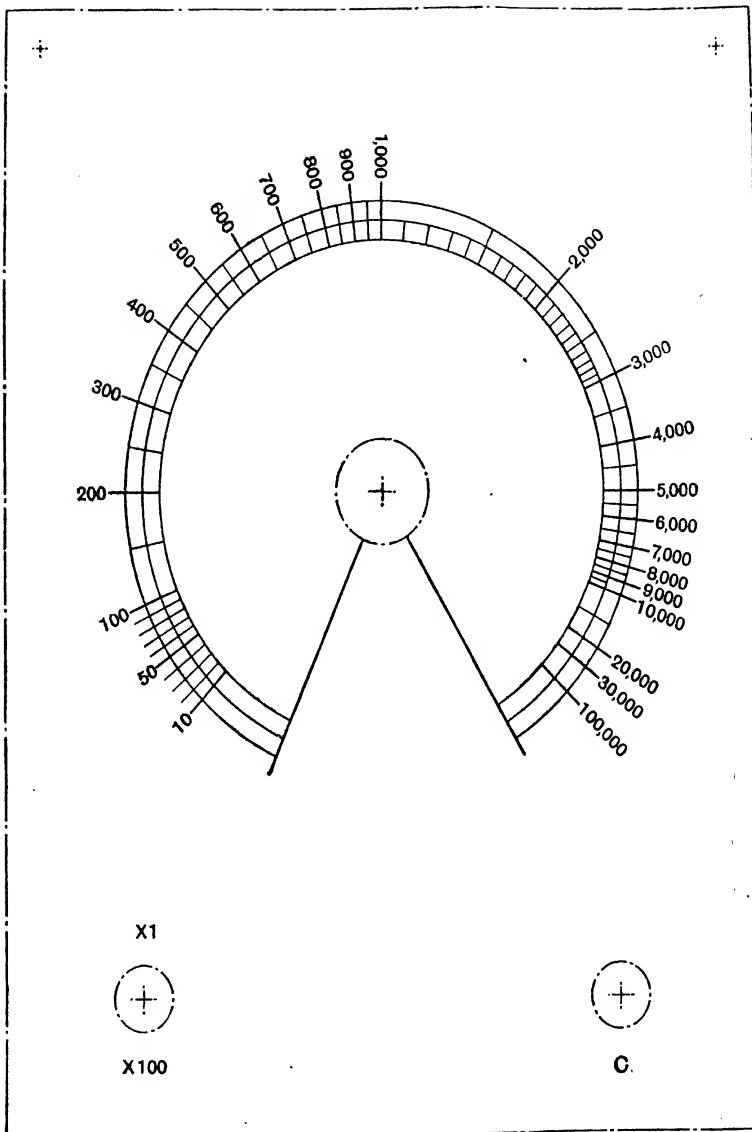

See page 295, Appendix III

Fig. 4



Built-in multiple plugs and sockets with mechanical couplers instantaneously complete all electrical circuits and secure a number of Units into a rigid assembly without the use of tools.



AIDS TO BETTER SERVICING

Designed for the Radio Engineer, L.A.L. Units cover every need from D.C. to R.F. The range includes : Type 15, C.R.T. unit (6" tube and self-contained shift supplies); Type 84, Time Base (5-200,000 cps. with sweep expansion; automatic synchronizing; push-pull deflection; single or triggered sweep; Type 84Y, Amplifier (gain 25, cathode follower input, or 600; response level ± 1 db 10-100,000 cps., useful at 0.5 Mc.; push-pull deflection).



Lydiate Ash

LABORATORIES

LYDIATE ASH · NEAR BROMSGROVE · WORCS.

Also :

D.C. Amplifiers, medium and high gain. Extra low frequency time base. Circular or spiral heptode time base. Voltage calibrator.

BELLING-LEE CONNECTIONS

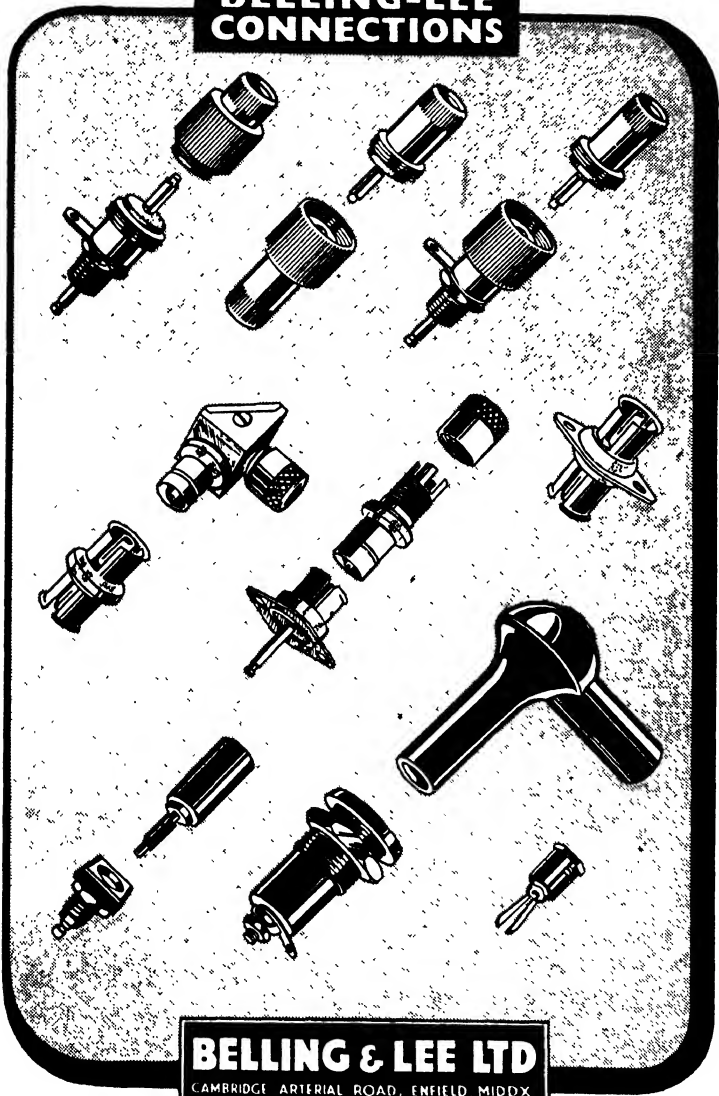

BELLING & LEE LTD
CAMBRIDGE ARTERIAL ROAD, ENFIELD, MIDDXX

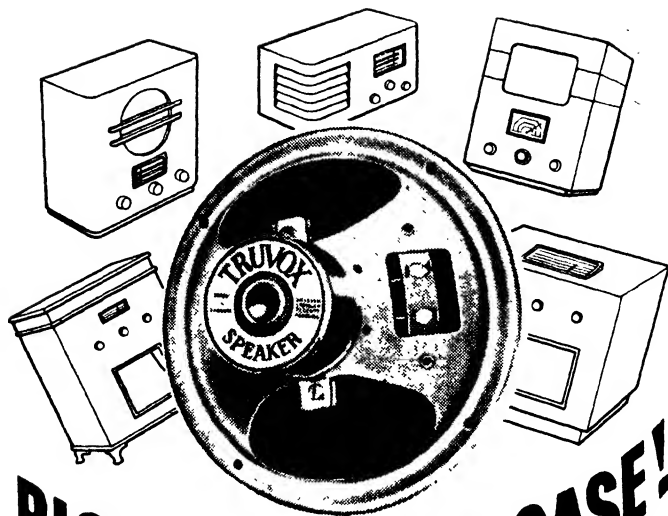

5-inch Model BX50, 8, 500 lines, £1.1.0; Model BX52, 10,000 lines, £1.4.6.

6½-inch Model BX60, 8,500 lines, £1.2.6; Model BX62, 10,000 lines, £1.6.0.

8-inch Model BX80, 8,000 lines, £1.4.0; Model BX82, 10,500 lines, £1.10.0.

10-inch Model BX100, 8,000 lines, £1.10.0; Model BX102, 10,500 lines, £1.17.6.

Whenever a new speaker is required, fit a Truvox and make another customer into a firm friend. Full technical details on leaflet SH/142; a postcard will bring it to you. Supplies from your regular wholesaler—there's a range of Extension Speakers too!

TRUVOX

TRUVOX ENGINEERING CO. LTD.
EXHIBITION GROUNDS, WEMBLEY
(Wembley 1814)

'AVO'

Registered Trade Mark



Precision ELECTRICAL TESTING INSTRUMENTS

The "AVO" MULTI-RANGE ELECTRONIC TESTMETER

THIS instrument, which operates with the simplicity of an ordinary moving-coil meter, is an up-to-date example of current instrument practice. It is a highly stable thermionic D.C. Millivoltmeter with circuit switching, giving 49 ranges in the following:

D.C. Volts: 2.5 mV. to 10,000v. — Input Resistance 111.1 megohms.

D.C. Current: 0.25 μ A to 1 Amp. — 150 mV. drop on all ranges.

A.C. Volts: 0.1v. to 2,500v. R.M.S. up to 1 Mc/s.

With external diode probe 0.1v. to 250v. up to 200 Mc/s.

A.C. Output Power: 5 mW. to 5 watts in 6 different load resistances from 5 to 5,000 ohms.

Decibels: -10 db. to +20 db.

Capacitance: 0.001 μ F. to 50 μ F.

Resistance: 0.2 ohms to 10 megohms.

Insulation: 0.1 megohm to 1,000 megohms.

The thermionic circuit gives delicate galvanometer sensitivity to a robust moving-coil movement. It is almost impossible to damage by overload and is as easy to handle as the standard "Avo" multi range meter.

The instrument is quickly set up for any of the various tests to be undertaken, a single circuit selector switch automatically removing from the circuit any voltages or controls which are not required for the test in question.

Fully descriptive leaflet available on application

Now Available: The H.R. AVOMETER, with all the well-known features of the Universal AvoMeter, and with a sensitivity of 20,000 ohms per volt

Sole Proprietors and Manufacturers

THE AUTOMATIC COIL WINDER & ELECTRICAL EQUIPMENT CO. LTD

Winder House, Douglas Street, London, S.W.1

Telephone: VICTORIA 3404-9

Which of these is your pet subject ?

General Radio Engineering
Television

High Frequency Engineering
Sound Film Projection

Engineering

General Electrical Engineering
Telegraphy

Radio Servicing,
Maintenance and Repairs

Short Wave Wireless
Ultra Short Wave

Communications

Electrical Installations
Telephony

We have courses in practically every Technical subject including Mechanical, Aeronautical, Civil and Automobile Engineering, etc., etc. State your particular requirements

One of these qualifications would increase your earning-power. WHICH ONE ?

A.M.I.E.E.

A.M.Brit.I.R.E.

B.Sc.

City and Guilds

A.M.I.Mech.E.

R.T.E.B. Cert.

The Radio and Television Industry is alive with possibilities—especially to the qualified man. Whatever may be your interest in Radio, Television, or allied subjects, you should not miss reading the unique 108-page Handbook “**ENGINEERING OPPORTUNITIES**” which tells you the easiest way to get some valuable letters after your name and describes the widest range of Home Study Courses in all branches of Engineering.

We Guarantee

“NO PASS—NO FEE”



**108
PAGES
Free!**

If you are earning less than £10 per week let “**ENGINEERING OPPORTUNITIES**” show you how to carve out a successful career in your chosen branch of Engineering, irrespective of your age, education or experience. This helpful book tells you everything you want to know to secure your future and describes many chances you are now missing. In your own interest write for your copy of “**ENGINEERING OPPORTUNITIES**” NOW —**FREE** and without obligation.

BRITISH INSTITUTE OF ENGINEERING TECHNOLOGY
127 SHAKESPEARE HOUSE, 17-19 STRATFORD PLACE, LONDON, W.1

Our endeavour
is to stock and supply every
need of the service engineer,
serious home experimenter
and radio laboratory users

AVO

Oscillators
Model 7 and 40 Meters
Resistance and Capacity Bridges
AvoMinors

TAYLOR

Multi-range Meters
Oscilloscopes
Oscillators
Bridges

**MEASURING INSTRUMENTS
(PULLINS)**

Multi-range Meters
Single Range Meters
Bridges

EDDYSTONE

Communication Receivers
Specialized U.H.F. Components
U.H.F. Communication Apparatus

WELWYN

High-stability Carbon Resistors
Wire-wound Resistors, 2 to 100 watts

LONDEX

Aerial Relays
Power Relays

ROTHERMEL

Crystal Microphones
Crystal Pick-ups

MULLARD

Oscilloscopes
Cathode Ray Units
Bridges

PARTRIDGE

High-Fidelity Output Transformers
Mains Transformers

WILKINS & WRIGHT

Moving Coil Pick-ups

CONNOISSEUR

Miniature Moving Iron Pick-ups

FURZEHILL

Oscilloscopes
Beat Frequency Oscillators

Q.C.C.

Frequency Control Crystals
Resonator Crystals
Calibration Crystals

WODEN

Mains Transformers
L.F. Chokes
Audio Transformers

S. G. BROWN

Moving Coil Headphones
Adjustable Reed Microphones
Lightweight Headphones

LEXINGTON Moving Coil Pick-ups

ROLA Loudspeakers

ERIE Resistors

CELESTION Loudspeakers

T.C.C. Capacitors

DUBILIER . . Capacitors

LABGEAR

Transmitting Inductances
Variable TX Condensers
Crystal Calibrators

WEARITE

Ceramic Wave-change Switches
Receiver Inductances

WEBB'S
RADIO

14 SOHO STREET, OXFORD STREET, LONDON, W.1.

Telephone : Gerrard 2089. Hours of Business : 9 a.m. to 5.15 p.m. Sats. 9 a.m. to 1 p.m.

C L I X

R A D I O

A N D T E L E V I S I O N

C O M P O N E N T S

BRITISH MECHANICAL PRODUCTIONS LIMITED

21 BRUTON STREET, LONDON, W.1

TELEGRAMS : "TROLINX, WESDO, LONDON" • TELEPHONE : MAYFAIR 5543

Quality **ACKNOWLEDGED
THROUGHOUT
THE WORLD**



ERIE
Radio & Electronic Components

**RESISTORS · CERAMICONS · HI-K CERAMICONS · POTENTIOMETERS
SUPPRESSORS · VITREOUS ENAMELLED WIRE-WOUND RESISTORS**

Erie Resistor Ltd., The Hyde, London, N.W.9, England

TELEPHONE: COLINDALE 8011-4.

CABLES: RESISTOR · LONDON

Factories: London and Gt. Yarmouth, England; Toronto, Canada; Erie, Pa., U.S.A.

TELCON PRODUCTS

for the Radio Engineer

CABLES An extensive range of TELCON radio frequency cables is available to meet all requirements. In many of these TELCOTHENE insulation is used. This material is the latest development in thermoplastic insulants. It has a dielectric constant of 2.3 and a power factor of not exceeding 0.0003, is chemically inert, unaffected by sunlight, and highly resistant to moisture and dilute acids and alkalis. Double-screened and Anti-microphonic cables are also available.

METALS TELCON METALS are widely used in modern designs of radio components. The advantages of high permeability and low loss are utilised by the employment of MUMETAL, RADIOMETAL and RHOMETAL for transformers, chokes and magnetic shields. TELCUMAN, with its low temperature coefficient, is suitable for precision resistors, and PYROMIC and CALOMIC can be employed where rise of temperature is likely. The age hardening high tensile 'Cu.Be.250' BERYLLIUM COPPER alloy, with its high fatigue resistance is particularly suitable for springs and electrical contacts. TELCOSEAL glass sealing alloys are available for practically all types of glass employed in radio and television, and TELCON BIMETALS are ideal for delay switches and components involving thermostatic action.

Full details furnished on request.



THE TELEGRAPH CONSTRUCTION & MAINTENANCE CO. LTD.

Head Office: 22 OLD BROAD ST., LONDON, E.C.2. Tel: LONDON Wall 3141

Enquiries to: TELCON WORKS, GREENWICH, S.E.10. Tel: GREENWICH 1040

Founded 1864



THE WIRES YOU WANT...

Are those made by the Sterling Cable Co. Ltd. and include a full range of vulcanised rubber and thermo plastic insulated wire cables and flexibles for every radio purpose. H.F. Polythene insulated wires . . . Low loss and Push Back Wires . . . Television Down Leads . . . all Sterling

Products are manufactured from the finest raw materials to B.S. and G.D. specifications.

STERLING
CABLES OF  **QUALITY**

Sterling Cable Co. Ltd., Aldermaston, Berks
Telephone : Reading 1000

KING OF THE SET



MAZDA

RADIO VALVES AND CATHODE RAY TUBES

Virtually Distortionless

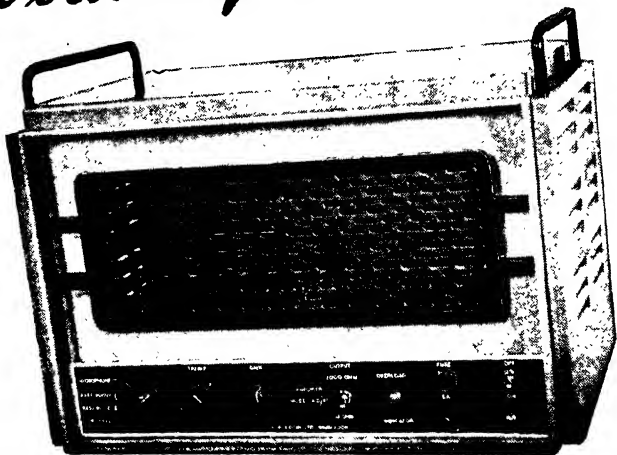

A.D. 47 10-valve Triode Cathode Follower Amplifier

For this recording and play-back amplifier we claim an overall distortion of only 0.01% as measured on a distortion factor meter at middle frequencies for a 10 watt output. The output transformer can be switched from 15 ohms to 2,000 ohms, for recording purposes, the measured damping factor being 40 times in each case. Full details on request.

Vortexion
LTD.

257/261 The BROADWAY
WIMBLEDON, LONDON
S.W.19

Telephones : LI Berty 2814 and 6242/3
Telegrams : "VORTEXION, WIMBLE, LONDON"

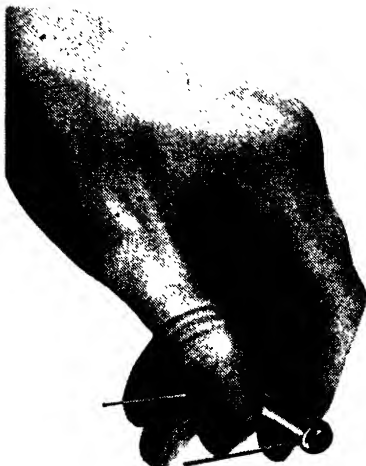

RESISTORS

THE OLD HAND

*whose selection is
guided by knowledge
and experience
always picks out a*



Component



POTENTIOMETERS

SUPPRESSORS



FUSES

for perfect part replacement

RADIO RESISTOR CO. LTD.

QUADRANT WORKS, CUMBERLAND ROAD, STANMORE, MIDDX

Telephone : WORDsworth 1138-9

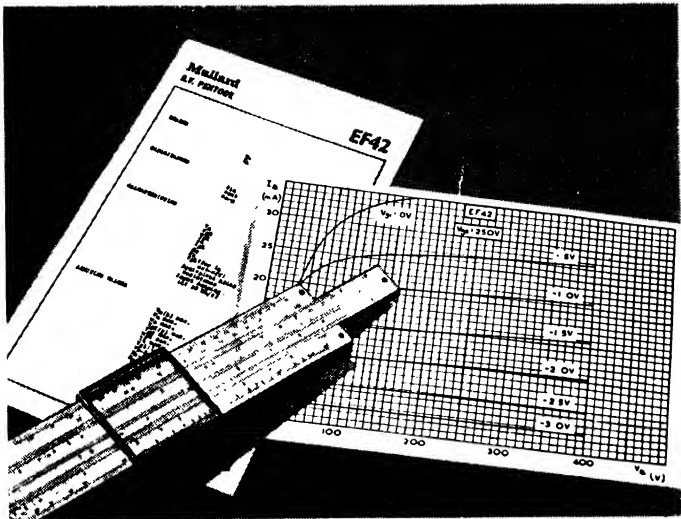

*Somebody is designing
another good circuit*

When you see a circuit using Mullard valves you can be sure it is about the best in its class. Designers who are so wise in their choice of valves seldom err in other directions.

Mullard

THE MASTER VALVE



THE MULLARD WIRELESS SERVICE CO. LTD., CENTURY HOUSE · SHAFESBURY AVENUE · LONDON W.C.2

A LABORATORY INSTRUMENT

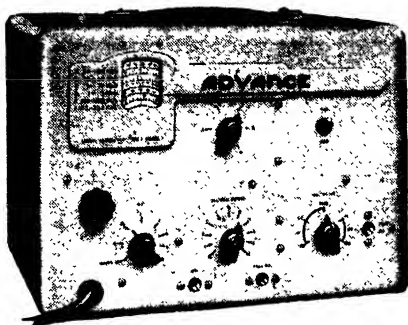

... but NOT
Laboratory
Price!

The

Advance ^{TYPE} Signal Generator

RANGE: 100 Kc/s-60 Mc/s on fundamentals (up to 120 Mc/s on Second Harmonic).

ACCURACY:

Guaranteed within $\pm 1\%$.

ATTENUATION: Constant impedance system embodying a matched 75 ohms transmission line.

STRAY FIELD: Less than 3 microvolts at 60 megacycles.

ILLUMINATED DIAL:
Total scale length 30°.

POWER SUPPLY:
110-210-230-250 volts.

DIMENSIONS:
13" x 10½" x 7½" deep.

WEIGHT: 15 lbs.

THE "Advance" Type 'E' Signal Generator places an instrument of laboratory class within the financial scope of every radio service engineer and experimenter. The discerning engineer will appreciate its accuracy and stability, its **exceptionally wide range** which covers all frequencies required for radio and television receivers, and its accurate attenuating system which enables sensitivity measurements to be made on highly sensitive receivers up to 60 Mc/s.

Send for fully descriptive pamphlet.

ADVANCE COMPONENTS LTD.

BACK ROAD, SHERNHALL STREET, WALTHAMSTOW, LONDON, E.17

Telephone: LARKSWOOD 4366-7-8

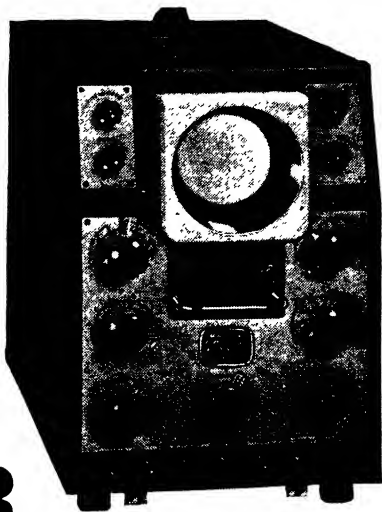

COSSOR

Announce

THE NEW MODEL
1035
 DOUBLE BEAM
 OSCILLOGRAPH

The Model 1035 is a general purpose Oscillograph, consisting of a Double Beam Tube Unit, Time Base, Y Deflection Amplifiers and internal Power Supplies. The two traces are presented over the full area of a flat screen tube of 90 mm. internal diameter and operating at 2kv. Signals are normally fed via the Amplifiers, with provision for input voltage calibration. The Time Base is designed for repetitive, triggered, or single stroke operation, and time measurement is provided by a directly calibrated Shift Control. For photographic recording the Model 1035 has provision for the attachment of a Camera, Model 1428, which may be operated either manually or by motor drive. A similar camera, Model 427, is also available for use with Model 339 Oscillograph.

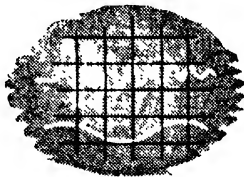

Further details on application to:-

A. C. COSSOR LTD., INSTRUMENT DEPT., Highbury, London, N.5
 CI/80

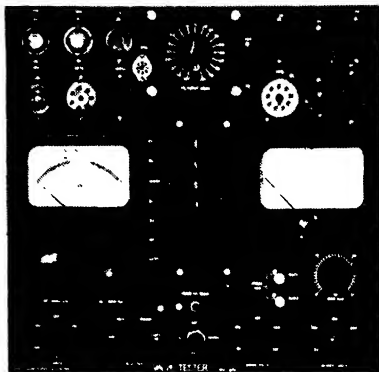

A Valve Tester which is simple to operate yet gives the accuracy of a laboratory instrument

Complete switching of all electrodes is incorporated with interlocked filament switch to prevent short circuit. A differential relay fully protects the instrument. Valves can be tested under conditions specified in the valve manufacturers' lists without reference to charts, etc.

WRITE FOR LEAFLET 217
FOR FULL TECHNICAL DATA

LABORATORY



TESTED

H. C. Atkins Laboratories, Cumberland Road, Kew. RIC. 2950

LABORATORY INSTRUMENTS

FIRST-GRADE MEASURING AND TESTING EQUIPMENT FOR PHYSICAL AND COMMUNICATIONS LABORATORIES

This Company is producing, on a restricted scale, a range of specialised Measuring and Test Equipment of the very highest quality. Special apparatus is also manufactured to customers' specifications. If you are equipping a Laboratory please consult us.

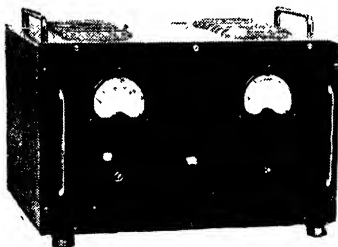

CONSTANT-VOLTAGE POWER SUPPLIES

A range of standard models is available, of various output voltages and current ratings. The output voltage is substantially independent of Mains voltage or load current, within the specified limits. Illustrated is the Model 101-A, which provides an output voltage from 250 to 400 volts at up to 250 mA, with a Stabilisation Ratio greater than 100 and an Internal Resistance less than 1 ohm.

HIGH-VOLTAGE TEST SETS

These equipments are designed for high-voltage insulation tests on all types of components, including capacitors. Tests may be made either with DC or AC. All models include a large scale Electrostatic Voltmeter which is also available, independently, for the measurement of high voltages. Illustrated is the Model 301-A, which covers the range from 1,000 to 5,000 volts.

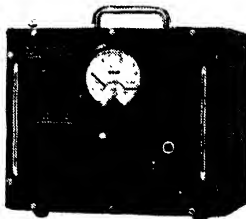

BRIDGES, SIGNAL GENERATORS, OSCILLATORS,
OSCILLOSCOPES. REGULATED POWER SUPPLIES.
PRECISION WOUND TRANSFORMERS & CHOKES

PRECISION, QUALITY AND RELIABILITY

ALL-POWER TRANSFORMERS LTD.

WIMBLEDON, S.W.19

Telephone : LIBerty 3303

PRECISION COMPONENTS



CORD DRIVES

Now available in five types as illustrated (left to right) Standard, R/V, Reverse, "D" type and "A" type. All one hole fixing.

GANG CONDENSERS

A wide range is now available in 1, 2, 3 or 4 gang types of various capacities.

JACKSON

BROS (LONDON) LIMITED

KINGSWAY · WADDON · SURREY

TELEPHONE.
CROYDON 275+5

TELEGRAMS · WALFILCO.
PHONE, LONDON

Write for Catalogue No. (S.M. 1.)

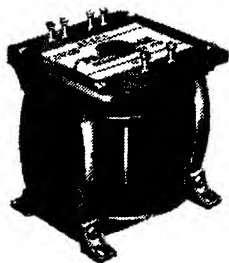
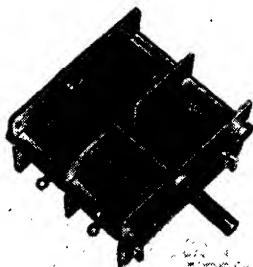

Telephone :

Brixton 6506

PARTRIDGE TRANSFORMERS LTD

12 PECKFORD PLACE, BRIXTON ROAD, S.W.9

PARTRIDGE TRANSFORMERS

for LABORATORY USE
and EXPERIMENTAL
WORK

Specially wound to
customers' requirements.

Prompt Delivery.

As supplied to National
Physical Laboratory,
B.B.C., Post Office,
Government Research Es-
tablishments, etc., and the
author of the "Wireless
Servicing Manual."

Catalogue free on request

New Partridge Manual
5/- post free



Universally useful The human hands are universally useful. With the aid of apparatus designed for a particular job, their adaptability can be infinitely extended. Designed for the systematic analysis of faults on defective radio sets or other electrical equipment, the Weston Model E772 Analyser is universally useful in the hands of an engineer. Its features include high sensitivity—20,000 ohms per volt on all D.C. ranges—wide range coverage, accuracy, robust construction and the quality for which Weston instruments are world famous. Please ask for details.

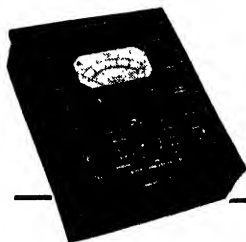

WESTON
E 772 *Analyser*

SANGAMO WESTON LTD., ENFIELD, MIDDX.
Telephone: Enfield 3434 & 1242

Wharfedale

LOUDSPEAKER SEPARATOR

Cross-over at 1,000 c.p.s. MAXIMUM INPUT 30 WATTS at 3 to 15 ohms impedance. A new device for dividing the Bass and Treble between two Loudspeakers at low impedance, thus eliminating modulation distortion imposed on the treble by large coil movement in the bass. It is recommended for use with two speakers of equal sensitivity and similar size.

PRICE 75/-

Size: 8 in. x 5 in. x 4 in.

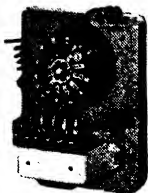

CHOKE-TYPE VOLUME CONTROL

For use on Loudspeakers with Cross-over Units where resistance types are useless, or where distortionless control is essential. Suitable for circuits of 2 to 30 ohms up to 30 watts

PRICE 27/6

WHARFEDALE WIRELESS WORKS

Bradford Rd., Idle, Bradford · Phone: Idle 461 · Grams: "Wharfedel, Idle, Bradford"

The NEW "ACRU 24" ELECTRIC SOLDERING IRON

ELEMENT

Totally enclosed, air-tight, crash-proof and virtually everlasting.

HANDLE

Heat-reflecting, balanced, giving perfect control.

COPPER BITS

Instantly detachable and interchangeable by rotating locking collar. No screws, no tools required.

HEAT REFLECTING COVER

HEAT ALUMINUM COVER

AIR TIGHT SEALS

STEEL TUBE CARRYING THE ELEMENT AND COVERING THE COPPER BIT

CAM FACE TO ENGAGE FIXING COLLAR

HIGHEST QUALITY MICA INSULATION

MICA INSULATED & STEEL COVERED CONNECTING LEADS

TRUMPET SHAPED COOLING REFLECTOR

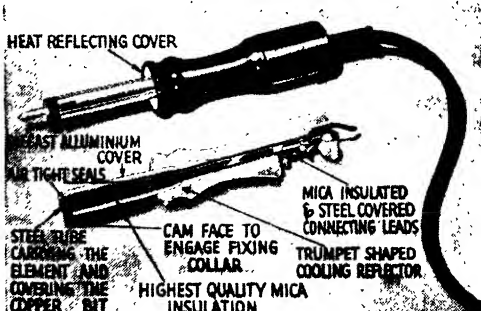

THE INSTRUMENT IRON WITH UNPARALLELED FEATURES

World Patents
Applied for

Write now for illustrated
Leaflet giving full details

THE ACRU ELECTRIC TOOL MFG. Co. Ltd., 123 HYDE RD., MANCHESTER 12



Our experience in the manufacture of Electronic Equipment is extensive, as the following products show

MICROPHONES

Carbon • Moving Coil

WAVEMETERS

Absorption • Heterodyne

TRANSFORMERS • CHOKES

Power • Audio-frequency • Radio-frequency

LOUD SPEAKERS

High-frequency • High-fidelity • Diffuser
Reflector

TRANSMITTERS

Amplitude Modulated • Frequency Modulated

AMPLIFIERS

Audio-frequency • Intermediate-frequency
Wide-band Radio-frequency

ATTENUATORS

**WHITELEY ELECTRICAL RADIO
CO., LTD. MANSFIELD, NOTTS.**

MELTON METALLURGICAL LABORATORIES LTD

Liquid Silver, Platinum and Gold
for metallising CERAMIC,
MICA, QUARTZ or GLASS

Low Melting-point **SOLDER** from 70°C.

Non-corrosive liquid **FLUX** for all electrical purposes.

Agents for Australia :

A. S. HARRISON & CO. PTY. LTD.
85 CLARENCE STREET, SYDNEY

IPSWICH RD., TRADING ESTATE
SLOUGH, BUCKS. Phone: SLOUGH 20992

QUIXO BATTERY TESTER



RAPID. ACCURATE. RELIABLE

The only satisfactory way of testing all accumulators—

ACID, JELLY & DRY TYPES

Tens of thousands already in use
Combined model tests H/T & L/T

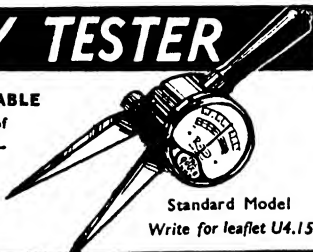

Standard Model
Write for leaflet U4.15

NEW DUAL TESTSCOPE

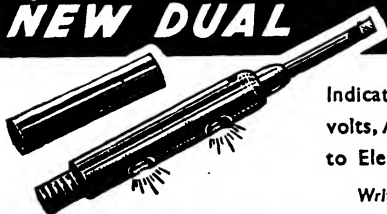

Indicates 2/30 volts and 100/750 volts, A.C. and D.C. Indispensable to Electrical and Radio Engineers

Write for interesting booklet U4.4

RUNBAKEN-MANCHESTER-1

IT COSTS SO LITTLE
—AND MEANS SO MUCH—TO USE

The finest cored solder in the world

FOR RADIO REPAIRS

Ersin Multicore Solder is the only solder in the world containing three cores of extra-active non-corrosive Ersin Flux. The three-core construction of Ersin Multicore ensures flux continuity and the correct proportions of flux to solder, enabling soldering operations to be carried out at high speed and eliminating waste. With the correct soldering technique, Ersin Multicore gives a guaranteed standard of sound precision joints and avoids 'dry' or H.R. joints.



The Handyman
(Size 2) Carton, for
use in the home,
contains enough
solder for 200 aver-
age joints.

Price : 6d.

Prices for Size 1 Cartons.

Catalogue Ref. No.	Alloy Tin-Lead	S.W.G.	Approx. length per carton	List price per carton (sub.)	
				s.	d.
C 16014	60/40	14	38 feet	6	0
C 16018	60/40	18	102 feet	6	9
C 14013	40,60	13	25 feet	4	10
C 14016	40/60	16	53 feet	5	3

Order from your factor, in case of difficulty write to :

MULTICORE SOLDERS LTD.

Mellier House, Albemarle Street, London, W.1
Tel. : REGent 1411

**ENGLISH & AMERICAN
TECHNICAL BOOK
SPECIALISTS**

*We have the Finest Stock of
Radio and Electronic Engineering
Books in the Country*

COMPLETE LIST ON APPLICATION

The
MODERN BOOK CO.
19-23 PRAED STREET
LONDON, W.2
Telephone : PAD. 4185

YOU
can become a first-class
RADIO ENGINEER

The real Service Engineer does not rely on guesswork or luck. In order to tackle every job efficiently, confidently and quickly, he knows that he must have a thorough knowledge of modern circuits.

We specialise in teaching radio and allied subjects. Our method of Home-Study Tuition is an outstanding success. Hundreds of students owe their progress and improved earnings solely to our training.

We invite you to write for free details of our Home-Study Courses in Radio Reception, Servicing, Transmission, Television, Radio Calculations and Mathematics. (*Please quote ref. : WSM6*).

T. & C. RADIO COLLEGE
King Edward Ave., Aylesbury, Bucks

PREMIER RADIO CO

MORRIS & CO. (RADIO) LTD.

All Post Orders to :

167 LOWER CLAPTON ROAD, LONDON, E.5

Phone: Amherst 4723

Callers to :

169 FLEET STREET, LONDON, E.C.4

Phone: Central 2833

Our Comprehensive Price List is a necessity to everyone engaged in the Radio Industry. It contains hundreds of items available from Stock. Price 2½d., post paid.

ELECTROLYTIC CONDENSERS.

Capacity	Working Voltage	Type Container	Fitting	Dimensions	Price
8mf	500	Ali Tube	Clip	2" × 1"	3/-
8 × 8mf	500	Cardboard Tube	Clip	2" × 1½"	7/6
16 × 8mf	450	Ali Tube	Clip	4½" × 1½"	6/6
16 × 8mf	350	Ali Tube	Clip	2" × 1½"	6/6
40mf	200	Ali Tube	Clip	2½" × 1½"	5/-
50mf	12	Cardboard Tube	Wire End	1½" × ½"	1/6
25mf	25	Cardboard Tube	Wire End	1½" × ½"	1/6
12mf	100	Cardboard Tube	Wire End	1½" × ½"	1/6
50mf	50	Cardboard Tube	Clip	3½" × 1½"	3/-
250mf	12	Metal Tube	Nil	2½" × 1"	2/6
4mf	12	Cardboard Tube	Wire End	1½" × ½"	1/-
50mf	50	Ali Tube	Bolt	2" × ½"	2/-
16 × 16mf	...	Cardboard Tube	Clip	3½" × 1½"	7/6
32mf	350	Ali Tube	Clip		3/11

FIRST GRADE OIL FILLED PAPER CONDENSERS, with miniature stand-off insulators and fixing clips, 2 mfd. 1,000 v.w., 2/6 or 20/- per dozen; 2 mfd. 600 v.w., 1/9 each or 14/- per dozen; 1 mfd. 600 v.w., 1/3 each or 12/- per dozen. Super Quality Oil Filled Tubulars. Insulation as good as Mica; 1 mfd. 500 v.w., .5 mfd. 350 v.w. Either type, 9d. each, or 7/6 per dozen.

We can offer from large stocks **TUBULAR, MOULDED MICA, SILVER MICA** and **CERAMIC CONDENSERS** in all capacities. Special price per dozen 4/6, per gross 50/- assorted.

Serviceimen's Parcels of **POTENTIOMETERS**, 12 assorted sizes suitable for replacements. 10/6 Carbon. 12/- Wire Wound.

ALUMINIUM CHASSIS. Substantially made of bright aluminium, with four sides. 10in. × 8in. × 2½in., 7/-; 12in. × 9in. × 2½in., 7/9; 16in. × 8in. × 2½in., 8/6; 20in. × 8in. × 2½in., 10/6; 22in. × 10in. × 2½in., 13/6.

BUILD YOURSELF AN OSCILLOSCOPE. Test Unit Type 73—consists of a special-purpose Oscilloscope that requires only rewiring and the addition of a few Condensers and Resistors to convert into a standard Oscilloscope, input 230v., 50c. A 3½" C.R. Tube and 1 S.U.220A, 1 E.B.34, 1 5Z4, 3 S.P.41, 2 A.E.50, are included. Controls are " Brightness ", " Velocity ", " X Shift ", " Y Shift ", Focus Amplifier "in/out", " Calibrate ", " on/off/TX ". Price £8/8/0d. Carriage and packing, 20/- . Complete with Metal Case.

MIDGET T.R.F. RADIO KIT. Build your own Receiver. All parts, including Valves, Speaker and instructions. Nothing else to buy, 4-valve, wavebands 200-557m. and 700-2,000 metres, 200-250v. A.C./D.C. mains, or A.C. only. Please state which is required. Size 10in. × 6in. × 6in. £8/0/11d. including tax.

MIDGET SUPERHET RADIO KIT. All parts, including Valves, Speaker and instructions, to build a 5-valve Superhet. 16-50m. and 200-257 metres, 200-250v. A.C./D.C. or A.C. only. Please state which is required. Size 10in. × 6in. × 6in. Price £9, including tax. An attractive brown bakelite cabinet can be supplied for either Kit at 27/3.

What's new in Radio, Television and Electronics?

THESE AUTHORITATIVE JOURNALS
WILL GIVE YOU THE ANSWER

Wireless World The Journal for Manufacturers, Designers and Technicians

"Wireless World" is Britain's leading technical magazine in the general field of radio, television and electronics. It provides a complete and accurate survey of the newest technique in design and manufacture and covers every phase of the radio and allied industries, with reviews of equipment, broadcast receivers and components.

MONTHLY 1/6

ANNUAL SUBSCRIPTION 20/-

WIRELESS ENGINEER The Journal of Radio Research and Progress for Engineers and Physicists

"Wireless Engineer" is read by research engineers, designers and students, and is accepted internationally as a source of information for advanced workers; only original work is published. Regular features include British patent specifications and abstracts and references compiled by the Radio Research Board.

MONTHLY 2/6

ANNUAL SUBSCRIPTION £1.12.6



ILIFFE & SONS LIMITED
Dorset House, Stamford St., London, S.E.1

WHERE EXTREME ACCURACY IS REQUIRED



Bullers

CAN SATISFY THE MOST EXACTING CUSTOMER

Made in Three
Principal Materials

FREQUELEX

An insulating material of Low Di-electric Loss, for Coil Formers, Aerial Insulators, Valve Holders, etc.

PERMALEX

A High Permittivity Material. For the construction of Condensers of the smallest possible dimensions.

TEMPLEX

A Condenser material of medium permittivity. For the construction of Condensers having a constant capacity of all temperatures.



BULLERS LOW LOSS CERAMICS

BULLERS LTD., 6 Laurence Pountney Hill, London, E.C.4
Phone: Mansion House 9971 (3 lines). Telegrams: "Bullers, Cannon, London."



The books listed below are selected from the extensive range published in association with the 31 Technical, Trade and Specialised journals of Associated Iilffe Press. New titles are added and revised editions issued to ensure that the information is complete, accurate and up-to-date.

RADIO

BASIC MATHEMATICS FOR RADIO STUDENTS

By F. M. Colebrook, B.Sc., D.I.C., A.C.G.I.
10s. 6d. By post 10s. 10d.

FOUNDATIONS OF WIRELESS

(4th Edition, Revised)
By M. G. Scroggie, B.Sc., M.I.E.E.
7s. 6d. By post 7s. 10d.

RADIO LABORATORY HANDBOOK

(4th Edition)
By M. G. Scroggie, B.Sc., M.I.E.E.
12s. 6d. By post 12s. 10d.

TELEVISION RECEIVING EQUIPMENT

(2nd Edition)
By W. T. Cocking, M.I.E.E.
12s. 6d. By post 12s. 11d.

MOTORING

KNOW YOUR CAR (3rd Edition)

2s. 6d. By post 2s. 8d.

LOOK AFTER YOUR CAR: Everyday Maintenance Simply Explained (2nd Edition)

3s. 6d. By post 3s. 10d.

"THE AUTOCAR" HANDBOOK

(20th Edition)
5s. 0d. By post 5s. 4d.

MOTOR CYCLING

MOTOR CYCLES AND HOW TO MANAGE THEM (31st Edition)

4s. 6d. By post 4s. 10d.

SPEED FROM YOUR MOTOR CYCLE (6th Edition)

3s. 6d. By post 3s. 10d.

TWO-STROKE MOTOR CYCLES

(10th Edition)
3s. 0d. By post 3s. 3d.

MOTOR CYCLIST'S WORKSHOP

(5th Edition)
By "Torrens" of "The MotorCycle"
3s. 0d. By post 3s. 3d.

PHOTOGRAPHY

BRIGHTER PHOTOGRAPHY (3rd Edition)

By David Charles, F.R.P.S.
4s. 6d. By post 4s

PHOTOGRAPHIC ENLARGING (2nd Edition)

By David Charles, F.R.P.S.
4s. 6d. By post 4-

PHOTOGRAPHIC SKIES

By David Charles, F.R.P.S.
5s. 0d. By post 5s.

DICTIONARY OF PHOTOGRAPHY (17th Edition)

15s. 0d. By post 15s.

ARCHITECTURE

PLANNING: The Architect's Handbo

(5th Edition)
21s. 0d. By post 21s. 8d.

ROAD TRANSPORT

DIESEL MAINTENANCE (2nd Edit.

By T. H. Parkinson, M.I.Mech.
Edited by Donald H. Smith, M.I.
Mech.E., Assoc.Inst.T.
6s. 0d. By post 6s. 4d.

AUTOMOBILE CHASSIS DESIGN

By R. Dean Averns.
15s. 0d. By post 15s. 8-

MODERN DIESEL (11th Edition , preparation)

Edited by G. Geoffrey Smith, M.B.E.
Revised by Donald H. Smith, M.I.
Mech.E., Assoc.Inst.T.

YACHTING

YACHT RACING: A Textbook of th Sport

By B. Heckstall-Smith. Revised and enlarged by G. Sambrooke Sturgess
25s. 0d. By post 25s. 8d

Obtainable of all booksellers or direct from: THE PUBLISHING DEPT.,

DORSET HOUSE, STAMFORD STREET, LONDON, S.E.1, ENGLAND

